

# Hitachi Storage Navigator Modular 2

## Hitachi Storage Navigator Modular 2 User's Guide

### FASTFIND LINKS

- Document organization
- Related documents
- Getting help
- Contents

Copyright © 2010 Hitachi Ltd., Hitachi Data Systems Corporation, ALL RIGHTS RESERVED

No part of this publication may be reproduced or transmitted in any form or by any means, electronic or mechanical, including photocopying and recording, or stored in a database or retrieval system for any purpose without the express written permission of Hitachi, Ltd. and Hitachi Data Systems Corporation (hereinafter referred to as "Hitachi").

Hitachi, Ltd. and Hitachi Data Systems reserve the right to make changes to this document at any time without notice and assume no responsibility for its use. Hitachi, Ltd. and Hitachi Data Systems products and services can only be ordered under the terms and conditions of Hitachi Data Systems' applicable agreements.

All of the features described in this document may not be currently available. Refer to the most recent product announcement or contact your local Hitachi Data Systems sales office for information on feature and product availability.

**Notice:** Hitachi Data Systems products and services can be ordered only under the terms and conditions of Hitachi Data Systems' applicable agreement(s). The use of Hitachi Data Systems products is governed by the terms of your agreement(s) with Hitachi Data Systems.

Hitachi is a registered trademark of Hitachi, Ltd. in the United States and other countries. Hitachi Data Systems is a registered trademark and service mark of Hitachi in the United States and other countries.

All other trademarks, service marks, and company names are properties of their respective owners.



# Contents

1	Introduction . . . . .	1-1
	Navigator 2 at a glance . . . . .	1-2
	Key features . . . . .	1-2
	Integrating with Hitachi storage features . . . . .	1-3
	What this document covers . . . . .	1-4
	Using the Navigator 2 online help . . . . .	1-5
2	Preinstallation Information . . . . .	2-1
	Understanding Navigator 2 key terms . . . . .	2-2
	Quick-start checklist. . . . .	2-3
	Navigator 2 operating environment . . . . .	2-3
	Microsoft Windows operating systems . . . . .	2-4
	Sun Solaris operating systems. . . . .	2-5
	Red Hat Linux operating systems . . . . .	2-5
	Network requirements . . . . .	2-6
	Collecting user-supplied items. . . . .	2-7
	Installing Java runtime. . . . .	2-7
	Downloading and installing JRE. . . . .	2-7
	Clients running Microsoft Windows . . . . .	2-7
	Clients running Solaris or Linux . . . . .	2-9
	Firewall considerations. . . . .	2-9
	Anti-virus software considerations. . . . .	2-9
	Obtaining license keys . . . . .	2-10
	Reviewing technical guidelines . . . . .	2-10
	Windows operating systems . . . . .	2-10
	Installation prerequisites . . . . .	2-10
	Selecting a destination folder . . . . .	2-10
	Solaris and Linux operating systems . . . . .	2-11
	Installation prerequisites . . . . .	2-11
	Setting Linux kernel parameters . . . . .	2-11
	Hitachi Storage Command Suite common component considerations . . . . .	2-14

3	Installing Navigator 2 . . . . .	3-1
	Types of installations . . . . .	3-2
	Installing Navigator 2 . . . . .	3-2
	Getting started (all users) . . . . .	3-2
	Installing Navigator 2 on a Windows operating system . . . . .	3-3
	If the installation fails on a Windows operating system . . . . .	3-8
	Installing Navigator 2 on a Sun Solaris operating system . . . . .	3-10
	Installing Navigator 2 on a Red Hat Linux operating system . . . . .	3-11
	. . . . .	3-12
4	Starting Navigator 2 . . . . .	4-1
	Hardware considerations . . . . .	4-2
	Verifying your hardware installation . . . . .	4-2
	Connecting the management console . . . . .	4-2
	Logging in to Navigator 2 . . . . .	4-2
	Selecting a storage system for the first time . . . . .	4-4
	Running the Add Array wizard . . . . .	4-5
	Running the Initial (Array) Setup wizard . . . . .	4-7
	Initial Array (Setup) wizard — configuring email alerts . . . . .	4-8
	Initial Array (Setup) wizard — configuring management ports . . . . .	4-9
	Initial Array (Setup) wizard — configuring host ports . . . . .	4-10
	Initial Array (Setup) wizard — configuring spare drives . . . . .	4-13
	Initial Array (Setup) wizard — configuring the system date and time . . . . .	4-13
	Initial Array (Setup) wizard — confirming your settings . . . . .	4-13
	Running the Create & Map Volume wizard . . . . .	4-14
	Create & Map Volume wizard — defining RAID groups . . . . .	4-14
	Create & Map Volume wizard — defining logical units . . . . .	4-16
	Create & Map Volume wizard — defining host groups or iSCSI targets . . . . .	4-17
	Create & Map Volume wizard — connecting to a host . . . . .	4-18
	Create & Map Volume wizard — confirming your settings . . . . .	4-19
	Running the backup volume wizard . . . . .	4-19
5	Quick Tour . . . . .	5-1
	Understanding the Navigator 2 interface . . . . .	5-2
	Menu Panel . . . . .	5-2
	Explorer Panel . . . . .	5-2
	Button panel . . . . .	5-3
	Page panel . . . . .	5-3
	Performing Navigator 2 activities . . . . .	5-3
	Description of Navigator 2 activities . . . . .	5-5
6	Managing Users, Permissions, and Passwords . . . . .	6-1
	Managing users . . . . .	6-2

Adding users . . . . .	6-2
Viewing and editing user profiles . . . . .	6-3
Deleting users . . . . .	6-3
Understanding permissions . . . . .	6-4
Granting or changing permissions . . . . .	6-5
Changing passwords . . . . .	6-6
Changing the default system password . . . . .	6-6
Changing a user password . . . . .	6-6
Password protection . . . . .	6-7
Accessing password protection . . . . .	6-7
Changing a password associated with password protection . . . . .	6-8
Working with user IDs . . . . .	6-8
Adding a user ID . . . . .	6-8
Changing a user ID . . . . .	6-8
Deleting a user ID . . . . .	6-9
<b>7 Managing Storage Systems . . . . .</b>	<b>7-1</b>
Understanding the Arrays window . . . . .	7-2
Rebooting storage systems . . . . .	7-3
Showing and configuring storage systems . . . . .	7-4
Editing storage system settings . . . . .	7-5
Filtering storage systems . . . . .	7-7
Removing storage systems . . . . .	7-8
Running error monitoring . . . . .	7-8
Configuring error monitoring options . . . . .	7-10
Configuring email notifications . . . . .	7-11
Running error monitoring . . . . .	7-11
Error messages . . . . .	7-12
Managing alerts and events . . . . .	7-13
<b>8 Managing RAID Groups . . . . .</b>	<b>8-1</b>
Overview . . . . .	8-2
Displaying the RAID Groups tab . . . . .	8-2
Creating a RAID group . . . . .	8-3
Expanding RAID groups . . . . .	8-5
General guidelines . . . . .	8-5
RAID group expansion best practices . . . . .	8-6
Expanding RAID groups . . . . .	8-7
Removing RAID group expansion . . . . .	8-8
Displaying detailed RAID group properties . . . . .	8-9
Understanding the Logical Units tab . . . . .	8-10
Understanding the Assigned Drives tab . . . . .	8-10
Executing a RAID group spin-up or spin-down . . . . .	8-12
Changing RAID group expansion priority . . . . .	8-13
Filtering RAID groups . . . . .	8-14

Deleting RAID groups . . . . .	8-15
<b>9 Managing Logical Units . . . . .</b>	<b>9-1</b>
Overview . . . . .	9-2
Identifying logical units . . . . .	9-2
Types of logical units . . . . .	9-2
Understanding preconfigured logical units . . . . .	9-2
Displaying the Logical Units window . . . . .	9-3
Creating a logical unit . . . . .	9-4
Changing LUN capacity . . . . .	9-6
Guidelines when expanding logical units . . . . .	9-6
Expanding logical units. . . . .	9-6
Reducing logical units . . . . .	9-7
Changing the capacity of a logical unit. . . . .	9-7
Displaying unified logical unit properties . . . . .	9-11
Formatting logical units . . . . .	9-11
Filtering logical units . . . . .	9-12
Deleting logical units . . . . .	9-13
<b>10 Advanced Functions . . . . .</b>	<b>10-1</b>
Using Internet Protocol Version 6 . . . . .	10-2
IPv6 guidelines . . . . .	10-2
Navigator 2 supported operating systems for IPv6 . . . . .	10-2
IPv6 link-local addresses . . . . .	10-2
Router discovery . . . . .	10-4
Temporary addresses. . . . .	10-5
Connection methods . . . . .	10-5
Example 1 . . . . .	10-5
Example 2 . . . . .	10-6
Using secure sockets layer . . . . .	10-7
Setting the certificate and private key . . . . .	10-8
Stopping the Navigator 2 service or daemon process . . . . .	10-8
Creating a private key . . . . .	10-8
Changing the IP Address for connecting to Navigator 2. . . . .	10-13
Changing the Default Port Number for Navigator 2 . . . . .	10-14
Starting or stopping the Navigator 2 service or daemon process . . . . .	10-15
Stopping the services or daemon processes . . . . .	10-15
Stopping the Navigator 2 server service or daemon process . . . . .	10-16
Windows operating systems . . . . .	10-16
Solaris and Linux operating systems . . . . .	10-16
Stopping Hitachi Storage Command Suite common components . . . . .	10-17
Windows operating systems . . . . .	10-17
Solaris and Linux operating systems . . . . .	10-17
Starting the services or daemon process . . . . .	10-18

Starting the Hitachi Storage Command Suite common components . . . . .	10-19
Windows operating systems . . . . .	10-19
Solaris and Linux operating systems . . . . .	10-19
Starting the Navigator 2 server service or daemon process . . . . .	10-20
Windows operating systems . . . . .	10-20
Solaris and Linux operating systems . . . . .	10-21
Using the SATA Write and Compare feature . . . . .	10-21
User Account settings for HiCommand Device Manager and Navigator 2 . . . .	10-22
Overview . . . . .	10-22
Example of using the different account types . . . . .	10-24
11 Troubleshooting . . . . .	11-1
If the Installation Fails on a Windows Operating System . . . . .	11-2
Collecting Trace Information . . . . .	11-3
Firmware Troubleshooting . . . . .	11-4
DMES01EA05 Message Appears During Firmware Upgrade . . . . .	11-4
Upgrading Firmware When the Storage System Has a Warning Status . . .	11-5
List of Failure Codes . . . . .	11-7
. . . . .	11-8
A Upgrading Navigator 2 . . . . .	A-1
Before you start . . . . .	A-2
Upgrading Navigator 2 on Windows operating systems . . . . .	A-5
Upgrading Navigator 2 on Solaris operating systems . . . . .	A-7
Upgrading Navigator 2 on Linux operating systems . . . . .	A-8
B Uninstalling Navigator 2 . . . . .	B-1
Before you start . . . . .	B-2
Windows operating systems . . . . .	B-2
Solaris and Linux operating systems . . . . .	B-5
C Recording Navigator 2 Settings . . . . .	C-1
D Understanding IP addresses . . . . .	D-1
Working with IP address settings . . . . .	D-2
Viewing your PC's IP address settings . . . . .	D-2
Changing your PC's IP address settings . . . . .	D-3
Internet Protocol version 6 . . . . .	D-4
IPv6 guidelines . . . . .	D-4
Hitachi Storage Navigator Modular 2 graphical interface . . . . .	D-5
IPv6 link-local addresses . . . . .	D-5
Router discovery . . . . .	D-7

Temporary addresses. . . . .	D-7
Connection methods . . . . .	D-8
Example 1 . . . . .	D-8
Example 2 . . . . .	D-9



# Preface

This document provides facilities requirements for preparing and installing Hitachi Adaptable Modular Storage (AMS) 2100, 2300, and 2500, and SMS 100 storage systems. In this document, the AMS storage systems are referred to collectively as the Hitachi AMS 2000 Family storage systems. If information pertains to certain members of this family, those systems are identified.

Using this document, you will be able to prepare your site for the arrival and installation of your units. To determine the total components your shipment will include, please consult your Hitachi Data Systems representative.

This preface includes the following information:

- [Document revision level](#)
- [Changes in this revision](#)
- [Intended audience](#)
- [Document organization](#)
- [Document conventions](#)
- [Related documents](#)
- [Regulatory information](#)
- [Getting help](#)
- [Comments](#)

**Notice:** The use of the Hitachi AMS 2000 Family storage systems and all Hitachi Data Systems products is governed by the terms of your agreement(s) with Hitachi Data Systems.

## Document revision level

This section provides a history of the revision changes to this document.

Revision	Date	Description
MK-99DF8208-00	January 2010	Initial Release
MK-99DF8208-01	April 2010	Revision \$1, supersedes and replaces MK-99DF820, -0\$

## Changes in this revision

- Added appendix on IP Addresses, [Appendix D, Understanding IP addresses](#).

## Intended audience

This document is intended for personnel who will schedule, manage, and perform the tasks required to prepare your site for installing a Hitachi AMS 2000 Family storage systems.

## Document organization

The following table provides an overview of the contents and organization of this document. Click the [chapter title](#) in the first column to go to that chapter. The first page of every chapter or appendix contains a brief list of the contents of that section of the manual, with links to the pages where the information is located.









Chapter/Appendix Title	Description
<a href="#">Chapter 1, Introduction</a>	Provides an overview of Navigator 2, its features, and how it integrates with other Storage Feature applications from Hitachi Data systems.
<a href="#">Chapter 2, Preinstallation Information</a>	Contains information to know before installing Navigator 2, such as the Navigator 2 operating environment and items to have ready before installation. This chapter also covers technical information, such as how to use Navigator 2 with firewalls and anti-virus software.
<a href="#">Chapter 3, Installing Navigator 2</a>	Provides step-by-step instructions for installing Navigator 2.
<a href="#">Chapter 4, Starting Navigator 2</a>	Describes how to start Navigator 2 and complete the set up wizards that automatically launch the first time you select a Hitachi storage system in Navigator 2.
<a href="#">Chapter 5, Quick Tour</a>	Takes you on a guided tour of the Navigator 2 interface.
<a href="#">Chapter 6, Managing Users, Permissions, and Passwords</a>	Describes setting up access privileges for Navigator 2 users.
<a href="#">Chapter 7, Managing Storage Systems</a>	Describes concepts and basic configuration of storage systems.
<a href="#">Chapter 8, Managing RAID Groups</a>	Describes concepts and basic configuration of RAID groups.
<a href="#">Chapter 9, Managing Logical Units</a>	Describes concepts and basic configuration of logical units.
<a href="#">Chapter 10, Advanced Functions</a>	Describes Internet Protocol Version 6 and how to use SSL, change the Navigator 2 default port number, start or stop the Navigator 2 service or daemon process and
<a href="#">Appendix A, Upgrading Navigator 2</a>	Describes how to upgrade to a newer version of Navigator 2.
<a href="#">Appendix B, Uninstalling Navigator 2</a>	Describes how to uninstall the Navigator 2 software from a management console.
<a href="#">Appendix C, Recording Navigator 2 Settings</a>	Lets you record your Navigator 2 configuration settings for future reference.
<a href="#">Appendix D, Understanding IP addresses</a>	Describes concepts involved in working with IP addresses.
<a href="#">Glossary</a>	Provides a list of terms related to features and technology associated with Hitachi storage systems and Navigator 2.
<a href="#">Index</a>	The index provides a detailed and linked list of topics in this manual.

## Document conventions

This document uses the following conventions to draw your attention to certain information.

## Safety and warnings

The following symbols are used to draw your attention to certain information.

Symbol	Meaning	Description
	Tip	Tips provide helpful information, guidelines, or suggestions for performing tasks more effectively.
	Note	Notes emphasize or supplement important points of the main text.
	Caution	Cautions indicate that failure to take a specified action could result in damage to the software or hardware.
	WARNING	Warnings indicate that failure to take a specified action could result in loss of data or serious damage to hardware.
	DANGER	Danger warns users of possible injury or death if instructions are not followed.
	ELECTRIC SHOCK HAZARD!	This symbol warns users of electric shock hazard. Failure to take appropriate precautions such as not opening or touching hazardous areas of the equipment could result in injury or death.
	Electrostatic Sensitive	The ESD symbol warns users that the equipment is sensitive to electrostatic discharge (ESD) and could be damaged if users do not take appropriate precautions such as using a grounded wrist strap when touching or handling the equipment.
	Sharp Edges or corners	This symbol warns that the equipment may have sharp edges or corners. Avoid touching. Also, you may want to wear gloves.

## Typographic conventions

The following typographic conventions are used in this document.

Convention	Description
Bold	Indicates text on a window, other than the window title, including menus, menu options, buttons, fields, and labels. Example: Click <b>OK</b> .
Italic	Indicates a variable, which is a placeholder for actual text provided by the user or system. Example: <i>copy source-file target-file</i> . <b>Note:</b> Angled brackets (< >) are also used to indicate variables.
screen/code	Indicates text that is displayed on screen or entered by the user. Example: # <code>pairdisplay -g oradb</code>

Convention	Description
< > angled brackets	Indicates a variable, which is a placeholder for actual text provided by the user or system. Example: # $\text{pairdisplay -g <group>}$ <b>Note:</b> Italic font is also used to indicate variables.
[ ] square brackets	Indicates optional values. Example: [ a   b ] indicates that you can choose a, b, or nothing.
{ } braces	Indicates required or expected values. Example: { a   b } indicates that you must choose either a or b.
vertical bar	Indicates that you have a choice between two or more options or arguments. Examples: [ a   b ] indicates that you can choose a, b, or nothing. { a   b } indicates that you must choose either a or b.
underline	Indicates the default value. Example: [ <u>a</u>   b ]

## Convention for storage capacity values

Storage capacity values for Hitachi Data Systems' AMS 2100, 2300, and 2500 storage products are calculated based on the following values.

Hard Disk Drives	Logical Units
1 KB = 1,000 bytes	1 KB (kilobyte) = 1,024 bytes
1 MB = 1,000 <sup>2</sup> bytes	1 MB (megabyte) = 1,024 <sup>2</sup> bytes
1 GB = 1,000 <sup>3</sup> bytes	1 GB (gigabyte) = 1,024 <sup>3</sup> bytes
1 TB = 1,000 <sup>4</sup> bytes	1 TB (terabyte) = 1,024 <sup>4</sup> bytes

For further information on Hitachi Data Systems products and services, please contact your Hitachi Data Systems account team, or visit Hitachi Data Systems online at <http://www.hds.com>.

## Related documents

Hitachi Data Systems offers a complete library of user and online documentation to ensure you get the most out of the Hitachi AMS 2000 Family storage systems.

The entire documentation set for the Hitachi AMS 2000 Family storage systems can be accessed on the documentation CD supplied with your storage system and through downloads from the Hitachi Web Portal at:

<http://support.hds.com>

This documentation set consists of the following documents:

### Release notes

- Hitachi Adaptable Modular Storage System Release Notes
- Hitachi Storage Navigator Modular 2 Release Notes




---

Please read the release notes before installing and/or using this product. They may contain requirements and/or restrictions not fully described in this document, along with updates and/or corrections to this document.

---

### Installation and getting started

The following documents provide instructions for installing an AMS 2000 Family storage system. They include rack information, safety information, site-preparation instructions, getting-started guides for experienced users, and host connectivity information. The symbol  identifies documents that contain initial configuration information about Hitachi AMS 2000 Family storage systems.

 **Hitachi AMS2100/2300 Getting Started Guide** (MK-98DF8152)

Provides quick-start instructions for getting an AMS 2100 or AMS 2300 storage system up and running as quickly as possible.

 **Hitachi AMS2500 Getting Started Guide** (MK-97DF8032)

Provides quick-start instructions for getting an AMS 2500 storage system up and running as quickly as possible.

**Hitachi AMS 2000 Family Site Preparation Guide** (MK-98DF8149)

Contains initial site planning and pre-installation information for AMS 2000 Family storage systems, expansion units, and high-density expansion units. This document also covers safety precautions, rack information, and product specifications.

**Hitachi AMS 2000 Family Fibre Channel Host Installation Guide**  
(MK-08DF8189)

Describes how to prepare Hitachi [AMS 2000 Family](#) Fibre Channel storage systems for use with host servers running supported operating systems.

**Hitachi AMS 2000 Family iSCSI Host Installation Guide**  
(MK-08DF8188)

Describes how to prepare Hitachi [AMS 2000 Family](#) iSCSI storage systems for use with host servers running supported operating systems.

## **Storage and replication features**

The following documents describe how to use Storage Navigator Modular 2 (Navigator 2) to perform storage and replication activities.

**Hitachi Storage Navigator 2 Advanced Settings User's Guide**  
(MK-97DF8039)

Contains advanced information about launching and using Navigator 2 in various operating systems, IP addresses and port numbers, server certificates and private keys, boot and restore options, outputting configuration information to a file, and collecting diagnostic information.

**Hitachi Storage Navigator Modular 2 User's Guide** (MK-99DF8208) — this document

Describes how to use Navigator 2 to configure and manage storage on an AMS 2000 Family storage system.

**Hitachi AMS 2000 Family Dynamic Provisioning Configuration Guide**  
(MK-09DF8201)

Describes how to use virtual storage capabilities to simplify storage additions and administration.

**Hitachi Storage Navigator 2 Storage Features Reference Guide for AMS** (MK-97DF8148)

Contains concepts, preparation, and specifications for Account Authentication, Audit Logging, Cache Partition Manager, Cache Residency Manager, Data Retention Utility, LUN Manager, Performance Monitor, SNMP Agent, and Modular Volume Migration.

**Hitachi AMS 2000 Family Copy-on-write SnapShot User Guide**  
(MK-97DF8124)

Describes how to create point-in-time copies of data volumes in AMS 2100, AMS 2300, and AMS 2500 storage systems, without impacting host service and performance levels. Snapshot copies are fully read/write compatible with other hosts and can be used for rapid data restores, application testing and development, data mining and warehousing, and nondisruptive backup and maintenance procedures.

**Hitachi AMS 2000 Family ShadowImage In-system Replication User Guide** (MK-97DF8129)

Describes how to perform high-speed nondisruptive local mirroring to create a copy of mission-critical data in AMS 2100, AMS 2300, and AMS 2500 storage systems. ShadowImage keeps data RAID-protected and fully recoverable, without affecting service or performance levels. Replicated data volumes can be split from host applications and used for system backups, application testing, and data mining applications while business continues to operate at full capacity.

**Hitachi AMS 2000 Family TrueCopy Remote Replication User Guide**  
(MK-97DF8052)

Describes how to create and maintain multiple duplicate copies of user data across multiple AMS 2000 Family storage systems to enhance your disaster recovery strategy.

**Hitachi AMS 2000 Family TrueCopy Extended Distance User Guide**  
(MK-97DF8054)

Describes how to perform bi-directional remote data protection that copies data over any distance without interrupting applications, and provides failover and recovery capabilities.


## **Hitachi AMS 2000 Data Retention Utility User's Guide (MK-97DF8019)**

Describes how to lock disk volumes as read-only for a certain period of time to ensure authorized-only access and facilitate immutable, tamper-proof record retention for storage-compliant environments. After data is written, it can be retrieved and read only by authorized applications or users, and cannot be changed or deleted during the specified retention period.

## **Hitachi Storage Navigator Modular 2 online help**

Provides topic and context-sensitive help information accessed through the Navigator 2 software.

## **Hardware maintenance and operation**

The following documents describe how to operate, maintain, and administer an AMS 2000 Family storage system. They also provide a wide range of technical information and specifications for the AMS 2000 Family storage systems. The symbol  identifies documents that contain initial configuration information about Hitachi AMS 2000 Family storage systems.

### **Hitachi AMS 2100/2300 Storage System Hardware Guide (MK-97DF8010)**

Provides detailed information about installing, configuring, and maintaining AMS 2100 and 2300 storage systems.

### **Hitachi AMS 2500 Storage System Hardware Guide (MK-97DF8007)**

Provides detailed information about installing, configuring, and maintaining an AMS 2500 storage system.

### **Hitachi AMS 2000 Family Storage System Reference Guide (MK-97DF8008)**

Contains specifications and technical information about power cables, system parameters, interfaces, logical blocks, RAID levels and configurations, and regulatory information about AMS 2100, AMS 2300, and AMS 2500 storage systems. This document also contains remote adapter specifications and regulatory information.

## **Hitachi AMS 2000 Family Storage System Service and Upgrade Guide (MK-97DF8009)**

Provides information about servicing and upgrading AMS 2100, AMS 2300, and AMS 2500 storage systems.

## **Hitachi AMS 2000 Family Power Savings User Guide** (MK-97DF8045)

Describes how to spin down volumes in selected RAID groups when they are not being accessed by business applications to decrease energy consumption and significantly reduce the cost of storing and delivering information.

## **Command and Control (CCI)**

The following documents describe how to install the Hitachi AMS 2000 Family Command Control Interface (CCI) and use it to perform TrueCopy and ShadowImage operations.

### **Hitachi AMS 2000 Family Command Control Interface (CCI) Installation Guide** (MK-97DF8122)

Describes how to install CCI software on open-system hosts.

### **Hitachi AMS 2000 Family Command Control Interface (CCI) Reference Guide** (MK-97DF8121) — this document

Contains reference, troubleshooting, and maintenance information related to CCI operations on AMS 2100, AMS 2300, and AMS 2500 storage systems.

### **Hitachi AMS 2000 Family Command Control Interface (CCI) User's Guide** (MK-97DF8123)

Describes how to use CCI to perform TrueCopy and ShadowImage operations on AMS 2100, AMS 2300, and AMS 2500 storage systems.

## **Command Line Interface (CLI)**

The following documents describe how to use Hitachi Storage Navigator Modular 2 to perform management and replication activities from a command line.

### **Hitachi Storage Navigator Modular 2 Command Line Interface (CLI) Unified Reference Guide** (MK-97DF8089)

Describes how to interact with all Navigator 2 bundled and optional software modules by typing commands at a command line.

### **Hitachi Storage Navigator 2 Command Line Interface Replication Reference Guide for AMS** (MK-97DF8153)

Describes how to interact with Navigator 2 to perform replication activities by typing commands at a command line.

## **Hitachi Dynamic Replicator documentation**

The following documents describe how to install, configure, and use Hitachi Dynamic Replicator to provide AMS Family storage systems with continuous data protection, remote replication, and application failover in a single, easy-to-deploy and manage platform.

**Hitachi Dynamic Replicator - Scout Release Notes** (RN-99DF8211)

**Hitachi Dynamic Replicator - Scout Host Administration Guide**  
(MK-98DF8212)

**Hitachi Dynamic Replicator - Scout Installation and Configuration Guide** (MK-98DF8213)

**Hitachi Dynamic Replicator - Scout Quick Start Guide** (MK-98DF8214)

**Hitachi Dynamic Replicator - Scout Host Troubleshooting Guide**  
(MK-98DF8215)

**Hitachi Dynamic Replicator DR-Scout ICAT Utility Guide**  
(MK-98DF8216)

**Hitachi Dynamic Replicator - Scout RX Server Deployment Guide**  
(MK-98DF8217)

**Hitachi Dynamic Replicator VX Solution for Oracle (Solaris)**  
(MK-98DF8218)

**Hitachi Dynamic Replicator - Scout Solution for SharePoint 2007**  
(MK-98DF8219)

**Hitachi Dynamic Replicator - Scout Solution for MySQL (Windows)**  
(MK-98DF8220)

**Protecting Citrix XenServer Using Hitachi Dynamic Replicator - Scout** (MK-98DF8221)

**Hitachi Dynamic Replicator Quick Install/Upgrade Guide**  
(MK-98DF8222)

**Hitachi Dynamic Replicator - Scout Protecting MS SQL Server**  
(MK-98DF8223)

**Hitachi Dynamic Replicator - Scout - Protecting Microsoft Exchange Server** (MK-98DF8224)

**Hitachi Dynamic Replicator - Scout File Server Solution**  
(MK-98DF8225)

**Hitachi Dynamic Replicator - Scout ESX - Protecting ESX Server (RCLI)** (MK-99DF8226)

## Regulatory information

The Hitachi AMS 2000 Family storage systems comply with the following regulations:

- US FCC - Class A, Part 15
- Canadian DOC - Class A
- European Declaration of Conformity - EN 55022 class A for ITE
- China RoHS

For more information, refer to the *Hitachi AMS 2100/2300 Storage System Hardware Guide* (MK-97DF8010) and *Hitachi AMS 2500 Storage System Hardware Guide* (MK-97DF8007).

## Getting help

If you have questions after reading this guide, contact an HDS authorized service provider or visit the HDS support website: <http://support.hds.com>

## Support contact information

If you purchased this product from an authorized HDS reseller, contact that reseller for support. For the name of your nearest HDS authorized reseller, refer to the HDS support web site for locations and contact information.

To contact the Hitachi Data Systems Support Center, please visit the HDS website for current telephone numbers and other contact information.

<http://support.hds.com>

Please provide at least the following information about the problem:

- Product name, model number, part number (if applicable) and serial number
- System configuration, including names of optional features installed, host connections, and storage configuration such as RAID groups and LUNs
- Operating system name and revision or service pack number
- The exact content of any error message(s) displayed on the host system(s)
- The circumstances surrounding the error or failure
- A detailed description of the problem and what has been done to try to solve it
- Confirmation that the HDS Hi-Track remote monitoring feature has been installed and tested.



**NOTE:** To help improve the quality of our service and support, your calls may be recorded or monitored.

---

## HDS support web site

The following pages on the HDS support web site contain other further help and contact information:

- Home Page: <http://support.hds.com>

## Interoperability information

Hitachi Data Systems believes that interoperability and industry standards are the keys to simplifying storage management software, exceeding customer expectations, and driving down customer costs. By working with other storage industry leaders, Hitachi Data Systems demonstrates how heterogeneous storage systems can work in concert seamlessly under an open hardware/software umbrella, to the benefit of our mutual customers. Interoperability information about the Hitachi AMS 2100/2300 base and expansion units and other products from Hitachi Data Systems can be obtained from [www.hds.com/products/interoperability](http://www.hds.com/products/interoperability).

## Comments

Please send us your comments on this document: [doc.comments@hds.com](mailto:doc.comments@hds.com). Include the document title, number, and revision, and refer to specific section(s) and paragraph(s) whenever possible.

**Thank you!** (All comments become the property of Hitachi Data Systems Corporation.)



# Introduction

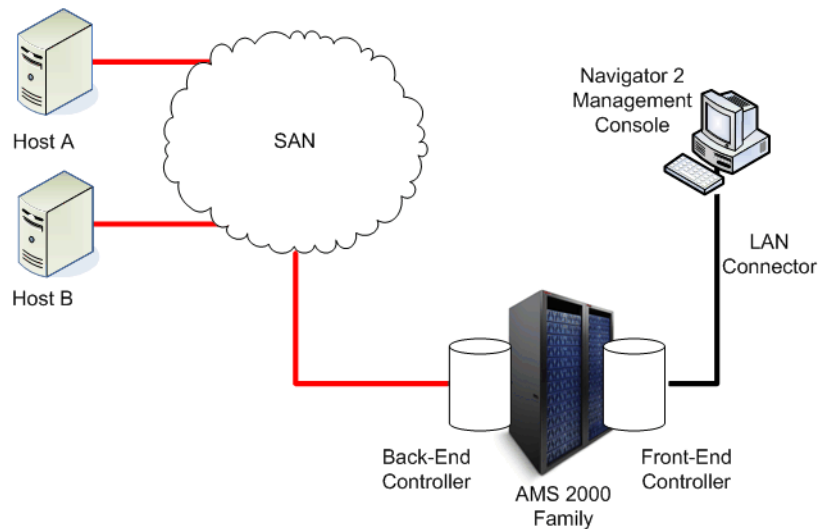
This chapter provides an introduction to Storage Navigator Modular 2 (Navigator 2).

The topics covered in this chapter are:

- ❑ [Navigator 2 at a glance](#)
- ❑ [Key features](#)
- ❑ [Integrating with Hitachi storage features](#)
- ❑ [What this document covers](#)
- ❑ [What this document covers](#)
- ❑ [Using the Navigator 2 online help](#)

## Navigator 2 at a glance

Hitachi Data Systems Navigator 2 empowers you to take advantage of the full power of your Hitachi storage systems. Using Navigator 2, you can configure and manage your storage assets from a local host and from a remote host across an Intranet or TCP/IP network to ensure maximum data reliability, network up-time, and system serviceability. [Figure 1-1](#) details the task flow associated with the Navigator 2 Management Console.



**Figure 1-1: Navigator 2 Task Flow**

[Figure 1-1](#) shows Navigator 2 connects directly to the front-end controller of the AMS 2000 family storage system. The front-end controller communicates to the back-end controller of the storage system, which in turn, communicates with the Storage Area Network (SAN), typically a Fibre Channel switch. Hosts, or application servers, typically contact the SAN to retrieve data from the storage system for use in applications, commonly databases and data processing programs.

The role that the Navigator 2 management console plays is to provide views of feature settings on the storage system in addition to enabling you to configure and manage those features. The following section provides more detail about what features Navigator 2 provides to optimize your experience with the AMS 2000 storage system.

## Key features

Navigator 2 provides the following features:

- Point-and-click graphical interface with initial set-up wizards that simplifies configuration, management, and visualization of Hitachi storage systems.
- An immediate view of available storage and current usage.
- Efficient deployment of storage resources to meet business and application needs, optimize storage productivity, and reduce the time required to configure storage systems and balance I/O workloads.

- Protection of access to information by restricting storage access at the port level, requiring case-sensitive password logins, and providing secure domains for application-specific data.
- Protection of the information itself by letting you configure data-redundancy and assign hot spares.
- Online functions for Hitachi storage systems, such as storage system status, event logging, email alert notifications, and statistics.
- Compatibility with Microsoft® Windows®, UNIX, and Linux environments.
- Online help to enable easy access to information about use of features.
- A full featured and scriptable command line interface. For more information, refer to the following documents:
  - *Hitachi Storage Navigator Modular 2 Command Line Interface Unified User's Guide* (MK-97DF8089)
  - *Hitachi Storage Navigator 2 Command Line Interface (CLI) Replication Reference Guide for AMS* (MK-97DF8153)

## Integrating with Hitachi storage features

In addition to providing native configuration and management features, Navigator 2 provides the full set of Hitachi Storage Features comprising:

- Account Authentication and Audit Logging that provides access control to management functions and records all system changes.
- Performance Monitor software that lets you see performance within the storage system.
- Logical unit number (LUN) Management software that streamlines configuration management processes by letting you define, configure, add, delete, expand, revise, and reassign LUNs to specific paths, without having to reboot your Hitachi storage system.
- SAN Security software that helps ensure security in open systems storage area networking environments through restricted server access
- Replication Setup and Management feature that provides basic configuration and management of Hitachi ShadowImage®, Copy-on-Write, and TrueCopy® mirrored pairs.
- Modular Volume Migration software that enables dynamic data migration.
- Hitachi Cache Residency Manager feature that let you “lock” and “unlock” data into cache in real time to optimize access to your most frequently accessed data.
- Hitachi Cache Partition Manager that allows partitioning of the cache by the application to improve performance.
- Online Redundant Array of Independent Disks (RAID) Group Expansion that enables dynamic addition of drives to a RAID Group.
- System Maintenance feature that allows online controller microcode updates and other system maintenance functions.

- SNMP Agent support that includes Hitachi-specific MIBs, and enables SNMP-based reporting on status and alerts for Hitachi storage systems.

## What this document covers

This document describes key Navigator setup and configuration tasks. The following three tables summarize the setup ([Table 1-1](#)), configuration ([Table 1-2](#)), and upgrade and uninstall ([Table 1-3](#)) tasks in this document. For a complete list of activities that can be performed using Navigator 2, see [Description of Navigator 2 activities on page 5-5](#).

**Table 1-1: Navigator 2 Set-up Tasks**

Task	See Page
Collecting all the items you need to install Navigator 2	<a href="#">2-7</a>
Installing Navigator 2	<a href="#">3-2</a>
Using Navigator 2 with a firewall	<a href="#">2-9</a>
Using Navigator 2 with anti-virus software	<a href="#">2-9</a>
Use Navigator 2 with Secure Sockets Layer (SSL)	<a href="#">10-2</a>
Starting Navigator 2.	<a href="#">4-2</a>
Completing the first-time wizards that appear when you select a Hitachi storage system for the first time.	<a href="#">4-4</a>

**Table 1-2: Navigator 2 Storage Management Tasks**

Task	See Page
Change the default password. For security, we recommend you use this information to change the default Navigator 2 password after logging in to Navigator 2 the first time.	<a href="#">6-6</a>
Define Navigator 2 administrators and users.	<a href="#">6-2</a>
Add storage systems (using the Add Arrays wizard)	<a href="#">4-5</a>
Editing storage system settings.	<a href="#">7-5</a>
Removing storage systems on	<a href="#">7-8</a>
Manage spare drives	<a href="#">5-5</a>
Define a RAID group, add logical units to it, and modify it	<a href="#">8-1</a>
Create, edit, and remove logical units	<a href="#">9-1</a>

**Table 1-3: Navigator 2 Storage Maintenance Tasks**

Task	See Page
Upgrade Navigator 2	<a href="#">A-1</a>
Uninstall Navigator 2	<a href="#">B-1</a>

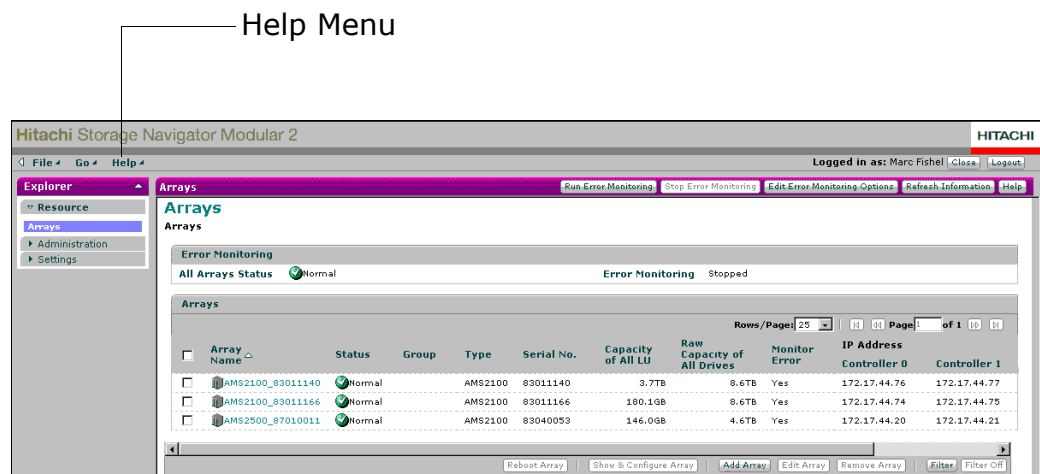
Task	See Section and Page
Upgrade Navigator 2	<a href="#">Appendix A, Upgrading Navigator 2</a>
Uninstall Navigator 2	<a href="#">Appendix B, Uninstalling Navigator 2</a>

## Using the Navigator 2 online help

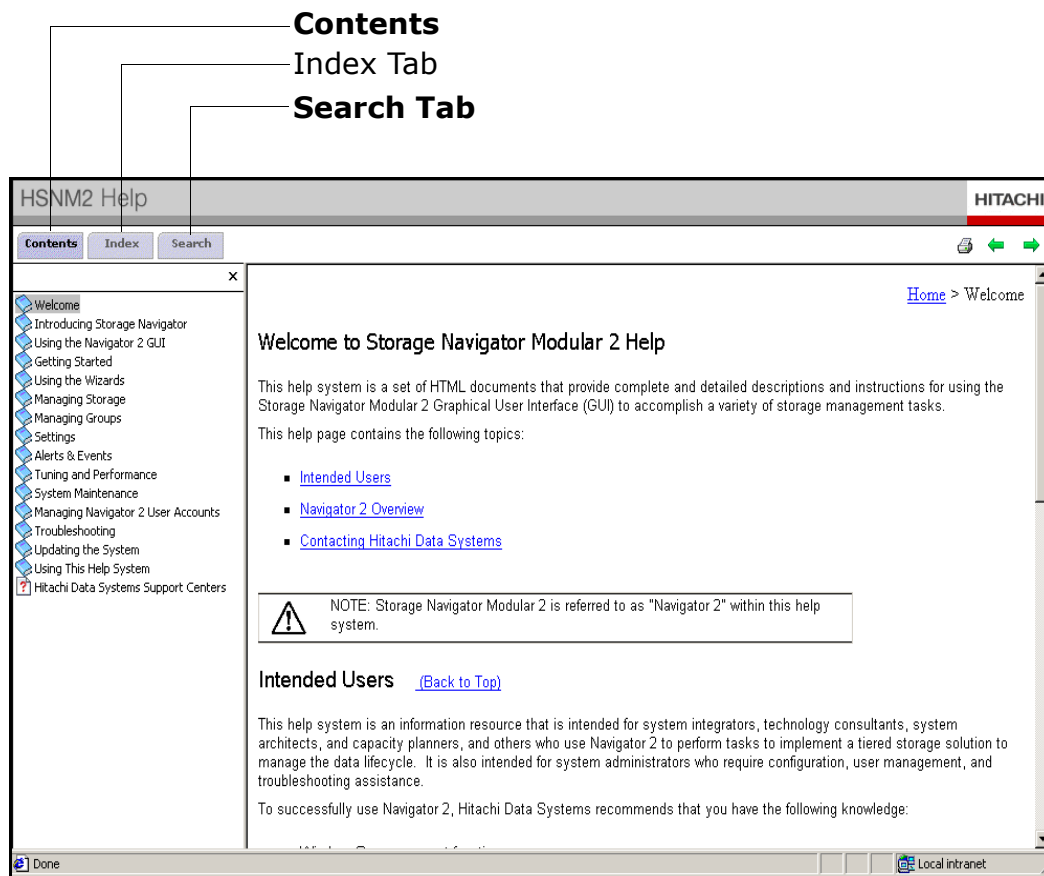
This document covers many, but not all, of the features in Navigator 2 software. Therefore, if you need information about a Navigator 2 function that is not included in this document, please refer to the Navigator 2 online help in the Navigator GUI. To access the help, click the **Help** button on the Navigator 2 GUI and select **Help**. For convenience, the **Help** button is available regardless of the window displayed in Navigator 2.

The online help provides several layers of assistance.

- The **Contents** tab shows how the help topics are organized. You can “drill down” the topics to quickly find the support topic you are looking for, and then click a topic to view it.
- The **Index** tab lets you search for information related to a keyword. Type the keyword in the field labeled **Type in the keyword to find:** and the nearest match in the Index is highlighted. Click an index entry to see the topics related to the word. Click a topic to view it. If only one topic is related to an index entry, it appears automatically when you click the entry.
- The **Search** tab lets you scan through every help topic quickly for the word or words you are looking for. Type what you are looking for in the field labeled **Type in the word(s) to search for:** and click **Go**. All topics that contain that text are displayed. Click a topic to view it. To highlight your search results, check **Highlight search results**.



**Figure 1-2: Help Menu**



**Figure 1-3: Home Page of the Navigator 2 Online Help**

# Preinstallation Information

This chapter provides information you should review before installing Navigator 2. This chapter begins with the definitions for key terms associated with Navigator 2.

The topics covered in this chapter are:

- [Understanding Navigator 2 key terms](#)
- [Quick-start checklist](#)
- [Navigator 2 operating environment](#)
- [Collecting user-supplied items](#)
- [Installing Java runtime](#)
- [Firewall considerations](#)
- [Anti-virus software considerations](#)
- [Obtaining license keys](#)
- [Reviewing technical guidelines](#)

## Understanding Navigator 2 key terms

Before you install the Navigator 2 software, it is important to understand a few key terms associated with Navigator 2. [Table 2-1](#) defines a few key terms associated with Navigator 2.

**Table 2-1: Understanding Navigator 2 Key Terms**

Term	Explanation
Host group	A group that virtualizes access to the same port by multiple hosts since host settings for a LUN are not made at the physical port level but at a virtual port level.
Profile	A set of attributes that are used to create a storage pool. The system has a predefined set of storage profiles. You can choose a profile suitable for the application that is using the storage, or you can create a custom profile.
Pool	A collection of volumes with the same configuration. A storage pool is associated with a storage profile, which defines the storage properties and performance characteristics of a volume.
Snapshot	A point-in-time copy of a primary volume. The snapshot can be mounted by an application and used for backup, application testing, or data mining without requiring you to take the primary volume offline.
Storage domain	A logical entity used to partition storage.
Volume	A container into which applications, databases, and file systems store data. Volumes are created from virtual disks, based on the characteristics of a storage pool. You map a volume to a host or host group.
RAID	Redundant Array of Independent Disks (RAID) — A disk array in which part of the physical storage capacity is used to store redundant information about user data stored on the remainder of the storage capacity. The redundant information enables regeneration.
Parity Disk	A RAID-3 disk that provides redundancy. RAID-3 distributes the data in stripes across all but one of the disks in the array. It then writes the parity in the corresponding stripe on the remaining disk. This disk is the parity disk.
LUN	Logical unit number (LUN) — An address for an individual disk drive, and by extension, the disk device itself. Used in the SCSI protocol as a way to differentiate individual disk drives within a common SCSI target device, like a disk array. LUNs are normal.
iSCSI	Internet-Small Computer Systems Interface (iSCSI) — A TCP/IP protocol for carrying SCSI commands over IP networks.
iSCSI Target	A system component that receives an iSCSI I/O command. The command is sent to the iSCSI bus address of the target device or controller.
iSCSI Initiator	The component that transmits an iSCSI I/O command to the iSCSI bus address of the target device or controller.

## Quick-start checklist

Table 2-2 describes the steps for installing Navigator 2. For more information about a step, refer to the section in the See column. Make copies of the checklist for each installation performed and check each step after you perform it. Keep the blank checklist in this guide for future use.

**Table 2-2: Navigator 2 Installation Checklist**

Step	Description	See	Completed
1.	Install your AMS 2000 hardware and confirm that it is operational.	Your Hitachi AMS 2000 Family storage system hardware guide	<input type="checkbox"/>
2.	Meet all operating environment requirements.	<a href="#">page 2-3</a>	<input type="checkbox"/>
3.	Collect all user-supplied items required for the Navigator 2 installation.	<a href="#">page 2-7</a>	<input type="checkbox"/>
4.	Install and set Java Runtime Environment (JRE) v6.0.	<a href="#">page 2-7</a>	<input type="checkbox"/>
5.	Disable your firewall.	<a href="#">page 2-9</a>	<input type="checkbox"/>
6.	Disable your anti-virus software.	<a href="#">page 2-9</a>	<input type="checkbox"/>
7.	Obtain license keys for all Hitachi Program Products you want to install using Navigator 2.	<a href="#">page 2-10</a>	<input type="checkbox"/>
8.	Review the Navigator 2 technical guidelines.	<a href="#">page 2-10</a>	<input type="checkbox"/>

## Navigator 2 operating environment

You install Navigator 2 on a management platform (either a PC, a Linux workstation, or a laptop) that acts as a console for managing your AMS 2000 Family storage system. This PC management console connects to the management ports on the AMS 2000 Family storage system controllers, and uses Navigator 2 to manage your storage assets and resources. The management console can connect directly to the management ports on the AMS 2000 Family storage system or via a network hub or switch.

Before installing Navigator 2 on the management console, confirm that the console meets the requirements in the following sections. For an optimum Navigator 2 experience, the management console should be a new or dedicated PC.



**TIP:** To obtain the latest compatibility information about supported operating systems, NICs, and various devices, see the Hitachi Data Systems interoperability matrix at <http://www.hds.com/products/interoperability/>.

## Microsoft Windows operating systems

Table 2-3 lists the Navigator 2 requirements for management consoles running a supported Microsoft Windows operating system. For information about supported Microsoft Windows servers and their requirements, see:

- The Hitachi AMS 2100/2300 Getting Started Guide (MK-98DF8152EN)
- The Hitachi AMS 2500 Getting Started Guide (MK-97DF8032EN)
- The interoperability matrix at <http://www.hds.com/products/interoperability/>

**Table 2-3: Requirements for Management Consoles Running Microsoft Windows Operating Systems**

Item	Requirement
Operating systems	<ul style="list-style-type: none"> <li>• Windows 2000 (x86), SP3, SP4</li> <li>• Windows XP (x86), SP2, SP3 (Internet Explorer v7.0 is not supported on SP3)</li> <li>• Windows Server 2003 (x86), SP1, SP2</li> <li>• Windows Server 2003 R2 (x86), No SP, SP2</li> <li>• Windows Server 2003 R2 (x64), No SP, SP2</li> <li>• Windows Vista (x86), SP1</li> <li>• Windows Server 2008 (x86), no SP, SP2</li> <li>• Windows Server 2008 (x64), no SP, SP2</li> <li>• Windows 7 (x86), no SP</li> <li>• Windows 7 (x64), no SP</li> <li>• Windows Server 2008 R2 (x64), no SP</li> <li>• Windows XP and Windows Server 2003 R2 operating as a guest OS of VMware ESX Server 3.1.x</li> </ul>
Processor	1 GHz (2 GHz or faster recommended)
Random Access Memory	1 GB (2 GB or more recommended)
Available disk space	1 GB or more
Video resolution	800 x 600 dots per inch (1024 x 768 or higher recommended), 256 colors or more
Browser (with pop-up blockers disabled)	<ul style="list-style-type: none"> <li>• Internet Explorer v6.0 (SP1, SP2)</li> <li>• Internet Explorer v7.0</li> <li>• 64-bit Internet Explorer v6.0 (SP1, SP2) on Windows Server 2003 R2 (x64)</li> <li>• 64-bit Internet Explorer v7.0 on Windows Server 2008 (x64)</li> <li>• Internet Explorer v8.0 (x86, x64) on Windows 7 and Windows Server 2008 R2</li> </ul>
Java Runtime Environment (JRE)	JRE v1.6.0_15

## Sun Solaris operating systems

Table 2-4 lists the Navigator 2 requirements for management consoles running a supported Sun Solaris operating system. For information about supported Sun Solaris hosts and their requirements, see:

- The Hitachi AMS 2100/2300 Getting Started Guide (MK-98DF8152EN)
- The Hitachi AMS 2500 Getting Started Guide (MK-97DF8032EN)
- The interoperability matrix at <http://www.hds.com/products/interoperability/>

**Table 2-4: Requirements for Management Consoles Running Sun Solaris**

Item	Requirement
Operating systems	<ul style="list-style-type: none"><li>• Solaris 8 (SPARC)</li><li>• Solaris 9 (SPARC)</li><li>• Solaris 10 (SPARC)</li><li>• Solaris 10 (x86)</li><li>• Solaris 10 (x64)</li></ul>
Processor	<ul style="list-style-type: none"><li>• SPARC: 1 GHz (2 GHz or faster recommended)</li><li>• Solaris 10 (x64): 1.8 GHz (2 GHz or faster recommended)</li></ul>
Random Access Memory	1 GB (2 GB or more recommended)
Available disk space	1 GB or more
Video resolution	800 x 600 dots per inch (1024 x 768 or higher recommended), 256 colors or more
Browser (with pop-up blockers disabled)	<ul style="list-style-type: none"><li>• Mozilla v1.7</li><li>• Firefox 2</li></ul>
JRE	JRE v1.6.0_15

## Red Hat Linux operating systems

Table 2-5 on page 2-6 lists the Navigator 2 requirements for management consoles running a supported Red Hat Linux operating system. For information about supported Red Hat Linux hosts and their requirements, see:

- The Hitachi AMS 2100/2300 Getting Started Guide (MK-98DF8152EN)
- The Hitachi AMS 2500 Getting Started Guide (MK-97DF8032EN)
- The interoperability matrix at <http://www.hds.com/products/interoperability/>

**Table 2-5: Requirements for Management Consoles Running Red Hat Linux**

Item	Requirement
Operating systems	<ul style="list-style-type: none"> <li>Red Hat Enterprise Linux AS 4.0 update 1</li> <li>Red Hat Enterprise Linux AS 4.0 update 5</li> </ul>
Processor	1 GHz (2 GHz or faster recommended)
Random Access Memory	1 GB (2 GB or more recommended)
Available disk space	1 GB or more
Video resolution	800 x 600 dots per inch (1024 x 768 or higher recommended), 256 colors or more
Browser (with pop-up blockers disabled)	Mozilla v1.7
JRE	JRE v1.6.0_15

## Network requirements

The management console can be used with the items in [Table 2-6](#).

**Table 2-6: Network Requirements**

Item	Description
Network Interface Card (NIC)	For supported NICs, see the interoperability matrix at <a href="http://www.hds.com/products/interoperability/">http://www.hds.com/products/interoperability/</a> .
Ethernet cable	The management ports support Auto-MDI/MDIX technology, allowing you to use either standard (straight-through) or crossover Ethernet cables.
Switch or hub	<ul style="list-style-type: none"> <li>For Fibre Channel networks, use a Fibre Channel switch or hub.</li> <li>For iSCSI networks, use an iSCSI switch or hub.</li> </ul>

## Collecting user-supplied items

Before installing Navigator 2, be sure you have the following user-supplied items.

- Navigator 2 installation CDs or access to the Hitachi Data Systems Web Portal: [support.hds.com](http://support.hds.com).
- A PC that will act as the management console for managing the storage system using Navigator 2. See [Navigator 2 operating environment on page 2-3](#).
- The IP address of each management port on your AMS 2000 Family storage system that will connect to the Navigator 2 management console. Refer to the document for your AMS hardware.
- The IP address of the management console. See [Getting started \(all users\) on page 3-2](#).
- The port number used to access Navigator 2 from your browser. The default port is 1099.
- The password you will use to replace the default system account password.
- License keys required by each program product you want to use. See [Obtaining license keys on page 2-10](#).

## Installing Java runtime

If the management console does not have the required version of JRE installed, as indicated under [Navigator 2 operating environment on page 2-3](#)), use the procedures in the following sections to download and install it.

### Downloading and installing JRE

You can download JRE from the following site and install it by following the on-screen prompts:

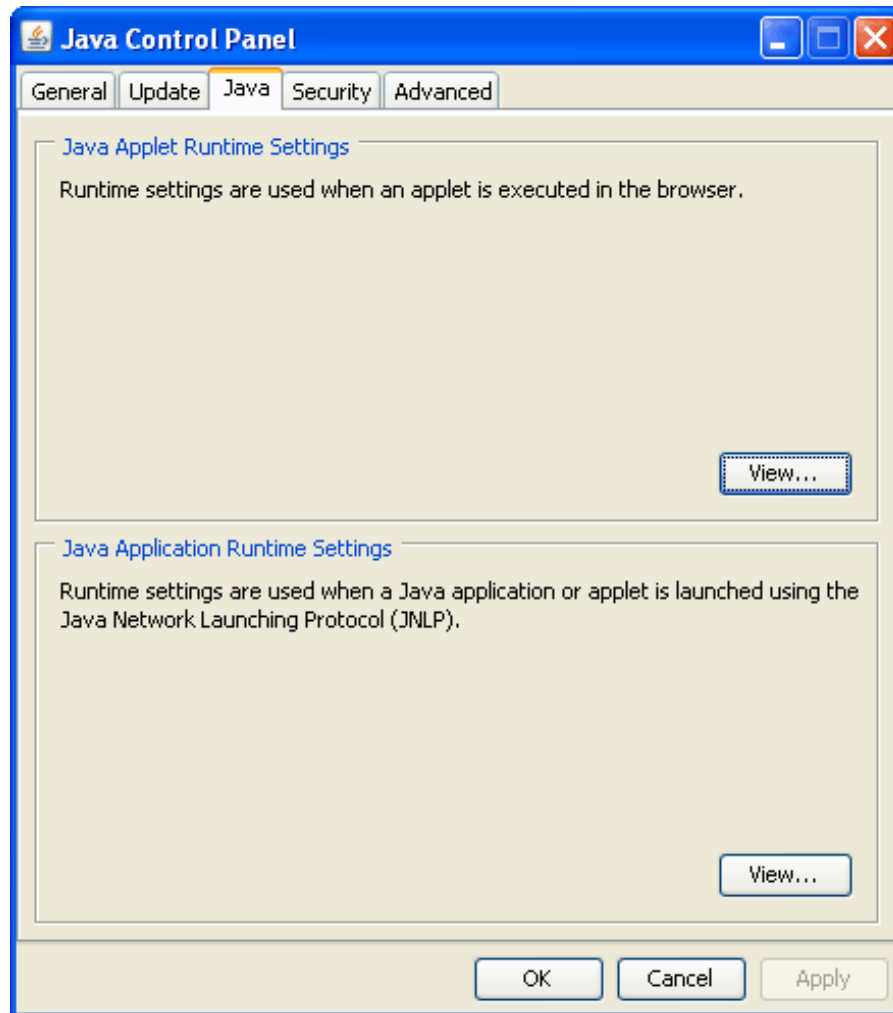
<http://java.com/en/download/>

After installing JRE v6.0, refer to the appropriate section that follows to complete the installation for the operating system running on the management console.

### Clients running Microsoft Windows

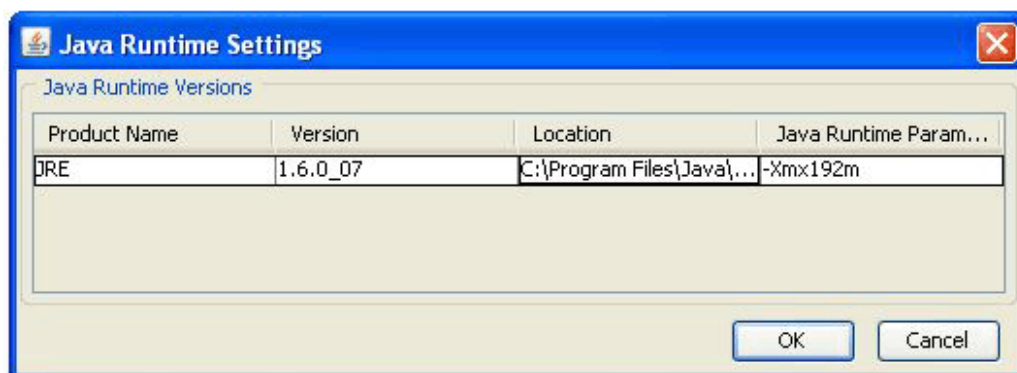
If your management console runs Microsoft Windows, perform the following procedure.

1. Click the Windows Start menu, point to **Settings**, and click **Control Panel**. The Windows Control Panel appears.
2. In the Windows Control Panel, double-click **Java Control Panel**. The Java Control Panel appears.
3. Click the **Java** tab. The **Java** tab appears (see [Figure 2-1 on page 2-8](#)).



**Figure 2-1: Java Tab**

4. Click **View** in the **Java Applet Runtime Settings** section. The Java Runtime Settings dialog box appears.
5. In the **Java Runtime Parameters** field, type **-Xmx192m** (see [Figure 2-2](#)).



**Figure 2-2: Java Runtime Settings Dialog Box**

6. Click **OK** to exit the Java Runtime Settings window.

7. Click **OK** in the **Java** tab to close the Java Control Panel window.
8. Close the Windows Control Panel.

## Clients running Solaris or Linux

If your management console runs a supported Solaris or Linux operating system, perform the following procedure.

1. From an XWindows terminal, execute the `<JRE installed directory>/bin/jcontrol` to run the Java Control Panel.
2. Click **View** in the **Java Applet Runtime Settings** section. The Java Runtime Settings window appears.
3. In the **Java Runtime Parameters** field, type **-Xmx192m**.
4. Click **OK** to exit the Java Runtime Settings window.
5. Click **OK** in the **Java** tab to close the Java Control Panel window.

## Firewall considerations

A firewall's main purpose is to block incoming unsolicited connection attempts to your network. If the AMS 2000 Family storage system is used within an environment that uses a firewall, there will be times when the storage system's outbound connections will need to traverse the firewall.

The storage system's incoming indication ports are ephemeral, with the system randomly selecting the first available open port that is not being used by another Transmission Control Protocol (TCP) application. To permit outbound connections from the storage system, you must either disable the firewall or create or revise a source-based firewall rule (not a port-based rule), so that items coming from the storage system are allowed to traverse the firewall.

Firewalls should be disabled when installing Navigator 2 (refer to the documentation for your firewall). After the installation completes, you can turn on your firewall.



**NOTE:** For outgoing traffic from the storage system's management port, there are no fixed port numbers (ports are ephemeral), so all ports should be open for traffic from the storage system management port.

---

If you use Windows firewall, the Navigator 2 installer automatically registers the Navigator 2 file and Command Suite Common Components as exceptions to the firewall. Therefore, before you install Navigator 2, confirm that no security problems exist.

## Anti-virus software considerations

Anti-virus programs, except Microsoft Windows' built-in firewall, must be disabled before installing Navigator 2. In addition, Navigator 2 cannot operate with firewalls that can terminate local host socket connections. As a result, configure your anti-virus software to prevent socket connections from being terminated at the local host (refer to the documentation for your anti-virus software).

## Obtaining license keys

Some Program Products require a license key before you can use them. Typically, the license key required to activate these products is furnished with the product. We recommend that you have these license keys available before you activate the Program Products that require them. If you do not have license keys for the Program Products, please contact technical support.

## Reviewing technical guidelines

The following sections cover technical guidelines to review before installing Navigator 2 on a management console.

### Windows operating systems

#### Installation prerequisites

Before installing Navigator 2 on a management console running one of the supported Microsoft Windows operating systems in [Table 2-3 on page 2-4](#):

- Log in to Windows as an Administrator or a member of the Administrators group.
- Disable power management through Windows to prevent the host from entering suspension mode.

#### Selecting a destination folder

During the Navigation 2 installation, you are prompted to select a destination folder. You can accept the default destination folder or select a different destination folder.

If you select a different destination folder, be sure the folder complies with the following requirements:

- The folder name should only contain the characters A to Z, a to z, 0 to 9, hash mark (#), plus sign (+), hyphen (-), period (.), at mark (@), underscore (\_), and the space character.
- A space character cannot appear at the beginning or end of a folder name.
- The path name cannot contain any names reserved by the operating system (for example, CON, AUX, NUL, PRN, CLOCK\$, COM1 to COM9, and LPT1 to LPT9).
- The path to the destination folder cannot exceed 100 characters.
- The path to the destination folder cannot be a route to a drive. Otherwise, the installer displays the following error message during the installation.
- Do not specify a Uniform Naming Convention (UNC) path.

# Solaris and Linux operating systems

## Installation prerequisites

Before installing Navigator 2 on a management console running one of the supported Solaris and Linux operating systems in [Table 2-3 on page 2-4](#):

- Log on as a root user.
- If `/opt` exists, the normal directory is required, not the symbolic link. However, the file system can be mounted as a mount point.
- For Solaris v10 (SPARC), apply the appropriate patch.
  - Apply patch 120664-xx (where xx is 01 or later).
  - Apply patch 127127-xx (where xx is 11 or later).
  - Do not apply patches 127111-02 and 127111-03.
- For Solaris v10 (x64), apply patch 120665-xx (where xx is 01 or later)
- For Linux, set the kernel parameters described in the following sections.

## Setting Linux kernel parameters

To set the Linux kernel parameters:

1. Back up the kernel parameters setting files `/etc/sysctl.conf` and `/etc/security/limits.conf`.
2. Open the kernel parameters setting file `/etc/sysctl.conf` with a text editor and change the following settings. The parameters are specified using the syntax `[name of parameter]=[value]`. Four values separated by space are specified in `kernel.sem`. Your parameter settings must not exceed the maximum value for the operating system.

The following example shows how to check whether the value is valid for `kernel.shmmax`:

```
cat /proc/sys/kernel/shmmax
```

[Table 2-7](#) provides recommended values and calculation methods for each kernel type.

**Table 2-7: Kernel Type Recommended Values**

Parameter Name	Recommended Value		Calculation Method
	Navigator 2	Database	
kernel.shmmax	11542528	200000000	Maximum value in current and two recommended values.
kernel.shmall	22418432	22418432	Total value of current and recommended values.

**Table 2-7: Kernel Type Recommended Values (Continued)**

Parameter Name	Recommended Value		Calculation Method
	Navigator 2	Database	
kernel.shmmni	0	2000	The larger value of: <ul style="list-style-type: none"> <li>• The total value of current and Navigator 2 recommended value.</li> <li>• The database recommended value.</li> </ul>
kernel.threads-max	184	574	
kernel.msgmni	32	32	
kernel.sem (Second parameters)	80	7200	
kernel.sem (Forth parameters)	9	1024	
fs.file-max	53898	53898	

Open the kernel parameters setting file `/etc/security/limits.conf` with a text editor and change the following settings. The parameters are specified using the syntax `[domain] [type] [name of parameter] [value]`. Domains are specified for `"*"`. The types are specified for both `"soft"` and `"hard."` The soft value must not exceed the hard value. Then, the parameter must not exceed the maximum value that the operating system specifies. [Table 2-8](#) shows the recommended values and calculation methods for the kernel parameter types.

**Table 2-8: Kernel Parameter Recommended Values**

Parameter Name	Recommended Value		Calculation Method
	Navigator 2	Database	
nofile	572	1344	The larger value of: <ul style="list-style-type: none"> <li>• The total value of current and Navigator 2 recommended value.</li> <li>• The database recommended value.</li> </ul>
nproc	165	512	

3. Reboot the host.

### Setting Solaris v8 or Solaris v9 kernel parameters

When installing Navigator 2 on a management console running Solaris v8 or Solaris v9, set the Solaris kernel parameters.

1. Back up the kernel parameters setting file `/etc/system`.

2. Open the kernel parameters setting file `/etc/system` with a text editor and add the following text lines to the bottom of the file. For information about maximum values permitted, refer to the manual for your operating system.

```
set msgsys:msginfo_msgmni=82
set msgsys:msginfo_msgtql=520
set semsys:seminfo_semmni=1024
set semsys:seminfo_semmns=7200
set semsys:seminfo_semmnu=1024
set semsys:seminfo_semume=512
set semsys:seminfo_semmsl=128
set semsys:seminfo_semopm=128
set shmsys:shminfo_shmmax=200000000
set shmsys:shminfo_shmmni=2000
set shmsys:shminfo_shmseg=240
```



**NOTE:** Although the parameter `shmsys:shminfo_shmseg` is not used in Solaris 9, it will not affect Solaris 9 operations if it is included.

3. Reboot the Solaris host and install Navigator 2.

### Setting Solaris v10 kernel parameters

When installing Navigator 2 on a management console running Solaris v10, set the Solaris kernel parameters.

1. Back up the kernel parameters setting file `/etc/project`.
2. In the console, execute the following command and check the current parameter value.

```
projmod -a -K 'process.max-msg-messages=(priv,480,deny)' 'user.root'
projmod -a -K 'process.max-sem-nsems=(priv,128,deny)' 'user.root'
projmod -a -K 'process.max-sem-ops=(priv,128,deny)' 'user.root'
projmod -a -K 'project.max-msg-ids=(priv,32,deny)' 'user.root'
projmod -a -K 'project.max-sem-ids=(priv,1024,deny)' 'user.root'
projmod -a -K 'project.max-shm-ids=(priv,2000,deny)' 'user.root'
projmod -a -K 'project.max-shm-memory=(priv,26214400,deny)' 'user.root'
projmod -a -K 'process.max-msg-messages=(priv,480,deny)' 'system'
projmod -a -K 'process.max-sem-nsems=(priv,128,deny)' 'system'
projmod -a -K 'process.max-sem-ops=(priv,128,deny)' 'system'
projmod -a -K 'project.max-msg-ids=(priv,32,deny)' 'system'
projmod -a -K 'project.max-sem-ids=(priv,1024,deny)' 'system'
projmod -a -K 'project.max-shm-ids=(priv,2000,deny)' 'system'
projmod -a -K 'project.max-shm-memory=(priv,26214400,deny)' 'system'
```

3. Reboot the Solaris host and install Navigator 2.



**NOTE:** If the kernel parameters are not enabled in Solaris v10, open the file `/etc/system` with a text editor and change the following settings before rebooting host.

The console displays the following output.

```
set msgsys:msginfo_msgmni=128
set msgsys:msginfo_msgtql=8192
set semsys:seminfo_semmni=1024
set semsys:seminfo_semmsl=512
set semsys:seminfo_semopm=512
set shmsys:shminfo_shmmax=262144000
set shmsys:shminfo_shmmni=2000
```

## Hitachi Storage Command Suite common component considerations

Before installing Navigator 2, be sure no products other than Hitachi Storage Command Suite Common Component are using port numbers 1099, 23015 to 23018, 23032, and 45001 to 49000. If other products are using these ports, you cannot start Navigator 2, even if the Navigator 2 installation completes without errors.

If other Hitachi Storage Command products are running:

- Stop the services or daemon process for those products.
- Be sure any installed Hitachi Storage Command Suite Common Components are not operating in a cluster configuration. If the host is in the cluster configuration, configure it for a stand-alone configuration according to the manual.
- Back up the Hitachi Storage Command database before installing Navigator 2.

## Installing Navigator 2

After ensuring that your configuration meets the system requirements described in the previous chapter, use the instructions in this chapter to install the Navigator 2 software on your management console PC.

The topics covered in this chapter are:

- ❑ [Types of installations](#)
- ❑ [Installing Navigator 2](#)

## Types of installations

Navigator 2 supports two types of installations:

- Interactive installations — attended installation that displays graphical windows and requires user input.
- Silent installations — unattended installation using command-line parameters that do not require any user input.

This chapter describes the interactive installation procedure. For information about performing silent installations using CLI commands, refer to the *Hitachi Storage Navigator Modular 2 Command Line Interface (CLI) User's Guide* (MK-97DF8089) or the Navigator 2 online help.

Before proceeding, be sure you reviewed and completed all pre-installation requirements described in [Chapter 2, Preinstallation Information](#).

## Installing Navigator 2

The following sections describe how to install Navigator 2 on a management console running one of the Windows, Solaris, or Linux operating systems that Navigator 2 supports (see [Chapter 2, Preinstallation Information](#)).

During the Navigator installation procedure, the installer creates the directories `_HDBInstallerTemp` and `StorageNavigatorModular`. You can delete these directories if necessary.

To perform this procedure, you need the IP address (or host name) and port number that will be used to access Navigator 2. Avoid port number 1099 if this port number is available and use a port number such as 2500 instead.



**NOTE:** Installing Navigator 2 also installs the Hitachi Storage Command Suite Common Component. If the management console has other Hitachi Storage Command products installed, the Hitachi Storage Command Suite Common Component overwrites the current Hitachi Storage Command Suite Common Component.

---

## Getting started (all users)

To start the Navigator 2 installation procedure, all users perform the following steps.

1. Find out the IP address of the management console (e.g., using **ipconfig** on Windows or **ifconfig** on Solaris and Linux). This is the IP address you use to log in to Navigator 2, so long as it is a static IP address. Record this IP address in [Table C-1](#). You will be prompted for it during the Navigator 2 installation procedure.



**NOTE:** On Hitachi storage systems, the default IP addressed for the management ports are 192.168.0.16 for Controller 0 and 192.168.0.17 for Controller 1.

---

2. Disable pop-up blockers in your Web browser. We also recommend that you disable anti-virus software and proxy settings on the management console when installing the Navigator 2 software.

3. Proceed to the appropriate section for the operating system running on your management console:
  - Microsoft Windows. See [Installing Navigator 2 on a Windows operating system](#), below.
  - Solaris. See [Installing Navigator 2 on a Sun Solaris operating system](#).
  - Red Hat Enterprise Linux 4 and Red Hat Enterprise Linux 4 Linux. See [Installing Navigator 2 on a Red Hat Linux operating system on page 3-11](#).

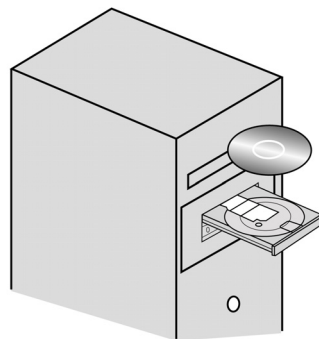
The installation process takes about 15 minutes to complete. During the installation, the progress bar can pause for several seconds. This is normal and does not mean the installation has stopped.

## Installing Navigator 2 on a Windows operating system

The following procedure describes how to install Navigator 2 on a Navigator 2-supported version of Microsoft Windows.

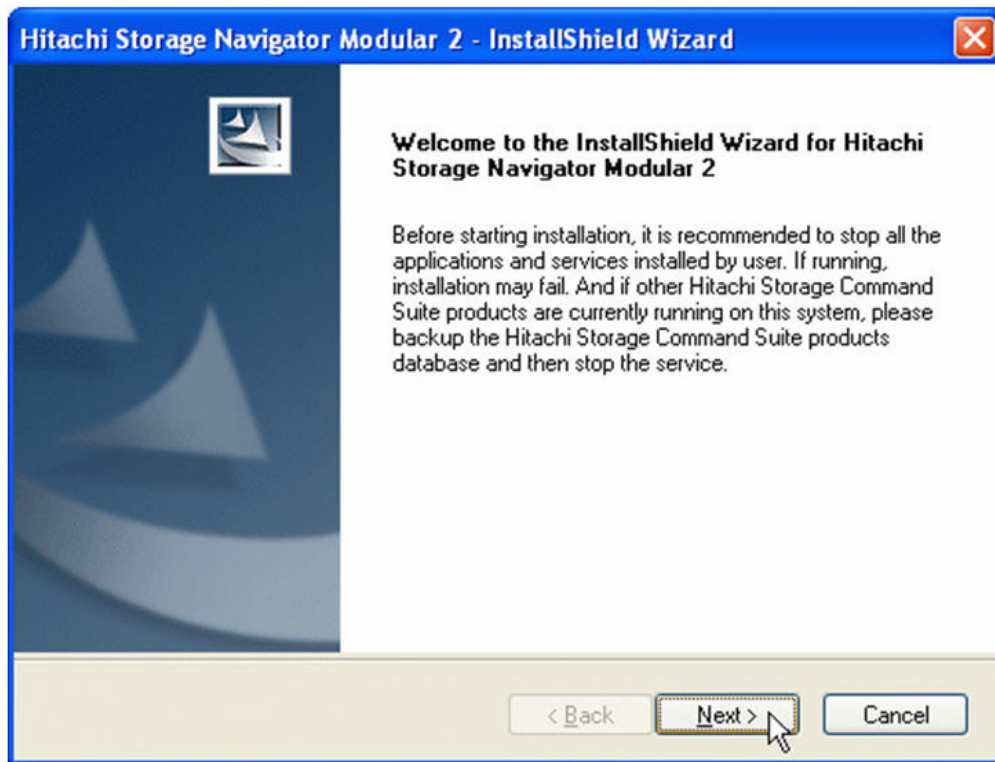
1. Windows Vista users: Open the command prompt and then close it.
2. Insert the Navigator 2 CD in the management console CD drive as shown in [Figure 3-1](#) and follow the installation wizard. If the CD does not auto-run, double-click the following file, where *nnnn* is the Navigator 2 version number:

```
\program\hsm2_win\HSNM2-nnnn-W-GUI.exe
```



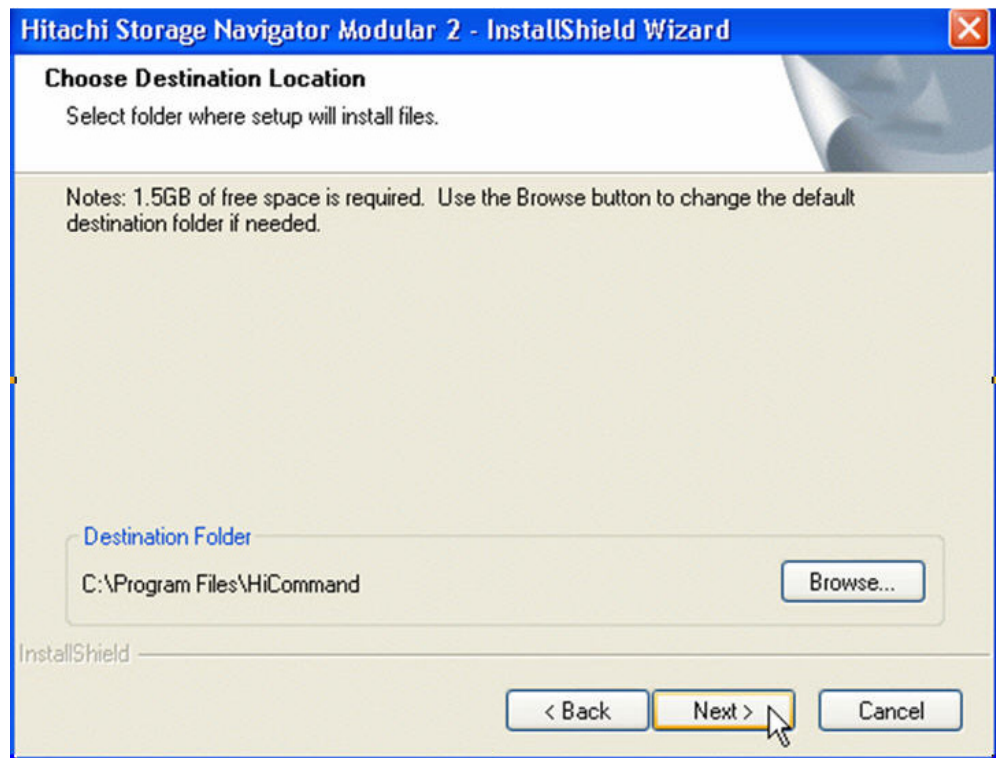
**Figure 3-1: Management Console CD Drive**

3. When prompted for an IP address, enter the IP address for your management console, which you obtained in step 1 and recorded in [Table C-1 on page C-2](#).
4. After you insert the Hitachi Storage Navigator Modular 2 installation CD-ROM into the management console's CD/DVD-ROM drive, the installation starts automatically and the Welcome window appears as shown in [Figure 3-2](#).



**Figure 3-2: Navigator 2 Welcome Window**

5. Click **Next** two times until the Choose Destination Location window appears.



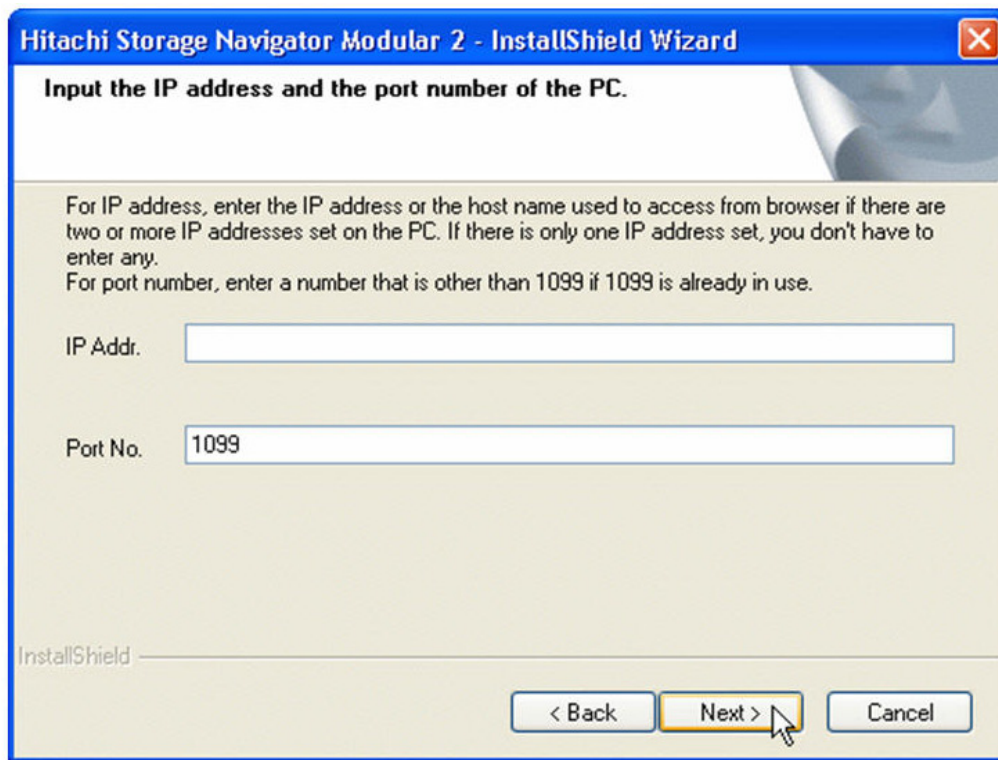
**Figure 3-3: Choose Destination Location Window**

6. Install Navigator 2 in the default destination folder shown or click the **Browse** button to select a different destination folder.



**NOTE:** Select a different destination folder, see [Selecting a destination folder on page 2-10](#).

7. Click **Next**. The Input the IP address and port number of the PC window appears.



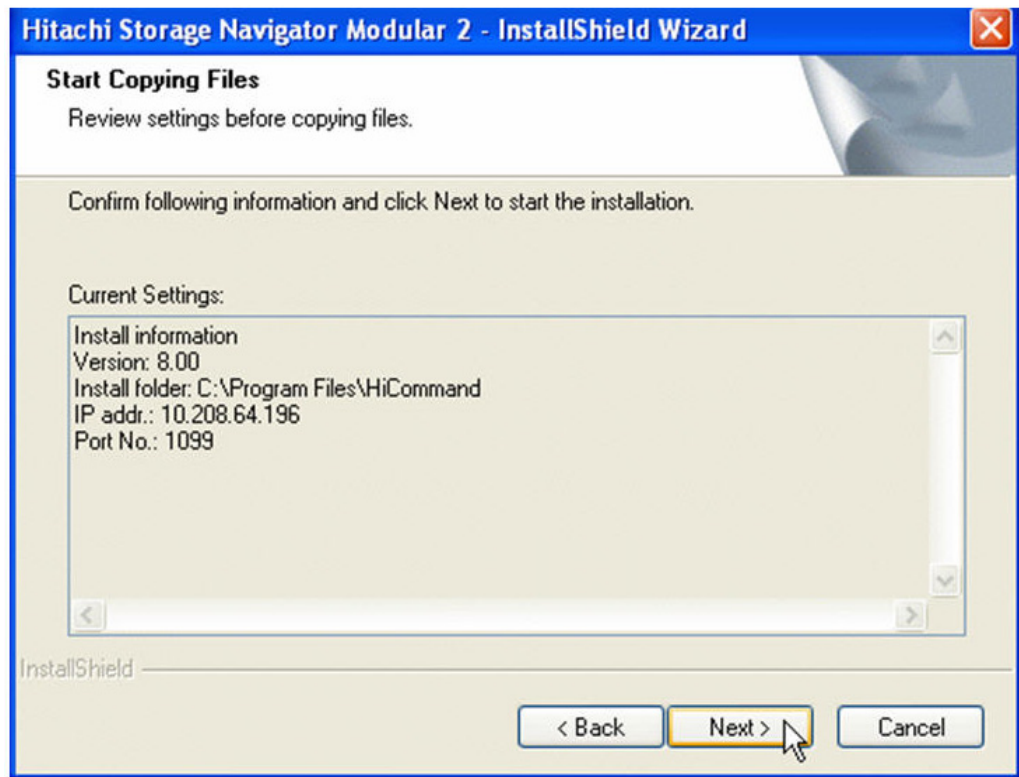
**Figure 3-4: Input the IP Address and Port Number of the PC Window**

8. Enter the following information:
  - **IP Addr.** Enter the IP address or host name used to access Navigator 2 from your browser. Do not specify 127.0.0.1 and localhost.
  - **Port No.** Enter the port number used to access Navigator 2 from your browser. The default port number is 1099.

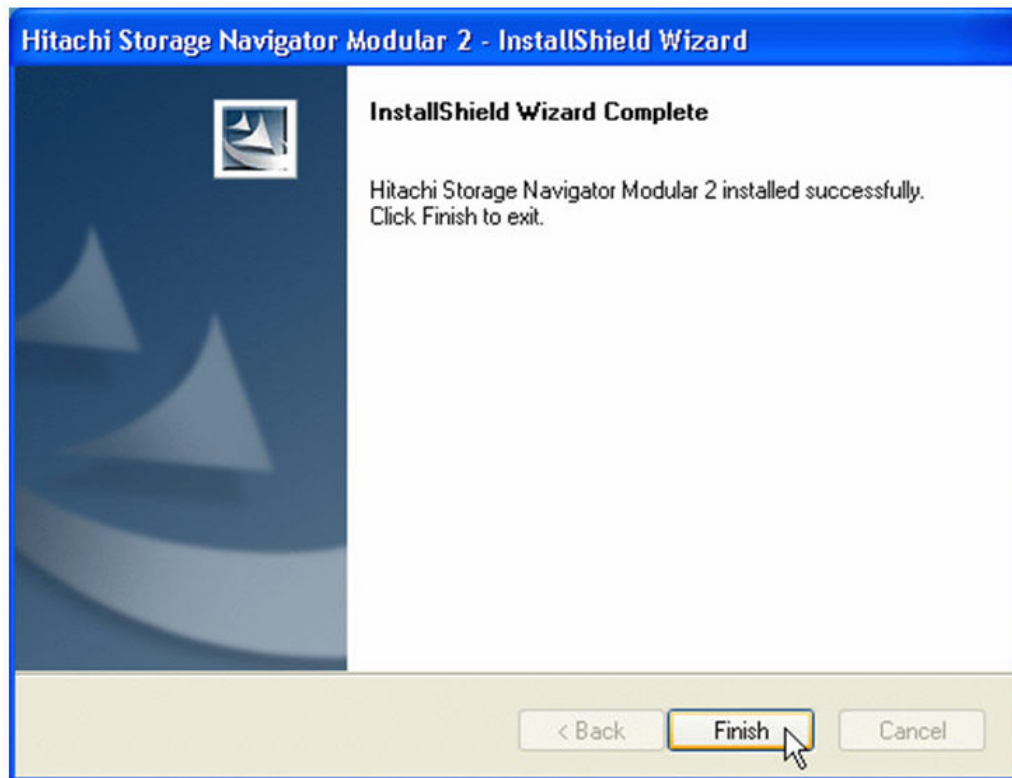


**TIP:** For environments using Dynamic Host Configuration Protocol (DHCP), enter the host name (computer name) for the IP address. If you are configuring Navigator 2 for one IP address, you can omit the **IP Addr.**

9. Click **Next**. The Start Copying Files window shows the installation settings you selected.



10. Review the settings to make sure they are correct. To change any, click **Back** until you return to the appropriate window, make the change, and click **Next** until you return to the Start Copying Files window.
11. In the Start Copying Files window, click **Next** to start the installation. During the installation, windows show the progress of the installation. When installation is complete, the InstallShield Wizard Complete window appears. You cannot stop the installation after it starts.



**Figure 3-5: InstallShield Wizard Complete Window**

12. In the InstallShield Wizard Complete window, click **Finish** to complete the installation. Then proceed to [Chapter 5, Quick Tour](#) for a description of the Navigator 2 interface.
13. Proceed to [Chapter 4, Starting Navigator 2](#) for instructions about logging in to Navigator 2.

If your Navigator 2 installation fails, see [If the Installation Fails on a Windows Operating System](#).

## **If the installation fails on a Windows operating system**

Data Execution Prevention (DEP) is a Windows security feature intended to prevent an application or service from executing code from a non-executable memory region. DEP perform checks on memory to prevent malicious code or exploits from running on the system by shut down the process once detected. However, DEP can accidentally shut down legitimate processes, like your Navigator 2 installation.

If your management console runs Windows Server 2003 SP1 or Windows XP SP2 or later, and your Navigator 2 installation fails, disable DEP.

1. Click **Start**, and then click **Control Panel**.
2. Click **System**.
3. In the System Properties window, click the **Advanced** tab.
4. In the **Performance** area, click **Settings** and then click the **Data Execution Prevention** tab.

5. Click **Turn on DEP for all programs and services except those I select**.
6. Click **Add** and specify the Navigator 2 installer `HSNM2-xxxx-W-GUI.exe`, where `xxxx` varies with the version of Navigator 2. The Navigator 2 installer `HSNM2-xxxx-W-GUI.exe` is added to the list.
7. Click the checkbox next to the Navigator 2 installer `HSNM2-xxxx-W-GUI.exe` and click **OK**.

## Installing Navigator 2 on a Sun Solaris operating system

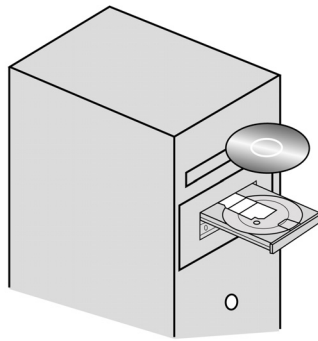
The following procedure describes how to install Navigator 2 on a Navigator 2-supported version of Sun Solaris. Before you perform the following procedure, be sure that the following directories have at least the minimum of amount of available disk space shown in [Table 3-1](#).

**Table 3-1: Solaris Directories and Disk Space**

Directory	Minimum Available Disk Space Required
/opt/HiCommand	1.5 GB
/var/opt/HiCommand	1.0 GB
/var/tmp	1.0 GB

To perform a new installation for Sun Solaris:

1. Insert the Hitachi Storage Navigator Modular 2 installation CD-ROM into the management console's CD/DVD-ROM drive as shown in [Figure 3-6](#).



**Figure 3-6: Management Console CD/DVD Drive**



**NOTE:** If the CD-ROM cannot be read, copy the files `install-hsnm2.sh` and `HSNM2-XXXX-S-GUI.tar.gz` to a file system that the host can recognize.

2. Mount the CD-ROM on the file system. The mount destination is `/cdrom`.
3. Create a temporary directory with sufficient free space (more than 600 MB) on the file system and expand the compressed files. The temporary directory is `/temporary` here.
4. In the console, issue the following command lines. In the last command, `XXXX` varies with the version of Navigator 2.

```
mkdir /temporary
cd /temporary
gunzip < /cdrom/HSNM2-XXXX-S-GUI.tar.gz | tar xf -
```

5. In the console, issue the following command line:

```
/temporary/install-hsnm2.sh -a [IP address] -p [port number]
```

In this command line:

- *[IP address]* is the IP address used to access Navigator 2 from your browser. When entering an IP address, do not specify 127.0.0.1 and localhost. For DHCP environments, specify the host name (computer name).
- *[port number]* is the port number used to access Navigator 2 from your browser. The default, port number is 1099. If you use it, you can omit the `-p` option from the command line.



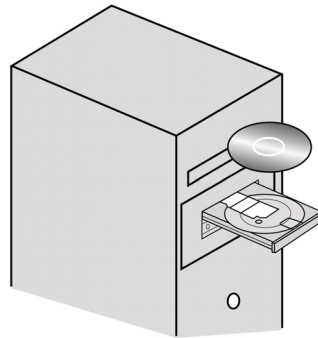
**TIP:** For environments using DHCP, enter the host name (computer name) for the IP address.

- 
6. Proceed to [Chapter 4, Starting Navigator 2](#) for instructions about logging in to Navigator 2.

## Installing Navigator 2 on a Red Hat Linux operating system

To install Navigator 2 on a Navigator 2-supported version of Red Hat Linux, perform the following procedure.

1. Insert the Hitachi Storage Navigator Modular 2 installation CD-ROM into the management console's CD/DVD-ROM drive.



**NOTE:** If the CD-ROM cannot be read, copy the files `install-hsnm2.sh` and `HSNM2-XXXX-L-GUI.rpm` to a file system that the host can recognize.

2. Mount the CD-ROM on the file system. The mount destination is `/cdrom`.
3. In the console, issue the following command line:

```
sh /cdrom/install-hsnm2.sh -a [IP address] -p [port number]
```

In this command line:

- [*IP address*] is the IP address used to access Navigator 2 from your browser. When entering an IP address, do not specify 127.0.0.1 and localhost. For DHCP environments, specify the host name (computer name).
  - [*port number*] is the port number used to access Navigator 2 from your browser. The default port number is 1099. If you use it, you can omit the `-p` option from the command line.
4. Proceed to [Chapter 4, Starting Navigator 2](#) for instructions about logging in to Navigator 2.

## Starting Navigator 2

After you use the instructions in [Chapter 3, Installing Navigator 2](#) to install the Navigator 2 software, use the instructions in this chapter to start Navigator 2.

The topics covered in this chapter are:

- [Hardware considerations](#)
- [Logging in to Navigator 2](#)
- [Selecting a storage system for the first time](#)
- [Running the backup volume wizard](#)

## Hardware considerations

Before you log in to Navigator 2, observe the considerations detailed in the sections that follow.

### Verifying your hardware installation

Install your Hitachi Data Systems storage system according to the instructions in the system's hardware guide. Then verify that your Hitachi Data Systems storage system is operating properly.

### Connecting the management console

After verifying that your Hitachi Data Systems storage system is operational, connect the management console on which you installed Navigator 2 to the storage system's management port(s).

Every controller on a Hitachi storage system has a 10/100BaseT Ethernet management port labeled **LAN**. Hitachi storage systems equipped with two controllers have two management ports, one for each controller. The management ports let you configure the controllers using an attached management console and the Navigator 2 software.

Your management console can connect to the management ports directly using an Ethernet cable or through an Ethernet switch or hub. The management ports support Auto-Medium Dependent Interface/Medium Dependent Interface Crossover (Auto-MDI/MDIX) technology, allowing you to use either standard (straight-through) or crossover Ethernet cables.



**TIP:** You can attach a portable ("pocket") hub between the management console and storage system to configure both controllers in one procedure, similar to using a switch.

---

Use one of these methods to connect the management console to controller, then power up the storage system.

## Logging in to Navigator 2

The following procedure describes how to log in to Navigator 2. When logging in, you can specify an IPv4 address or IPv6 address using a nonsecure (http) or secure (https) connection to the Hitachi storage system.

1. Launch a Web browser on the management console.
2. In the browser's address bar, enter the IP address of the storage system's management port using IPv4 or IPv6 notation. You recorded this IP address in [Table C-1 on page C-2](#):
  - IPv4 http example:  
<http://IP address:23015/StorageNavigatorModular/Login>
  - IPv4 https example:  
<https://IP address:23016/StorageNavigatorModular/Login>
  - IPv6 https example (IP address must be entered in brackets):  
[https://\[IP address\]:23015/StorageNavigatorModular/Login](https://[IP address]:23015/StorageNavigatorModular/Login)

You cannot make a secure connection immediately after installing Navigator 2. To connect using https, set the server certificate and private key (see [Setting the certificate and private key on page 10-8](#)).

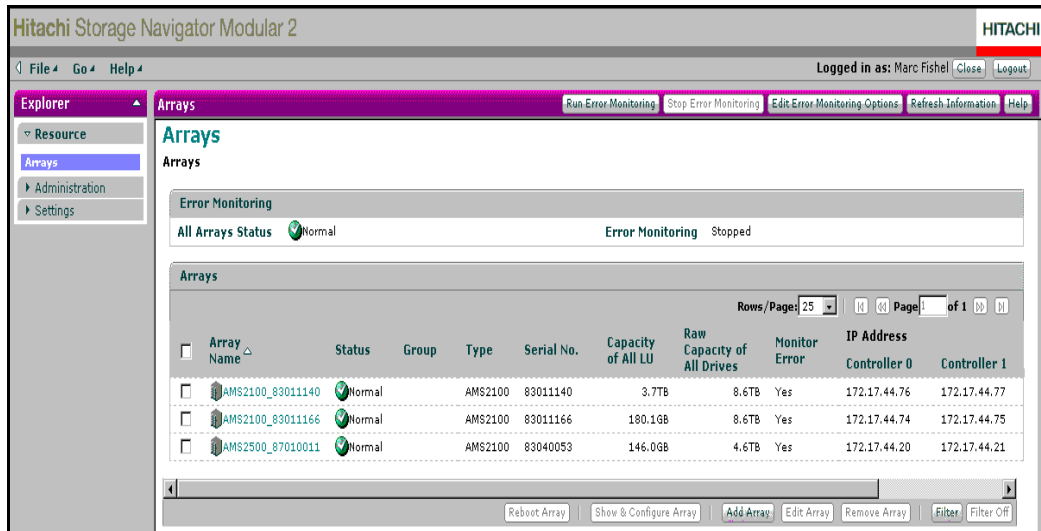
3. At the login page (see [Figure 4-1](#)), type **system** as the default User ID and **manager** as the default case-sensitive password.



**NOTE:** Do not type a loopback address such as **localhost** or 127.0.0.1; otherwise, the Web window appears, but the window following it does not.

**Figure 4-1: Login Page**

4. Click **Login**. Navigator 2 starts and the Arrays window appears, with a list of Hitachi storage systems (see [Figure 4-2 on page 4-4](#)).



**Figure 4-2: Example of Storage Systems in the Arrays Window**

5. Under **Array Name**, click the name of the storage system you want to manage. One of the following actions occurs:
  - If the storage system has not been configured using Navigator 2, a series of first-time setup wizards launch, starting with the Add Array wizard. See [Selecting a storage system for the first time](#), below.
  - Otherwise, the storage system uses the configuration settings previously defined. Proceed to [Chapter 5, Quick Tour](#).



**NOTE:** If no activity occurs during a Navigator 2 session for 20 minutes, the session ends automatically.

## Selecting a storage system for the first time

With primary goals of simplicity and ease-of-use, Navigator 2 has been designed to make things obvious for new users from the get-go. To that end, Navigator 2 runs a series of first-time setup wizards that let you define the initial configuration settings for Hitachi storage systems. Configuration is as easy as pointing and clicking your mouse.

The following first-time setup wizards run automatically when you select a storage system from the Arrays window. Use these wizards to define the basic configuration for a Hitachi storage system.

- Add Array wizard - lets you add Hitachi storage systems to the Navigator 2 database. See [Running the Add Array wizard](#).
- Initial (Array) Setup wizard - lets you configure e-mail alerts, management ports, Internet Small Computer Systems Interface (iSCSI) ports and setting the date and time. See [Running the Initial \(Array\) Setup wizard](#).

- Create & Map Volume wizard - lets you create a logical unit and map it to a Fibre Channel or iSCSI target. See [Running the Create & Map Volume wizard](#).

After you use these wizards to define the initial settings for your Hitachi storage system, you can use Navigator 2 to change the settings in the future if necessary.

Navigator 2 also provides the following wizard, which you can run manually to further configure your Hitachi storage system:

- Backup Volume wizard - lets you create a local backup of a volume. See [page 4-19](#).

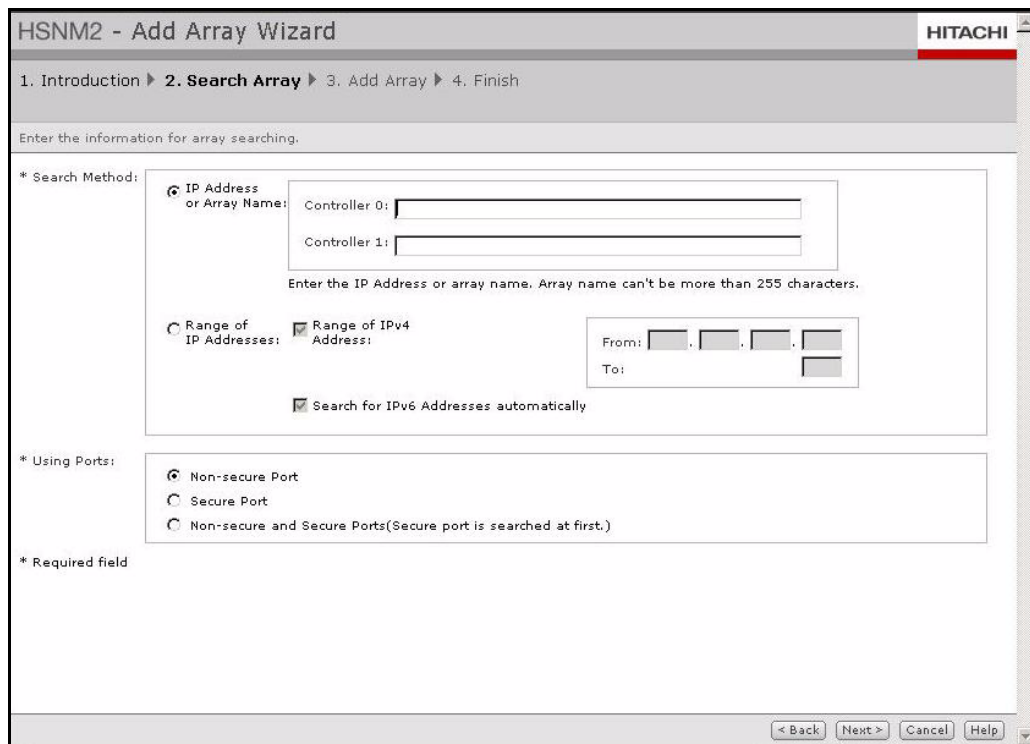
## Running the Add Array wizard

When Navigator 2 launches, it searches its database for registered Hitachi storage systems. At initial login, there are no storage systems in the database, so Navigator 2 searches your storage network for Hitachi storage systems and lets you choose the ones you want to manage.

You can have Navigator 2 discover a storage system by specifying the system's IP address or host name if you know it. Otherwise, you can specify a range of IP addresses. Options let you expand the search to include IPv4 and IPv6 addresses. When Navigator discovers storage systems, it displays them under **Search Results**. To manage one, click to the left of its name and click **Next** to add it and display the Add Array window. Click **Finish** to complete the procedure.

You can also run the Add Array wizard manually to add storage systems after initial log in by clicking **Add Array** at the bottom of the Arrays window.

Initially, an introduction page lists the tasks you complete using this wizard. Click **Next >** to continue to the Search Array window (see [Figure 4-3 on page 4-6](#)) to begin the configuration. [Table 4-1 on page 4-6](#) describes the fields in the Search Array window. As you specify your settings, record them in [Appendix C, Recording Navigator 2 Settings](#) for future reference. Use the navigation buttons at the bottom of each window to move forward or backward, cancel the wizard, and obtain online help.



**Figure 4-3: Add Array Wizard - Search Array Window**

**Table 4-1: Add Array Wizard - Search Array Window**

Field	Description
IP Address or Array Name	Discovers storage systems using a specific IP address or storage system name in the Controller 0 and 1 fields. The default IP addresses are: <ul style="list-style-type: none"> <li>Controller 0: 192.168.0.16</li> <li>Controller 1: 192.168.0.17</li> </ul> For directly connected consoles, enter the default IP address just for the port to which you are connected; you will configure the other controller later.
Range of IP Addresses	Discovers storage systems using a starting ( <b>From</b> ) and ending ( <b>To</b> ) range of IP addresses. Check <b>Range of IPv4 Address</b> and/or <b>Search for IPv6 Addressees automatically</b> to widen the search if desired.
Using Ports	Select whether communications between the console and management ports will be secure, nonsecure, or both.

## Running the Initial (Array) Setup wizard

After you complete the Add Array wizard at initial log in, the Initial (Array) Setup wizard starts automatically.

Using this wizard, you can configure:

- E-mail alerts — see [Initial Array \(Setup\) wizard — configuring email alerts](#)
- Management ports — see [Initial Array \(Setup\) wizard — configuring management ports](#)
- Host ports — see [Initial Array \(Setup\) wizard — configuring host ports](#)
- Spare drives — see [Initial Array \(Setup\) wizard — configuring spare drives](#)
- System date and time — see [Initial Array \(Setup\) wizard — configuring the system date and time](#)

Initially, an introduction page lists the tasks you complete using this wizard. Click **Next >** to continue to the Search Array window (see [Figure 4-4 on page 4-8](#) and [Table 4-2 on page 4-8](#)) and begin the configuration. Use the navigation buttons at the bottom of each window to move forward or backward, cancel the wizard, and obtain online help.

The following sections describe the Initial (Array) Setup wizard windows.



**NOTE:** To change these settings in the future, run the wizard manually by clicking the name of a storage system under the **Array Name** column in the Arrays window and then clicking **Initial Setup** in the **Common Array Tasks** menu.

---

## Initial Array (Setup) wizard — configuring email alerts

The Set up E-mail Alert window is the first window in the Initial (Setup) Array wizard. Using this window, you can configure the storage system to send email notifications if an error occurs. By default, email notifications are disabled. To accept this setting, click **Next** and skip to [Initial Array \(Setup\) wizard — configuring management ports on page 4-9](#).

To enable email alerts:

1. Complete the fields in [Figure 4-4](#) (see [Table 4-2](#)).
2. Click **Next** and go to [Initial Array \(Setup\) wizard — configuring management ports on page 4-9](#).



**NOTE:** This procedure assumes your Simple Mail Transfer Protocol (SMTP) server is set up correctly to handle email. If desired, you can send a test message to confirm that email notifications will work.

**Figure 4-4: Set up E-mail Alert Page**

**Table 4-2: Enabling Email Notifications**

Field	Description
E-mail Error Report Disable / Enable	To enable email notifications, click Enable and complete the remaining fields.
Domain Name	Domain appended to addresses that do not contain one.
Mail Server Address	Email address or IP address that identifies the storage system as the source of the email.
From Address	Each email sent by the storage system will be identified as being sent from this address.
Send to Address	Up to 3 individual email addresses or distribution lists where notifications will be sent.
Reply To Address	Email address where replies can be sent.

## Initial Array (Setup) wizard — configuring management ports

The Set up Management Ports window lets you configure the management ports on the Hitachi storage system. These are the ports you use to manage the system using Navigator 2.

To configure the management ports:

1. Complete the fields in [Figure 4-5](#) (see [Table 4-3](#)).
2. Click **Next** and go to [Initial Array \(Setup\) wizard — configuring host ports on page 4-10](#).



**NOTE:** If your management console is directly connected to a management port on one controller, enter settings for that controller only (you will configure the management port on the other controller later). If your console is connected via a switch or hub, enter settings for both controllers now.

**Figure 4-5: Set up Management Ports Window**

**Table 4-3: Set up Management Ports Window**

Field	Description
IPv4/IPv6	Select the IP addressing method you want to use. For more information about IPv6, see <a href="#">Using Internet Protocol Version 6 on page 10-2</a> .
Use DHCP	Configures the management port automatically, but requires a Dynamic Host Control Protocol (DHCP) server. IPv6 users: note that IPv6 addresses are based on Ethernet addresses. If you replace the storage system, the IP address changes. Therefore, you can want to assign static IP addresses to the storage system using the Set Manually option instead of having them auto-assigned by a DHCP server.

**Table 4-3: Set up Management Ports Window (Continued)**

Field	Description
Set Manually	Lets you complete the remaining fields to configure the management port manually.
IPv4 Address	Static Internet Protocol address that matches the subnet where the storage system will be used.
IPv4 Subnet Mask	Subnet mask that matches the subnet where the storage system will be used.
IPv4 Default Gateway	Default gateway that matches the gateway where the storage system will be used.
Negotiation	Use the default setting ( <b>Auto</b> ) to auto-negotiate speed and duplex mode, or select a fixed speed/duplex combination.

### **Initial Array (Setup) wizard — configuring host ports**

The Set up Host Ports window lets you configure the host data ports on the Hitachi storage system. The fields in this window vary, depending on whether the host ports on the Hitachi storage system are Fibre Channel or iSCSI.

1. Perform one of the following steps:
  - To configure the Fibre Channel host ports, complete the fields in [Figure 4-6 on page 4-11](#) (see [Table 4-4 on page 4-11](#)).
  - To configure iSCSI host ports, complete the fields in [Figure 4-5 on page 4-9](#) (see [Table 4-5 on page 4-12](#)).
2. Click **Next** and go to [Initial Array \(Setup\) wizard — configuring spare drives on page 4-13](#).

HSNM2 - Setup Array Wizard HITACHI

1. Introduction ▶ 2. Set up E-mail Alert ▶ 3. Set up Management Ports ▶ **4. Set up Host Ports** ▶ 5. Set up Spare Drive ▶ 6. Set up Date & Time ▶ 7. Confirm ▶ 8. Finish

Enter the information for the host ports.

FC Ports		FC Ports	
* Port Address:	0000EF	* Port Address:	0000EF
<b>Port0A</b> * Transfer Rate:	Auto	<b>Port1A</b> * Transfer Rate:	Auto
* Topology:	Point-to-Point	* Topology:	Point-to-Point
-----		-----	
* Port Address:	0000EF	* Port Address:	0000EF
<b>Port0B</b> * Transfer Rate:	Auto	<b>Port1B</b> * Transfer Rate:	Auto
* Topology:	Loop	* Topology:	Loop

\* Required field

< Back Next > Cancel Help

**Figure 4-6: Set up Host Ports Window for Fibre Channel Host Ports**

**Table 4-4: Set up Host Ports Window for Fibre Channel Host Ports**

Field	Description
Port Address	Enter the address for the Fibre Channel ports.
Transfer Rate	Select a fixed data transfer rate from the drop-down list that corresponds to the maximum transfer rate supported by the device connected to the storage system, such as the server or switch.
Topology	Select the topology in which the port will participate: <ul style="list-style-type: none"> <li>Point-to-Point = port will be used with a Fibre Channel switch.</li> <li>Loop = port is directly connected to the Fibre Channel port of an HBA installed in a server.</li> </ul>

HSNM2 - Initial Setup Wizard HITACHI

1. Introduction ▶ 2. Set up E-mail Alert ▶ 3. Set up Management Ports ▶ **4. Set up Host Ports** ▶ 5. Set up Date & Time ▶ 6. Confirm ▶ 7. Finish

Enter the information for the host ports.

iSCSI Ports		
Controller 0	Port 0A	* IP Address: <input type="text" value="192.168.0.200"/>
		* Subnet Mask: <input type="text" value="255.255.255.0"/>
		* Default Gateway: <input type="text" value="0.0.0.0"/>
Controller 1	Port 0B	* IP Address: <input type="text" value="192.168.0.201"/>
		* Subnet Mask: <input type="text" value="255.255.255.0"/>
		* Default Gateway: <input type="text" value="0.0.0.0"/>
Controller 1	Port 1A	* IP Address: <input type="text" value="192.168.0.208"/>
		* Subnet Mask: <input type="text" value="255.255.255.0"/>
		* Default Gateway: <input type="text" value="0.0.0.0"/>
Controller 1	Port 1B	* IP Address: <input type="text" value="192.168.0.209"/>
		* Subnet Mask: <input type="text" value="255.255.255.0"/>
		* Default Gateway: <input type="text" value="0.0.0.0"/>

\* Required field

< Back Next > Cancel Help

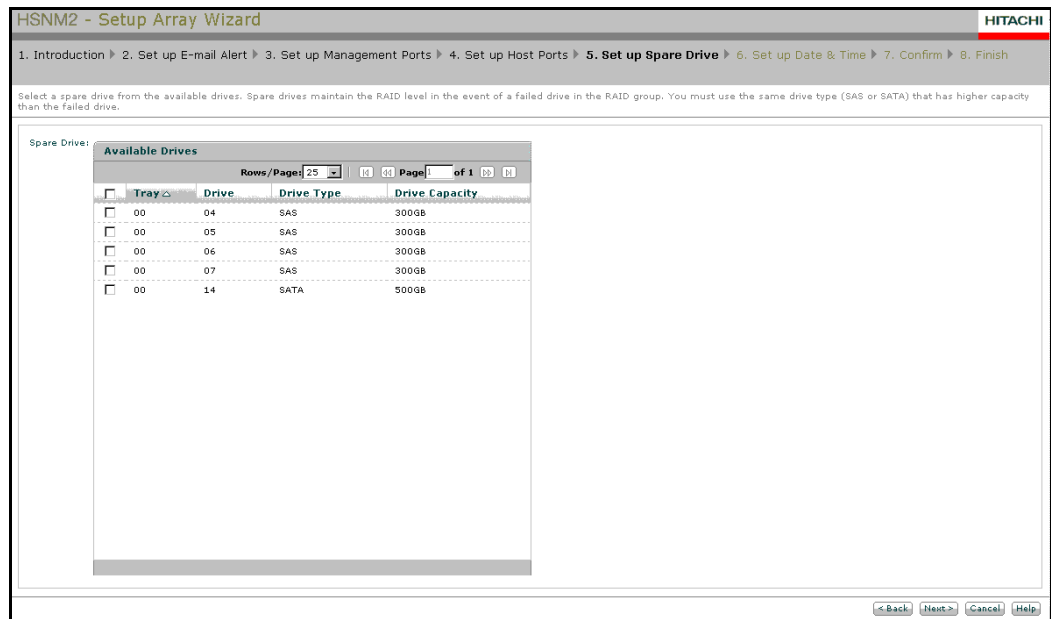
**Figure 4-7: Set up Host Ports Window for iSCSI Host Ports**

**Table 4-5: Set up Host Ports Window for iSCSI Host Ports**

Field	Description
IP Address	Enter the IP address for the storage system iSCSI host ports. The default IP addresses are: Controller 0, Port A: 192.168.0.200 Controller 0, Port B: 192.168.0.201 Controller 1, Port A: 192.168.0.208 Controller 1, Port B: 192.168.0.209
Subnet Mask	Enter the subnet mask for the storage system iSCSI host port.
Default Gateway	If a router is required for the storage system host port to reach the initiator(s), the default gateway must have the IP address of that router. In a network that requires a router between the storage system and the initiator, enter the router's IP address. In a network that uses only direct connection, or a switch between the storage system and the initiator(s), no entry is required.

## Initial Array (Setup) wizard — configuring spare drives

Using the Set up Spare Drive window, you can select a spare drive from the available drives. If a drive in a RAID group fails, the Hitachi storage system automatically uses the spare drive you select here. The spare drive must be the same type, for example, Serial Attached Technology Attachment (SATA), Serial Attached SCSI (SAS), or Solid State Disk (SSD), as the failed drive and have the same capacity as or higher capacity than the failed drive. When you finish, click **Next** and go to [Initial Array \(Setup\) wizard — configuring the system date and time on page 4-13](#).



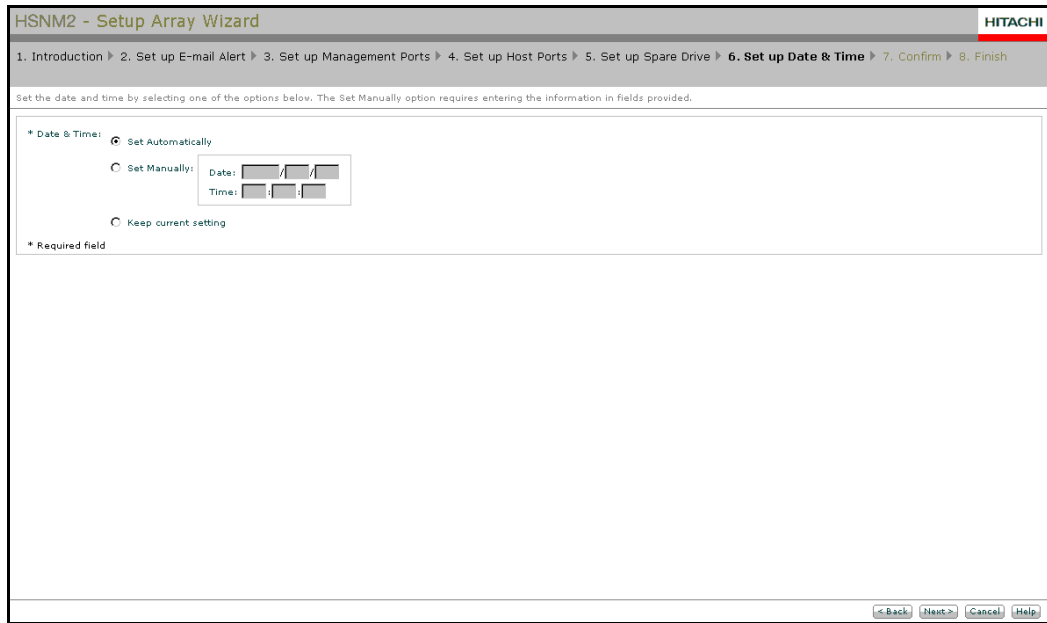
**Figure 4-8: Initial Array (Setup) Wizard: Set up Spare Drive Window**

## Initial Array (Setup) wizard — configuring the system date and time

Using the Set up Date & Time window, you can select whether the Hitachi storage system date and time are to be set automatically, manually, or not at all. If you select **Set Manually**, enter the date and time (in 24-hour format) in the fields provided. When you finish, click **Next**.

## Initial Array (Setup) wizard — confirming your settings

Use the remaining windows to confirm your settings. As you confirm your settings, record them in [Appendix C, Recording Navigator 2 Settings](#) for future reference. To change a setting, click **Back** until you reach the desired window, change the setting, and click **Next** until you return to the appropriate confirmation window. At the final Confirm window, click **Confirm** to commit your settings. At the Finish window, click **Finish** and go to [Running the Create & Map Volume wizard on page 4-14](#).



**Figure 4-9: Set up Date & Time Window**

## Running the Create & Map Volume wizard

After you complete the Initial (Array) Setup wizard, the Create & Map Volume wizard starts automatically. Using this wizard, you can create or select RAID groups, logical units, and host groups.

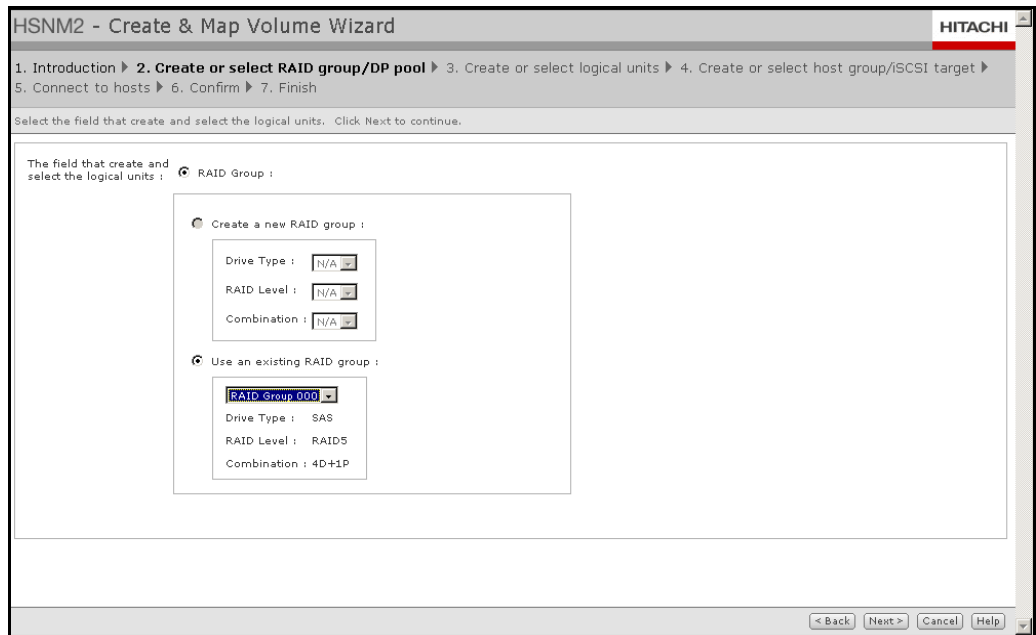
Initially, an introduction page lists the tasks that can be completed by this wizard. Click **Next >** to continue to the Search RAID Group window (see [Figure 4-10 on page 4-15](#)) and begin the configuration. Use the navigation buttons at the bottom of each window to move forward or backward, cancel the wizard, and obtain online help.



**NOTE:** To change these settings in the future, run the wizard manually by clicking the storage system in the Arrays window, and then clicking **Create Logical Unit and Mapping** in the **Common Array Tasks** menu.

## Create & Map Volume wizard — defining RAID groups

Using the Search RAID Group window, create a new RAID group for the Hitachi storage system or make it part of an existing RAID group.



**Figure 4-10: Search RAID Group Window**

To create a new RAID group:

1. Click **Create a New RAID Group**.
2. Use the drop-down lists to select a drive type, RAID level, and data + parity (D+P) combination for the RAID group
3. Click **Next** to continue to the Create or Select logical unit window.

To select an existing RAID group

1. Click **Use an Existing RAID Group**.
2. Select the desired RAID Group from the **RAID Group** drop-down list.
3. Click **Next** and go to [Create & Map Volume wizard — defining logical units](#).

## Create & Map Volume wizard — defining logical units

Using the next window in the Create & Map Volume wizard, you can create new logical units or use existing logical units for the Hitachi storage system.

LUN	Capacity	RAID Group	RAID Level	Drive Type	Assigned to host
0000	10.0GB	000	RAID6(6D+2P)	SAS	No
0001	100.0MB	000	RAID6(6D+2P)	SAS	Yes
0002	60.0MB	000	RAID6(6D+2P)	SAS	Yes
0003	30.0MB	000	RAID6(6D+2P)	SAS	Yes
0004	40.0MB	000	RAID6(6D+2P)	SAS	Yes
0005	50.0MB	000	RAID6(6D+2P)	SAS	Yes

**Figure 4-11: Create or Select Logical Volumes Window**

If you select a RAID group with a capacity less than 10 GB, select from the existing RAID group capacity or create RAID group capacity.

To create new logical units:

1. Click the **Create a new logical units** check box.
2. Perform one of the following steps:
  - Enter the desired **Logical Unit Capacity** and **Number of Logical Units**. Each logical unit that will be created will be the same size that you specify in this field.
  - Click **Create one logical unit to assign one of the maximum free space in the selected RAID group** to create a single logical unit consisting of the maximum available free space in the selected RAID group.
3. Click **Next** and go to [Create & Map Volume wizard — defining host groups or iSCSI targets](#).

To select an existing logical unit:

1. Select one or more logical units under **Existing logical units**.
2. Click **Next** and go to [Create & Map Volume wizard — defining host groups or iSCSI targets](#).

## Create & Map Volume wizard — defining host groups or iSCSI targets

Using the next window in the Create & Map Volume wizard, you can select:

- A physical port for a Fibre Channel host group or iSCSI target.
- Host groups for storage systems with Fibre Channel ports.
- iSCSI targets for storage systems with iSCSI ports.

The screenshot shows the 'Create & Map Volume Wizard' window for HSNM2. The current step is '4. Create or select host group/iSCSI target'. The window contains the following elements:

- Port Selection:** A row of radio buttons labeled 0A through 1H. 0A is selected.
- Host Group Selection:** Two radio buttons: 'Create a new host group' (unselected) and 'Use an existing host group' (selected).
- Form Fields (for 'Create a new host group'):**
  - Host Group No.:** A text box with a range of 'From 1 to 127'.
  - Name:** A text box with a note: '32 characters or less (alphanumeric characters, !, #, \$, %, &, \*, +, -, ., /, :, ;, =, @, ^, \_, {, }, ~, '(', ')', '[, ]' or space).'
  - Platform:** A dropdown menu set to 'not specified'.
  - Middleware:** A dropdown menu set to 'not specified'.
- Form Field (for 'Use an existing host group'):**
  - Host Group:** A dropdown menu set to '000:G000'.
- Navigation:** Buttons for '< Back', 'Next >', 'Cancel', and 'Help' at the bottom right.

**Figure 4-12: Create or Select Host Group/iSCSI Target Window**

To create or select a host group for Fibre Channel storage systems:

1. Next to **Port**, select a physical port.
2. Create a new host group or select an existing one:
  - To create a new host group:
    - a. Click **Create a new host group**.
    - b. Enter a **Host Group No** (from 1 to 127).
    - c. Enter a host group **Name** (up to 32 characters).
    - d. Select **Platform** and **Middleware** settings from the drop-down lists (refer to the Navigator 2 online help).
  - To select an existing host group:
    - a. Click **Use an existing host group**.
    - b. Select a host group from the **Host Group** drop-down list.
3. Click **Next** and go to [Create & Map Volume wizard — connecting to a host on page 4-18](#).

For iSCSI storage systems, create a new iSCSI target or select an existing one:

1. Next to **Port**, select a port to map to from the available ports options.
2. Create a new iSCSI target or select an existing one:

To create a new iSCSI target:

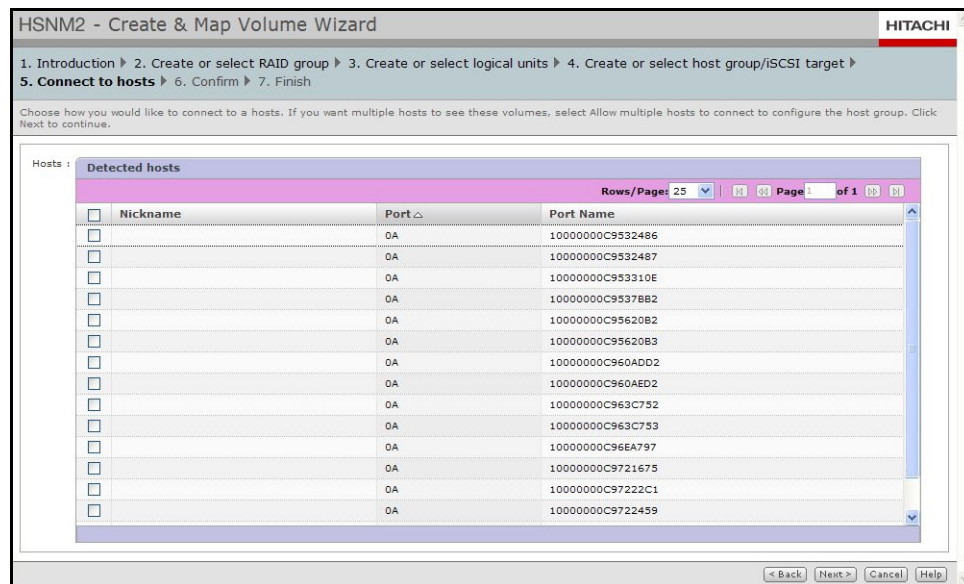
- a. Click **Create a new iSCSI target**.
- b. Enter an **iSCSI Target No** (from 1 to 127).
- c. Enter an iSCSI target **Name** (up to 32 characters).
- d. Select **Platform** and **Middleware** settings from the drop-down lists (refer to the Navigator 2 online help).

To select an existing iSCSI target:

- a. Click **Use an existing iSCSI target**.
  - b. Select an iSCSI target from the **iSCSI Target** drop-down list.
3. Click **Next** and go to [Create & Map Volume wizard — connecting to a host](#), below.

## Create & Map Volume wizard — connecting to a host

If LUN Manager is enabled, the Connect to Hosts window lets you select the hosts to which the Hitachi storage system will be connected. If LUN Manager is not enabled, the wizard skips this window and goes to the first confirm window (see step 4 in the following procedure). The iSCSI target on the storage system will communicate with the iSCSI initiator on the host.



**Figure 4-13: Connect to Hosts Window**

If the Connect to Hosts window appears:

1. To allow multiple hosts to map to the selected volumes, click **Allow multiple hosts**.
2. Check all of the hosts you want to connect to the Hitachi storage system.

3. When you finish, click **Next**.

## Create & Map Volume wizard — confirming your settings

Use the remaining windows to confirm your settings. As you confirm your settings, record them in [Appendix C, Recording Navigator 2 Settings](#) for future reference. To change a setting, click **Back** until you reach the desired window, change the setting, and click **Next** until you return to the appropriate confirmation window. At the final Confirm window, click **Confirm** to commit your settings.

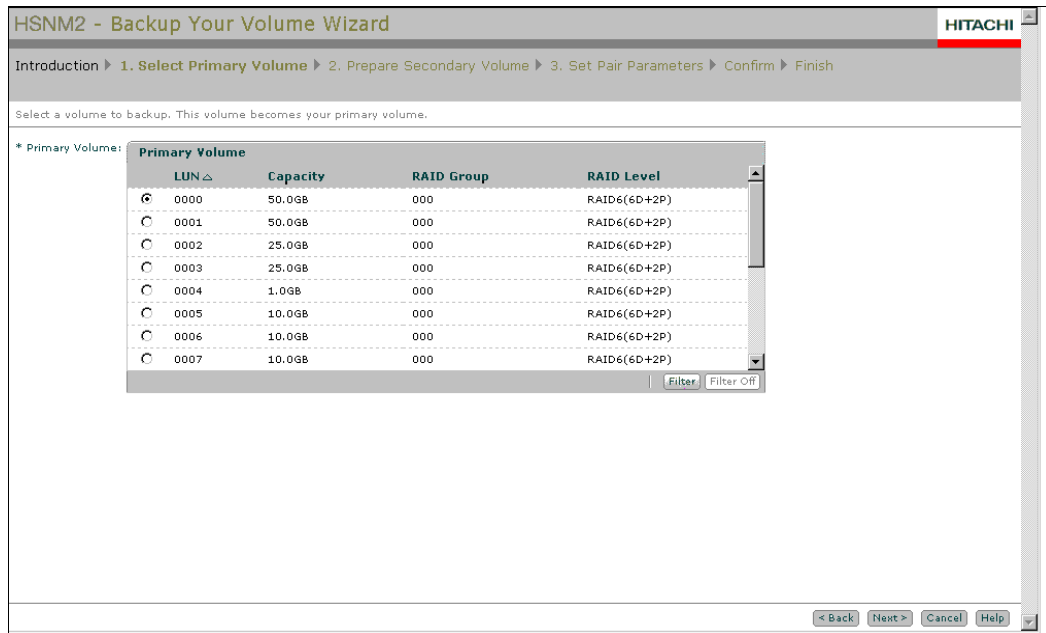
To create additional RAID groups, logical units, and host groups, click **Create & Map More LU** and repeat the wizard starting from the Search RAID Group window. Otherwise, click **Finish** to close the wizard and return to the Array Properties window.

This completes the first-time configuration wizards. If desired, you can run the remaining wizards described in this chapter to further configure your Hitachi storage system.

## Running the backup volume wizard

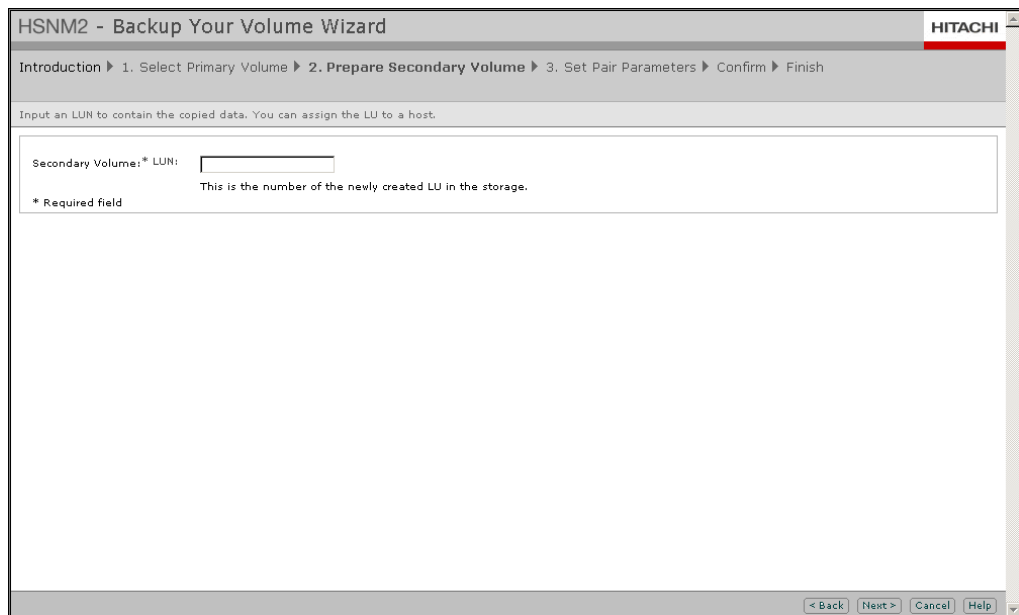
Navigator 2 provides a Backup Volume wizard that lets you create a local backup of a volume. To run this wizard:

1. In the Arrays window, click the name of a storage system under the **Array Name** column.
2. When the **Common Array Tasks** menu appears, click **Backup Volume**. An introduction page lists the tasks that can be completed by this wizard.
3. Click **Next >**.
4. At the Select Primary Volume window (see [Figure 4-14](#)), select the volume that will be copied and click **Next**.



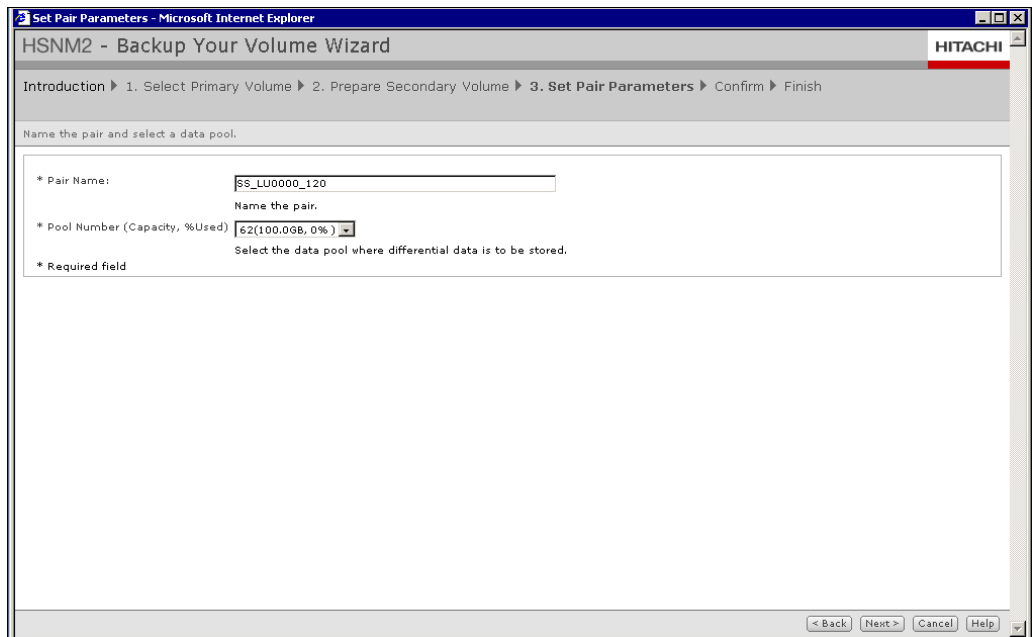
**Figure 4-14: Select Primary Volume Window**

- At the Prepare Secondary Volume window (see [Figure 4-15 on page 4-20](#)), set up the volume to which the data will be copied and click **Next**.



**Figure 4-15: Select Secondary Volume Window**

- At the Set Pair Parameters window, define the settings for the volume pair and click **Next**.



**Figure 4-16: Set Pair Parameters Window**

7. Use the Confirm window to confirm your settings. As you confirm your settings, record them in [Appendix C, Recording Navigator 2 Settings](#) for future reference. To change a setting, click **Back** until you reach the desired window, change the setting, and click **Next** until you return to the Confirm window. After confirming your settings, click **Confirm** to commit your settings.
8. At the Finish window, click **Finish**.



## Quick Tour

Navigator 2 provides an intuitive user interface for configuring and managing Hitachi storage systems. This chapter provides a quick tour of the Navigator 2 interface and then summarizes the configuration and management activities you can perform using Navigator 2.

The topics covered in this chapter are:

- ❑ [Understanding the Navigator 2 interface](#)
- ❑ [Performing Navigator 2 activities](#)
- ❑ [Description of Navigator 2 activities](#)

# Understanding the Navigator 2 interface

Figure 5-1 shows the Navigator 2 interface with the Arrays window displayed. This window appears when you log in to Navigator 2. It also appears when you click **Arrays** in the Explorer panel.

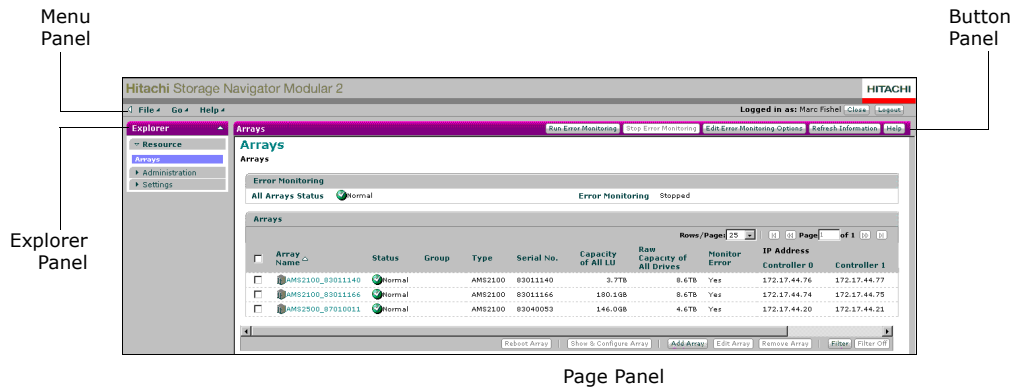


Figure 5-1: Navigator 2 Interface

## Menu Panel

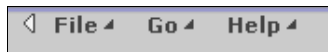


Figure 5-2: Menu Panel

The Menu Panel appears on the left side of the Navigator 2 user interface.

The Menu Panel always contains the following menus, regardless of the window displayed in the Page Panel:

- **File** — contains commands for closing the Navigator 2 application or logging out. These commands are functionally equivalent to the **Close** and **Logout** buttons in the Button Panel, described on the next page.
- **Go** — lets you start the ACE tool, a utility for configuring older AMS 1000 family systems.
- **Help** — displays the Navigator 2 online help and version information.

## Explorer Panel

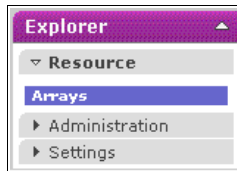


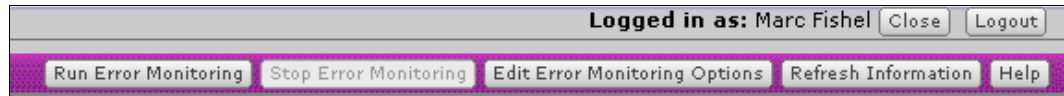
Figure 5-3: Explorer Panel

The Explorer Panel appears below the Menu Panel. The Explorer Panel displays the following commands, regardless of the window shown in the Page Panel.

- **Resource** — contains the **Arrays** command for displaying the Arrays window.

- **Administration** — contains commands for accessing users, permissions, and security settings. We recommend you use **Administration > Security > Password > Edit Settings** to change the default password after you log in for the first time. See [Changing the default system password on page 6-6](#).
- **Settings** — lets you access user profile settings.

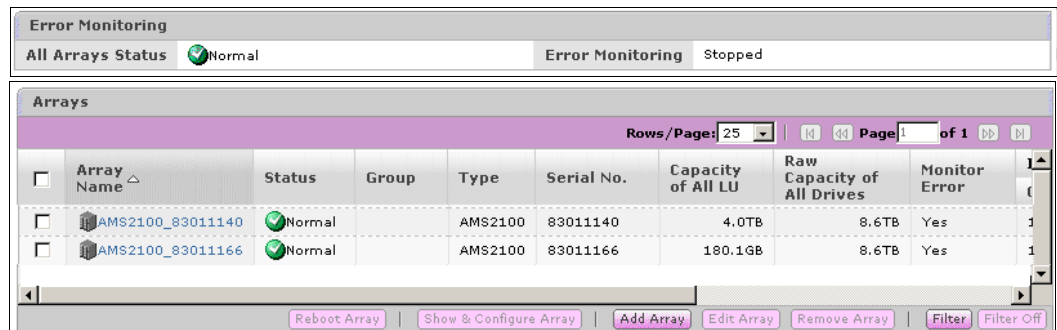
## Button panel



The Button Panel appears on the right side of the Navigator 2 interface and contains two rows of buttons:

- Buttons on the top row let you close or log out of Navigator 2. These buttons are functionally equivalent to the **Close** and **Logout** commands in the **File** menu, described on the previous page.
- Buttons on the second row change, according to the window displayed in the Page Panel. In the example above, the buttons on the second row appear when the Arrays window appears in the Page Panel.

## Page panel



The Page Panel is the large area below the Button Panel. When you click an item in the Explorer Panel or the Arrays Panel (described later in this chapter), the window associated with the item you clicked appears in the Page Panel.

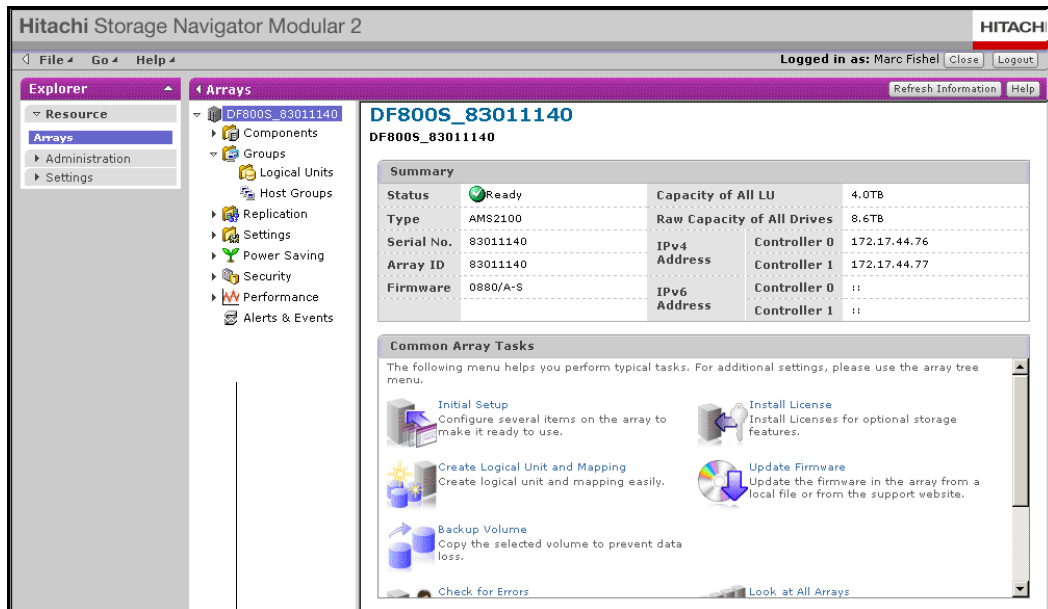
Information can appear at the top of the Page Panel and buttons can appear at the bottom for performing tasks associated with the window in the Page Panel. When the Arrays window in the example above is shown, for example:

- Error monitoring information appears at the top of the Page Panel.
- Buttons at the bottom of the Page Panel let you reboot, show and configure, add, edit, remove, and filter Hitachi storage systems.

## Performing Navigator 2 activities

To start performing Navigator activities, you click a Hitachi storage system on the Arrays window. When you click a storage system, an Arrays Panel appears between the Explorer Panel and Page Panel (see [Figure 5-4 on](#)

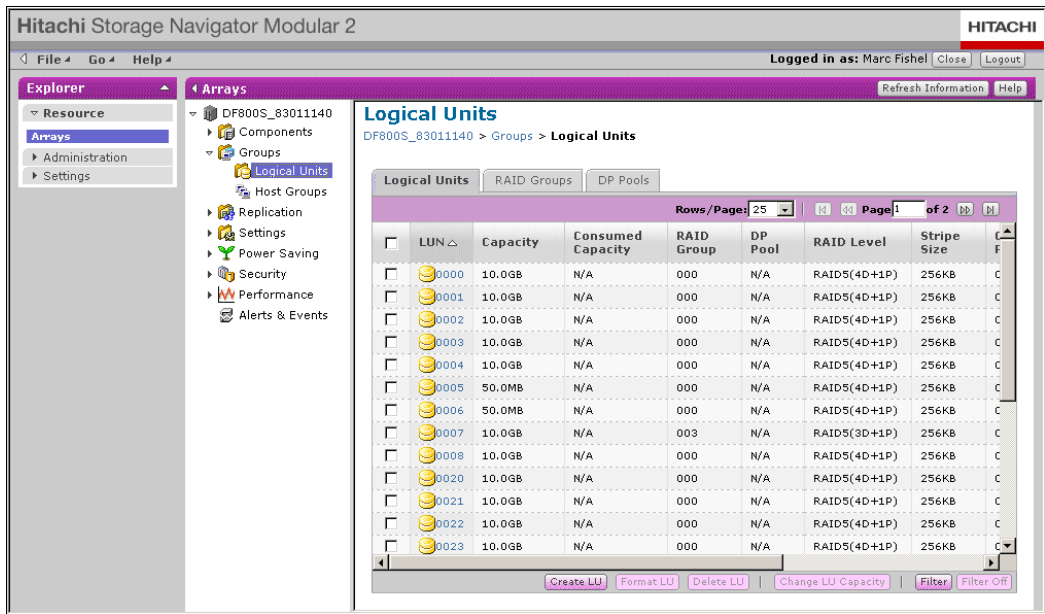
page 5-4). At the top of the Arrays Panel are the type and serial number of the storage system you selected to be managed from the Arrays window. If you click the type and serial number, common storage system tasks appear in the Page Panel.



Arrays Panel

**Figure 5-4: Arrays Panel**

If you click a command in the Arrays Panel, the Page Panel shows the corresponding page or the Arrays Panel reveals a list of subcommands for you to click. In [Figure 5-4](#), for example, clicking **Groups** reveals two subcommands, **Logical Groups** and **Host Groups**. If you select either subcommand, the appropriate information appears in the Page Panel. [Figure 5-5](#) shows an example of how the Arrays Panel and Page Panel look after clicking **Logical Units** in the Arrays Panel.



**Figure 5-5: Example of Logical Unit Information**

## Description of Navigator 2 activities

You use the Arrays Panel and Page Panel to manage and configure Hitachi storage systems. [Table 5-1](#) summarizes the Navigator 2 activities you can perform, and the commands and subcommands you click in the Arrays Pane to perform them.

This document describes how to perform key Navigator 2 activities. If an activity is not covered in this document, please refer to the Navigator online help. To access the help, click the **Help** button in the Navigator 2 Menu Panel (see [Menu Panel on page 5-2](#)).

**Table 5-1: Description of Navigator 2 Activities**

Arrays Pane	Description
Components	displays a page for accessing controllers, caches, interface boards, host connector, batteries, and trays, as described below.
Components > Controllers	Lists each controller in the Hitachi storage system and the controller's status.
Components > Caches	Shows the status, capacity, and controller associated with the cache in the Hitachi storage system.
Components > Interface Boards	Shows status information about each interface board in the Hitachi storage system and its corresponding controller.
Components > Host Connectors	Shows the host connector and port ID, status, controller number, and type of host connector (for example, Fibre Channel) for each host connector in the Hitachi storage system.

**Table 5-1: Description of Navigator 2 Activities (Continued)**

Arrays Pane	Description
Components > Batteries	Shows the batteries in the Hitachi storage system and their status.
Components > Trays	Shows the status, type, and serial number of the tray. The serial number is the same as the serial number of the Hitachi storage system.
Groups — displays a page for accessing logical units and host groups, as described below.	
Groups > Logical Units	Shows the logical units, RAID groups, and Dynamic Provisioning pools defined for the Hitachi storage system. For information about Dynamic Provisioning, refer to the <i>Hitachi AMS 2000 Family Dynamic Provisioning Configuration Guide (MK-09DF8201)</i> .
Groups > Host Groups	Lets you: <ul style="list-style-type: none"> <li>• Create or edit host groups.</li> <li>• Enable host group port-level security.</li> <li>• Change or delete the WWNs and WWN nicknames.</li> </ul>
Replication — displays a page for accessing local replication, remote replication, and setup parameters, as described below.	
Replication > Local Replication	Lets you create a copy of a volume in the storage system using: <ul style="list-style-type: none"> <li>• ShadowImage to create a duplicate copy of a volume.</li> <li>• Copy on Write Snapshot to create a virtual point-in-time copy of a volume.</li> </ul>
Replication > Remote Replication	Lets you back up information using TrueCopy remote replication and TrueCopy Extended Distance to create a copy of a volume (logical unit) in the Hitachi storage system.
Replication > Setup	Assists you in setting up components of both local and remote replication.
Settings — displays a page for accessing FC settings, spare drives, licenses, command devices, DMLU, volume migration, LAN settings, firmware version, email alerts, date and time, and advanced settings.	
Settings > FC Settings	Shows the Fibre Channel ports available on the Hitachi storage system and provides updated Transfer Rate, Topology, and Link Status information.
Settings > Spare Drives	Lets you select a spare drive from a list of assignable drives.
Settings > Licenses	Lets you enable licenses for Storage Features that require them.
Settings > Command Devices	Lets you add, change, and remove command devices (and their logical units and RAID manager protection setting) for Hitachi storage systems.

**Table 5-1: Description of Navigator 2 Activities (Continued)**

<b>Arrays Pane</b>	<b>Description</b>
Settings > DMLU	Lets maintenance technicians and qualified users add and remove differential management logical units (DMLUs). DMLUS are logical units that consistently maintain the differences between two logical units: P-VOLS and S-VOLS.
Settings > Volume Migration	Lets you migrate data to other disk areas.
Settings > LAN	Shows user management port, maintenance port, port number and security (secure LAN) information about the Hitachi storage system being managed.
Settings > Firmware	Shows the firmware version installed on the Hitachi storage system and lets you upgrade the firmware.
Settings > Email Alert	Lets you configure the Hitachi storage system to send email alerts if a failure occurs.
Settings > Date & Time	Lets you set the Hitachi storage system date, time, timezone, and up to two NTP server settings.
Settings > Advanced Settings	Lets you access features available in Storage Navigator Modular.
Power Savings — displays a page for accessing RAID group power saving settings.	
Power Savings > RG Power Saving	Lets you control which RAID groups are in spin-up or spin-down mode to conserve power.
Security — displays a page for accessing Secure LAN and Account Authentication settings, as described below.	
Security > Secure LAN	Lets you view and refresh SSL certificates.
Security > Audit Logging	Lets you enable audit to collect Hitachi storage system event information and output the information to a configured Syslog server.
Performance — displays a page for monitoring the Hitachi storage system, configuring tuning parameters, and viewing DP pool trend and optimization information, as described below.	
Performance > Monitoring	Lets you monitor a Hitachi storage system's performance (for example, utilization rates of resources in a disk array and loads on the disks and ports) and output the information to a text file.
Performance > Tuning Parameters	Lets you set parameters to tune the Hitachi storage system for optimum performance.

**Table 5-1: Description of Navigator 2 Activities (Continued)**

Arrays Pane	Description
Performance > DP Pool Trend	Lets you view the Dynamic Provisioning pool trend for the Hitachi storage system (for example, utilization rates of DP pools) and output the information to a CSV file. For information about Dynamic Provisioning, refer to the <i>Hitachi AMS 2000 Family Dynamic Provisioning Configuration Guide</i> (MK-09DF8201).
Performance > DP Optimization	Lets you optimize DP optimization priority for the Hitachi storage system by resolving unbalanced conditions, optimizing DP, and reclaiming zero pages.
Alerts & Events — shows Hitachi storage system status, serial number and type, and firmware revision and build date. Also, displays events related to the storage system, including firmware downloads and installations, errors, alert parts, and event log messages.	

# Managing Users, Permissions, and Passwords

Navigator 2 provides an intuitive user interface for configuring and managing access privileges into Hitachi storage systems. This chapter describes how to configure permissions and passwords that enable access to Navigator 2 and the Hitachi storage systems.

The topics covered in this chapter are:

- ❑ [Managing users](#)
- ❑ [Understanding permissions](#)
- ❑ [Changing passwords](#)
- ❑ [Working with user IDs](#)

# Managing users

Before a user can use Navigator 2, an account for that user must be set up and permissions granted for that user. Permissions define the privileges a user has when using Navigator 2.

## Adding users

Users can be created and their permissions can be defined by:

- The System user, which is the built-in account for the Navigator 2
- Users who have been granted User Management/Admin permission

To add a user:

1. In the Administration tree, click **Users and Permissions > Users**. The Users window shows a list of users.
2. Click **Add User**. The Add User window appears.
3. Complete the fields in the window (see [Table 6-1](#)).
4. Click **OK** to save the settings. The user account is created, you return to the Users subwindow, and the new user account appears in the user list.



**NOTE:** The new user cannot access Navigator 2 until you define permissions for that user (see [Understanding permissions on page 6-4](#)).

**Table 6-1: Adding Users**

Field	Description
User ID	ID of the user. This is a required field
Password	Case-sensitive password assigned to this user. This is a required field. The password can be up to 256 bytes long, and can contain only the following characters:  A - Z a - z 0 - 9 ! # \$ % & ' ( ) * + - . = @ \ ^ _    For security, each typed password character appears as an asterisk (*). This is a required field.  Your system administrator might add conditions for the minimum number of characters or combination of characters that can be used as a password. For more information, contact your system administrator.  Note: For HiCommand Suite of products earlier than version 5.5, the number of characters that can be set for a user ID and password is between 4 and 25 bytes. For environments that contain HiCommand Suite products version 5.5 or later and products earlier than version 5.5, set a user ID using between 4 and 25 bytes.
Verify Password	Type the same password you typed in the Password field. This is a required field.

**Table 6-1: Adding Users (Continued)**

Field	Description
Full Name	Entering the user's full name is optional. If you include it, enter no more than 80 Basic Latin characters. Basic Latin characters are the following characters (Unicode 0020 to 007E):  A-Z a-z 0-9 ! " # \$ % & ' ( ) * + , - . / : ; < = > ? @ [ \ ] ^ _ ` {   } ~ (space)  <b>Note:</b> You cannot use two or more dollar signs consecutively (for example, \$\$ or \$\$\$). The full name appears in the global task bar area after a user logs in. If this item is omitted, the user ID will be displayed in the global task bar area.
E-mail Address	Type the user's email address.
Description	Type any optional description you want to include (for example, the user's job title). Entering a description for the user is optional. If you enter a description, enter no more than 80 characters, using the character set allowed for the full name.

## Viewing and editing user profiles

In the Edit Profile window, you can modify the user's full name, email address, or description.

To edit a user profile:

1. Log on to Navigator 2 as either system (the default administration account) or as a user who has been granted administration privileges.
2. In the Navigator 2 Explorer tree, click **Administration > Users and Permissions > Users**. The Users window appears.
3. Click a user name, then click **Edit Profile** and make the desired changes.
4. Click **OK**.

## Deleting users

If you no longer need a user, you can delete the user from Navigator 2.

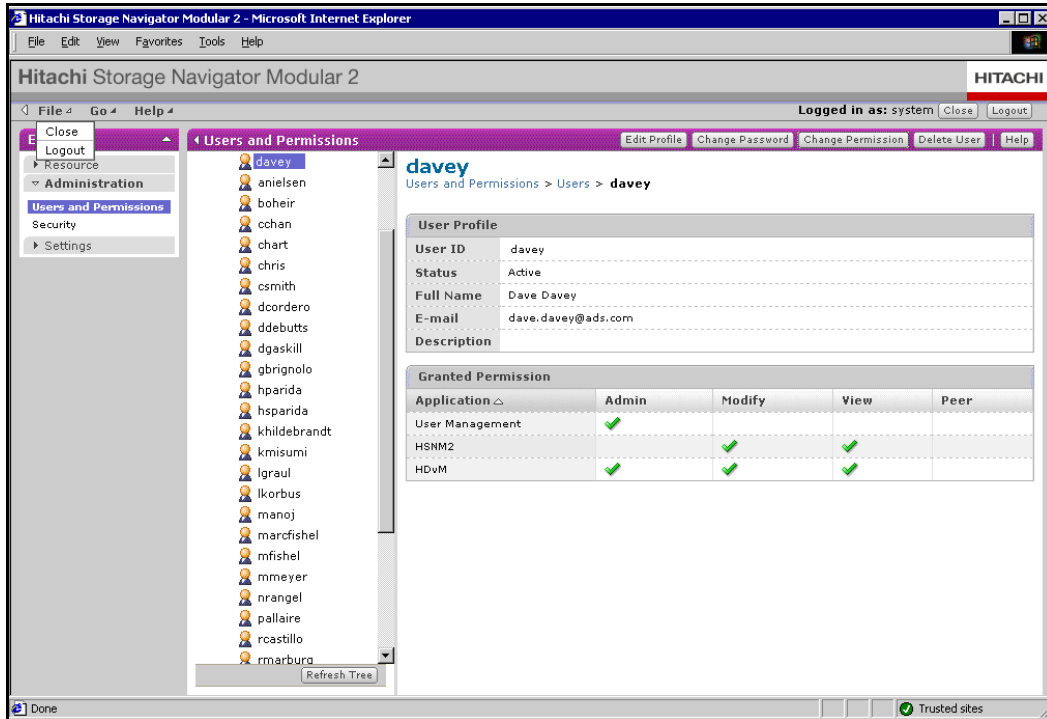
To delete a user:

1. Log on to Navigator 2 as either system (the default administration account) or as a user who has been granted administration privileges.
2. In the Navigator 2 Explorer tree, click **Administration > Users and Permissions > Users**. The Users window appears.
3. Click a user name, then click **Delete User**.
4. When a message asks whether you are sure you want to delete the selected user, click **OK** to delete the user (or click **Cancel** to retain the user).

# Understanding permissions

Permissions define the privileges Navigator 2 users have within the application. The Granted Permission table shows the permissions granted to Navigator 2 users. Check marks show permissions assigned to a user. Newly created user profiles have no check marks.

Figure 6-1 shows an example of the Granted Permission table. Table 6-2 describes the fields in the table.



**Figure 6-1: Example of Granted Permission Table**

**Table 6-2: Fields in the Granted Permission Table**

Field	Description
Application column	Shows the application to which the permission applies. Granting Admin permissions for All Applications allows the user to manage any Hitachi storage application, such as the Hitachi Storage Command Suite, that is installed on the same server. It also displays the User Management role.
User Management	Users with this permission can create or delete users and change permissions for any user on the system. This permission does not allow management of storage systems from either Navigator 2, or any other Hitachi application located in the same environment.
HSNM2	This option sets basic Storage Navigator Modular 2 administration (modify) or monitoring (view) permissions. You can select either Modify or View for this item.

**Table 6-2: Fields in the Granted Permission Table (Continued)**

Field	Description
Admin	Lets the user perform management tasks on any user account. If All Applications is also selected, this permission lets the user perform administrator functions on any other Hitachi application installed in the same environment. You can also choose another Hitachi application that the user can manage exclusively if it is installed in the same environment.
Peer	This item appears when Hitachi Device Manager is installed, with the "single sign-on" feature enabled, in the same environment as the Navigator 2 server. Peer connections are made using the HaUser account, which is a user name reserved to enable peer connections with the Hitachi Device Manager agent.

## Granting or changing permissions

To grant or change permissions for User Management:

1. Log on to Navigator 2 as either system (the default administration account) or as a user who has been granted administration privileges.
2. In the Navigator 2 Explorer tree, click **Administration > Users and Permissions > Permissions > User Management**. The User Management window appears.
3. Click a user name, then click **Change Permission** and make the desired changes. The available options are described as follows:
  - All Applications — Use this to grant permissions for any Hitachi Storage Command Suite software product that resides on the same server. For example, if Hitachi Device Manager software is installed, selecting this option will allow the user to access that application as well as Navigator 2. Changes here will also propagate to other servers using the "single sign-on" feature. Please refer to Hitachi Storage Command Suite user documentation for more information.
  - User Management — Use this option to grant administrator permissions for Navigator 2. Users with this setting can create or delete users and change permissions for any user on the system.
  - HSNM2 — Use this option to grant basic administration (modify) or monitoring (view) permissions.
4. Click **OK** to accept the changes and exit the window. Your modifications take effect immediately.

## Changing passwords

Only administrators have the permissions to set up user accounts and passwords. If you need to change your password and are not an administrator, contact your system administrator.

### Changing the default system password

For security, we recommend you change the default system password as soon as possible.

1. Log on to Navigator 2 as either system (the default administration account) or as a user who has been granted administration privileges.
2. In the Navigator 2 Explorer tree, click **Administration > Users and Permissions**.
3. In the center pane, click **System**.
4. Click **Change Password**, at top of the window in the right pane. The Change Password window appears.
5. Enter the new password in the New Password box.
6. Re-enter the new password in the Verify Password box.



**NOTE:** For security, each typed password character appears as an asterisk (\*).

---

7. Click **OK**.

### Changing a user password

To change a user password

1. Log on to Navigator 2 as either system (the default administration account) or as a user who has been granted administration privileges.
2. In the Navigator 2 Explorer tree, click **Administration > Users and Permissions**.
3. In the center pane, click the name of the user whose password you want to change.
4. Click **Change Password**, at top of the window in the right pane. The Change Password window appears.
5. Enter the new password in the New Password box.
6. Re-enter the new password in the Verify Password box.



**NOTE:** For security, each typed password character appears as an asterisk (\*).

---

7. Click **OK**.

## Password protection

Password Protection is a feature that can be used on some older Hitachi Data Systems storage systems that prevents Navigator 2 users who do not have the proper permissions to access storage systems on which password protection is set.

Password Protection can also be used to prevent simultaneous access to a storage system by more than one user. This feature is not used to control access to Navigator 2, but to the storage systems it manages.



**NOTE:** This feature is not available or used in the AMS 2000. See information on Account Authentication for information on how to secure these types of storage systems.

---

### Accessing password protection

To access the Password Protection feature for a legacy storage system:

1. In the Array List window, click the name of the storage system on which you want to set password protection. The Array Properties window for that storage system appears.
- 



**NOTE:** After you set password protection on a storage system, type a valid user ID and the password for that ID to log onto the storage system to run its properties window.

---

2. In the Explorer tree of the Array Properties window, click **Settings > Password Protection**. The Password Protection window appears, with a list of user IDs of Navigator 2 registered users. The table includes the following information for each user ID.

**Table 6-3: Password Protection User IDs**

Item	Description
User ID	Displays the ID of the Navigator 2 user.
Description	Displays the description of the user ID.

## Changing a password associated with password protection

To change the password associated with a Password Protection User ID:

1. In the Explorer tree, click **Settings > Password Protection**. The Password Protection window appears.
2. In the Password Protection window, select one or more users whose passwords you want to change and check the **Change Password** box.
3. Enter a new password for each selected user. You can use from 4 to 12 alphanumeric characters and symbols including: dashes, commas, and underbars ( "-", "\_").
4. Click **OK** to save the changes. Navigator 2 displays a message window that shows the results of the operation.
5. Click **Close** to close the window and return to the Password Protection window. The list of user IDs and new passwords appear in the window.

## Working with user IDs

User IDs are the basic building blocks that enable access into the storage system. They are useful for the purposes of security, navigation, and feature activation.

### Adding a user ID

To add one or more user IDs to a selected storage system:

1. In the Explorer tree, click **Settings > Password Protection**. The Password Protection window appears.
2. Select one or more user to add in the Password Protection window, and check the box. Click **Add User ID**.
3. Enter the information for user ID property from 4 to 12 characters (alphanumeric characters and symbols including: "-", "\_").
4. Click **OK** to save and result window displayed. Click **Close** to close the window and return to the Password Protection window. The list of user ID that you just added appears in the window.

### Changing a user ID

To change the Password Protection user ID:

1. In the Explorer tree, click **Settings > Password Protection**. The Password Protection window appears.
2. Select one or more user to add in the Password Protection window, and check the box. Click **Add User ID**.
3. Enter the information for user ID property from 4 to 12 characters (alphanumeric characters and symbols including: "-", "\_").
4. Click **OK** to save and result window displayed.
5. Click **Close** to close the window and return to the Password Protection window. The list of user ID that you just added appear in the window.

## Deleting a user ID

To delete the Password Protection user ID:

1. In the Explorer tree, click **Settings > Password Protection**. The Password Protection window appears.
2. In the Password Protection window, click the icon next to each user ID that you want to delete.
3. Click **Delete User ID**. A warning message appears.
4. In the displayed message box, read the confirmation and warnings, then click the check box to the left of the text to agree.
5. Click **Confirm** to delete the user ID (or click **Cancel** to retain it).
6. Click **Close** to close the window and return to the Password Protection window.



# Managing Storage Systems

This chapter describes how to manage Hitachi AMS 2000 Family storage systems using Navigator 2.

The topics covered in this chapter are:

- ❑ [Understanding the Arrays window](#)
- ❑ [Rebooting storage systems](#)
- ❑ [Showing and configuring storage systems](#)
- ❑ [Editing storage system settings](#)
- ❑ [Filtering storage systems](#)

## Understanding the Arrays window

Each time Navigator 2 starts after the initial startup, it searches its database for existing storage systems and displays them in the Arrays window (see [Figure 7-1 on page 7-3](#)). If another Navigator 2 window is displayed, you can redisplay the Arrays window by clicking **Resource** in the **Explorer** pane.

The Arrays window provides a central location for you to view the settings and status of the AMS 2000 Family storage systems that Navigator 2 is managing. Buttons at the top left side of the window let you run, stop, and edit error monitoring (see [Collecting Trace Information on page 11-3](#)). There is also a **Refresh Information** button you can click to update the contents in the window. Below the buttons are fields that show the storage system array status and error monitoring status.

Below the status indications are a drop-down list for viewing the number of rows and pages (25, 50, or 100), and buttons for moving to the next, previous, first, last, and a specific page in the Arrays window.

Buttons at the bottom of the Arrays window let you perform various tasks involving the storage systems shown in the window. [Table 7-1](#) describes the tasks you can perform with these buttons and the pages in this chapter where the task is described.

**Table 7-1: Arrays Window Buttons and Tasks**

Button	Task	See Page
Reboot Array	Reboot a storage system selected in the Arrays window.	<a href="#">7-3</a>
Show & Configure Array	View and configure a storage system selected in the Arrays window.	<a href="#">7-4</a>
Add Array	Add storage systems to Navigator 2 using the Add Arrays wizard.	<a href="#">4-5</a>
Edit Array	Change the name, controller IP addresses, and port settings and enable or disable error monitoring for a storage system selected in the Add Arrays window.	<a href="#">7-5</a>
Filter	Lets you set up filtering conditions to view only those storage systems that meet the filtering criteria.	<a href="#">7-7</a>
Filter Off	Turns off filtering.	<a href="#">7-7</a>
Remove Array	Removes selected storage systems from the Navigator 2 database. No precautionary message appears after you click this button, so be sure to select the appropriate storage system.	<a href="#">7-8</a>

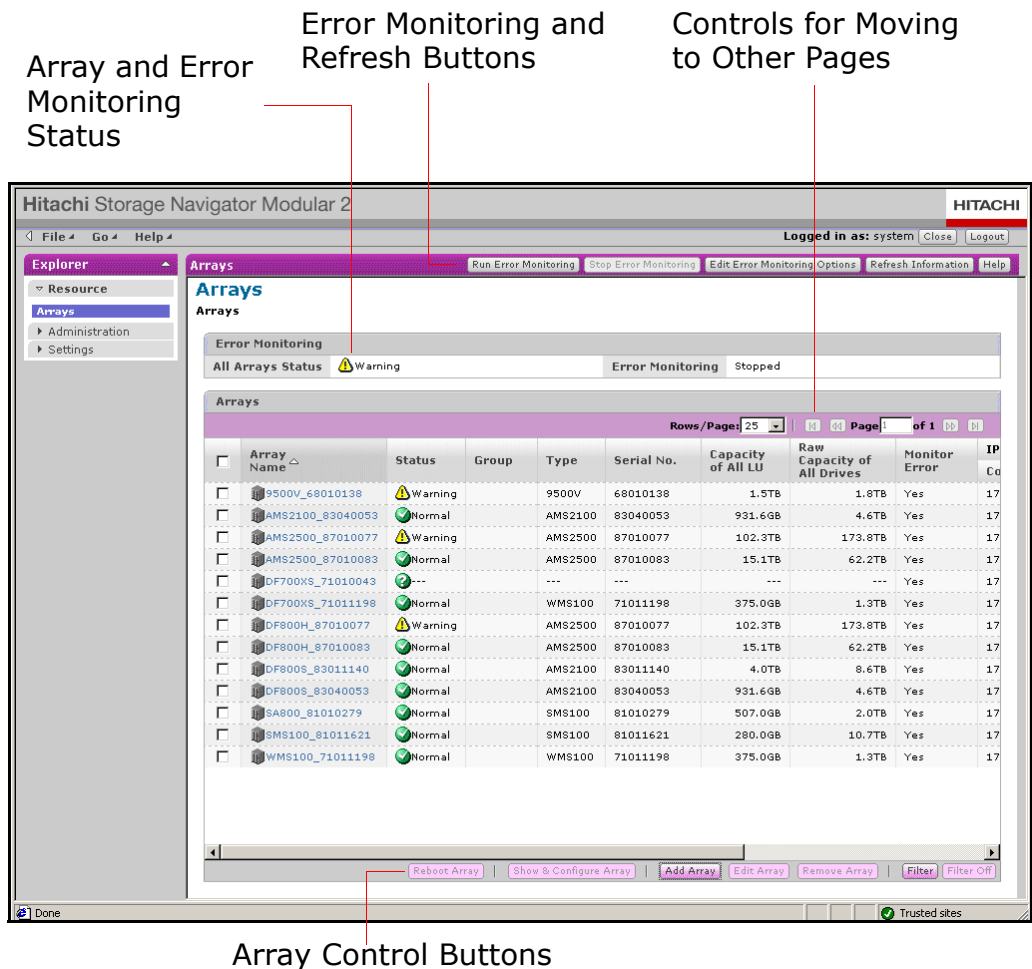


Figure 7-1: Example of the Arrays Window

## Rebooting storage systems

You can reboot a storage system from the Arrays window.

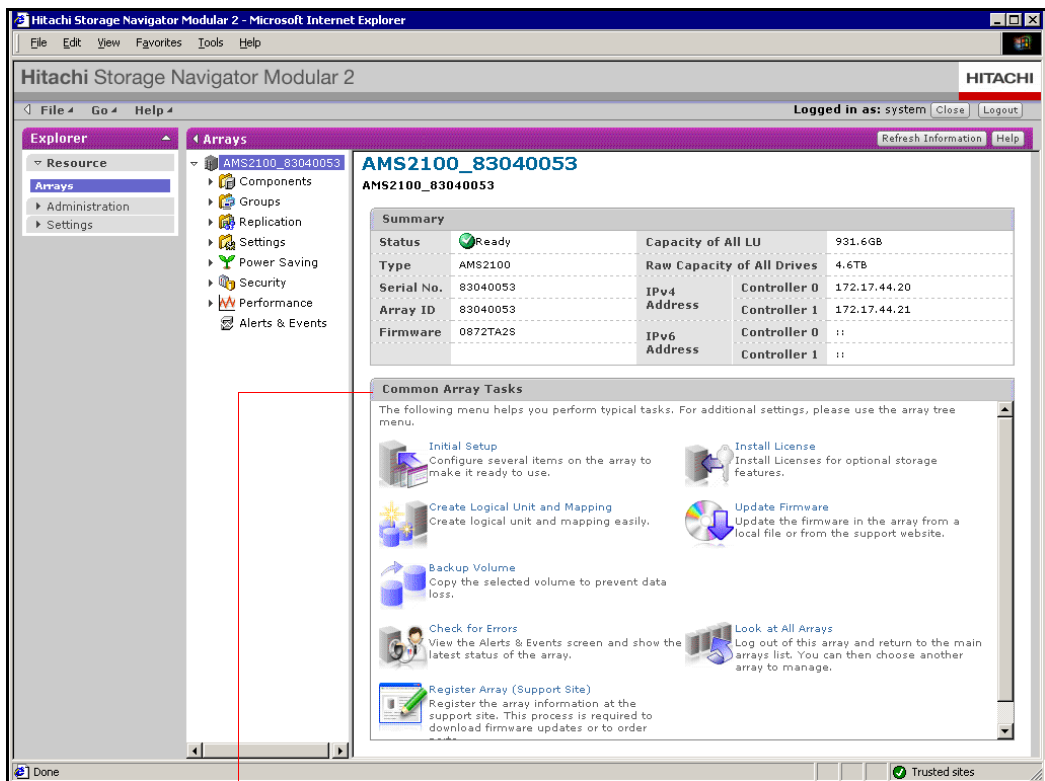
1. Stop all host I/O to the storage system you want to reboot.
2. In the left column of the Arrays window, click the check box next to the storage system you want to reboot. You can reboot only one storage system at a time.
3. Click **Reboot Array**. A precautionary messages appears.
4. In the displayed message box, read the confirmation and warnings, then click the check box to the left of the text to agree.
5. Click **Reboot Array** to reboot the storage system (or leave the check box unchecked and click **Close** to not reboot the storage system).
6. Read the message. Then click the checkbox that reads **Yes, I have read the above warning and want to reboot the array** and click **Reboot Array** to reboot the storage system (or leave the check box unchecked and click **Close** to not reboot the storage system).

## Showing and configuring storage systems

Using the **Show & Configure Array** button at the bottom of the Arrays window, you can display the Common Array Tasks menu for performing typical tasks. This button is functionally equivalent to clicking the name of a storage system under the **Array Name** column of the Arrays window.

When you select a storage system on the Arrays window and click **Show & Configure Array**, a window similar to the one in [Figure 7-2 on page 7-5](#) appears. You can then use the center pane to select commands and perform the activities described in [Description of Navigator 2 activities on page 5-5](#). You can also use the Common Array Tasks menu in the right pane to perform the following typical tasks:

- Initial setup — runs the Setup Array wizard to configure the storage system for first-time use. See [Running the Initial \(Array\) Setup wizard on page 4-7](#).
- Create Logical Unit and Mapping — lets you create logical units and mapping. See [Running the Create & Map Volume wizard on page 4-14](#).
- Backup Volume — copies selected volumes to prevent data loss.
- Check for Errors — displays the Alerts & Events window to show the latest status of the storage system. See [Managing alerts and events on page 7-13](#).
- Register Array — lets you register the storage system at the support site. We recommend that you register your storage system as soon as possible.
- Install License — lets you install licenses for optional storage features that require a license before they can be run.
- Update firmware — lets you update the storage system firmware. See the manual for your Hitachi AMS 2000 Family system.
- Look at all arrays — logs you out from the current storage system and lets you select another from the Arrays window.



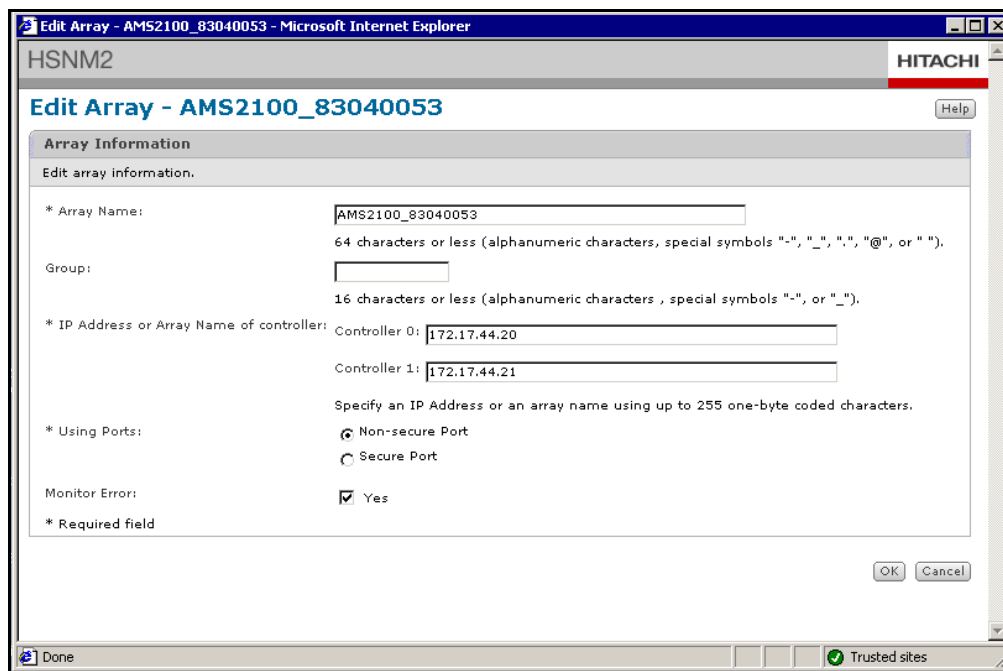
Common Array Tasks Menu

**Figure 7-2: Example of Common Array Tasks Menu**

## Editing storage system settings

You can edit the settings, such as the storage system's name, controller IP addresses, and port settings, for a storage system from the Arrays window. You can also enable or disable error monitoring for the storage system.

1. In the left column of the Arrays window, click the check box next to the storage system whose settings you want to edit.
2. Click **Edit Array**. The Edit Array window appears (see [Figure 7-3 on page 7-6](#)).



**Figure 7-3: Example of the Edit Array Window**

3. Complete the fields in the window (see [Table 7-2](#)).
4. Click **OK**.

**Table 7-2: Edit Array Settings**

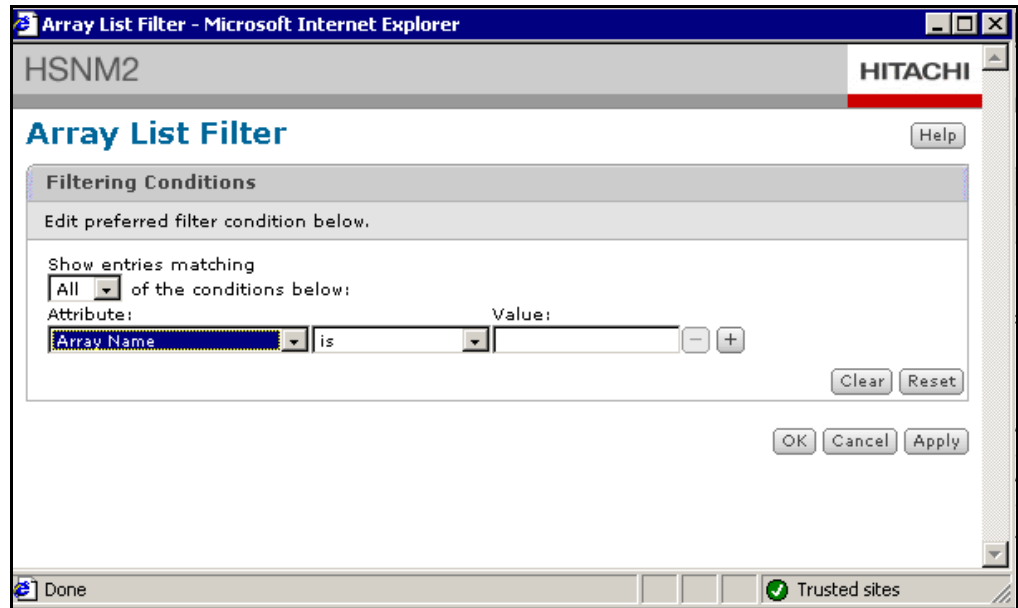
Field	Description
Array Name	Name assigned to the array that appears in the Array Name column in the Arrays window and elsewhere in Navigator 2.
Group	Name of the group to which this storage system belongs.
IP Address OR Host Name of controller	IP address or host name of this storage system.
Monitor Error	Checks for errors in the selected storage system.

## Filtering storage systems

The Arrays window provides a **Filter** button you can use to filter out storage systems that do not meet certain criteria. This feature is particularly useful if Navigator 2 is managing a large number of Hitachi storage systems and you only want to see a subset of them.

To filter storage systems:

1. In the Arrays window, click the **Filter** button. The Array List Filter window appears (see Figure 7-4).



**Figure 7-4: Example of Array List Filter**

2. In the drop-down list, select whether you want to view **All** or **Any** storage systems that meet the filtering criteria.
3. Use the **Attribute**, center, and **Value** drop-down lists to define the first criteria.
4. To define additional criteria, click the plus sign. When the next row appears, define a second set of criteria. You can also click the minus sign at the end of a row to delete that set of criteria from the filter.



**NOTE:** The more criteria you define, the narrower the filtering becomes.

5. When you finish defining criteria, click **OK**. Now only the storage systems that meet your filtering criteria appear in the Arrays window.
6. To remove all filtering criteria and redisplay all storage systems in the Arrays window, click **Filter Off**.

## Removing storage systems

If you no longer require Navigator 2 to manage a storage system, you can remove the storage system entry from the Navigator 2 database.



**CAUTION! No warning message appears before you click the Remove Array button. Therefore, be sure you no longer need a storage system to be managed by Navigator 2 before you delete the storage system from the Navigator 2 database.**

---

To remove a storage system:

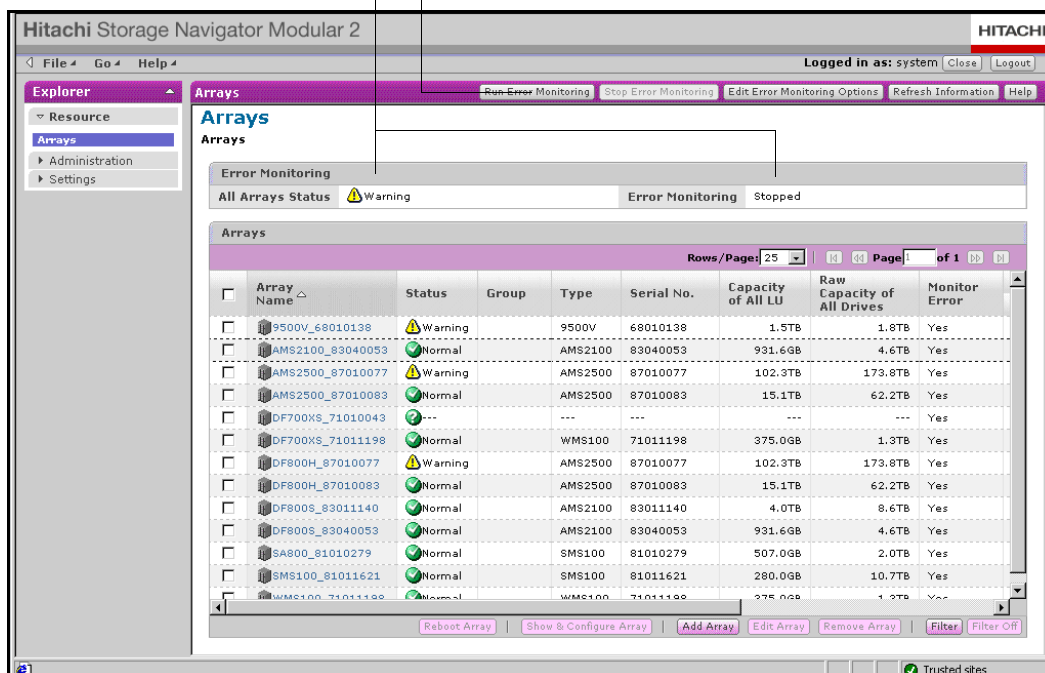
1. In the Arrays window, click the checkbox next to the storage system you want to delete.
2. Click the **Remove Array** button. The selected storage system is removed from the Arrays window and from the Navigator 2 database.

## Running error monitoring

Navigator 2 provides error-monitoring capabilities that check for errors on selected storage systems at intervals you can set. If an error is detected, Navigator 2 outputs the error to an event log (see [Managing alerts and events on page 7-13](#)) and notifies you by e-mail if configured to do so (see [Configuring email notifications on page 7-11](#)).

You configure and run error monitoring using buttons at the top of the Arrays window (see [Figure 7-5 on page 7-9](#)). Below these buttons are **All Array Status** and **Error Monitoring** fields that provide error-monitoring information about the managed storage systems (see [Table 7-3 on page 7-9](#)).

All Array Status and Error Monitoring ————— Error-Monitoring Options



**Figure 7-5: Error-Monitoring Options**

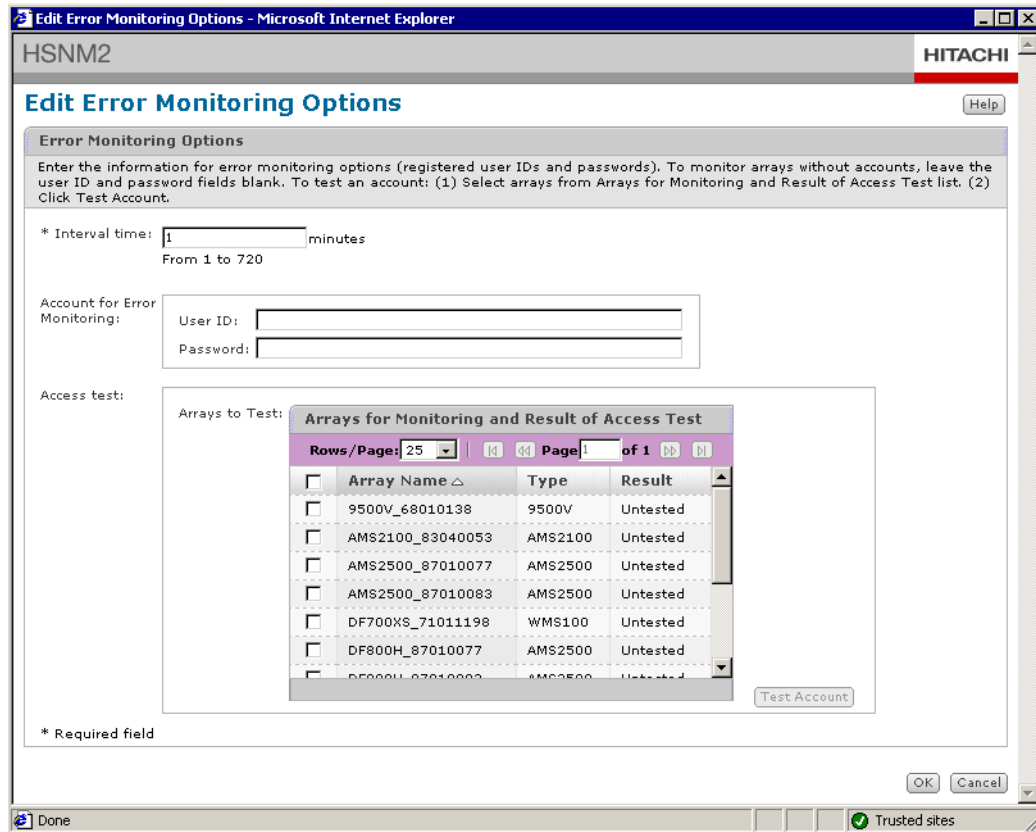
**Table 7-3: All Array Status and Error Monitoring Descriptions**

Field	Description
All Array Status	Shows the status for all storage systems that Navigator 2 is managing: <ul style="list-style-type: none"> <li><b>Normal</b> = all registered storage systems are working properly.</li> <li>The characters <b>---</b> = Navigator 2 cannot identify the storage system (for example, if the storage system power supply is off, a network communication problem occurred between Navigator 2 and the storage system, the storage system is secured by either Password Protection or Account Authentication).</li> <li><b>Warning</b> = hardware failure (controller, hard disk drive, cache memory) or communication problem between the Navigator 2 server and storage system array controller.</li> </ul>
Error Monitoring	Reports the following system status: <ul style="list-style-type: none"> <li><b>Running (Interval of N minutes)</b> = monitoring error during N minutes, where N indicates how often error checking occurs (in minutes).</li> <li><b>Stopped</b> = error monitoring is halted.</li> <li><b>Wait (Interval of N minutes)</b> = error monitoring stopped for an interval of N minutes, where N is the time before error monitoring resumes.</li> </ul>

## Configuring error monitoring options

Navigator 2 comes with preset error-monitoring options. Before you enable error monitoring, review the settings for these options and, if necessary, change them to suit your requirements.

1. In the Arrays window, click the **Edit Error Monitoring Options** button. The Edit Error Monitoring Options window appears (see [Figure 7-6](#)).



**Figure 7-6: Edit Error Monitoring Options Window**

2. Review and, if necessary, change the error-monitoring options (see [Table 7-4](#)).
3. When you finish setting the configuration options, click **OK**.

**Table 7-4: Error Monitoring Options**

Field	Description
Interval Time	Number of minutes, from 1 to 270 (12 hours), between error checks when error monitoring is turned on.
User Id	You log in to a storage system before you can monitor it in the background. Enter the user ID and corresponding password that have been defined for this storage system. To monitor storage systems without accounts, leave these fields blank.
Password	

**Table 7-4: Error Monitoring Options (Continued)**

Field	Description
Arrays to Test	Use this test to check your settings. Click to the left of a storage system name in the Arrays for Monitoring and Result of Access Test. This storage system will be used for the test. Click Test Account to start the test. When you click Test Account, the test begins immediately and runs once and a message window appears during the test. When the test ends, any errors for the selected storage system appear in the window.

## Configuring email notifications

You can configure Navigator 2 to send email notifications when errors are detected. To enable this function, complete the Set up E-mail Alert window in the Initial (Setup) Array wizard. This wizard ran automatically when you started Navigator 2 for the first time. If you did not enable this feature at that time, or if you enabled it and now want to disable it, run the Initial (Setup) Array wizard manually by clicking the name of a storage system under the **Array Name** column in the Arrays window and then clicking **Initial Setup** in the **Common Array Tasks** menu.

## Running error monitoring

After configuring the error-monitoring options, use the following procedure to run error monitoring.



**NOTE:** When error monitoring is enabled, the following functions are disabled in the Arrays window:

- Reboot Array
- Show & Configure Array
- Add Array
- Edit Array
- Remove Array
- Edit Error Monitoring Options
- Refresh Information

To use any of these functions, you must first stop error monitoring.

- 
1. In the Arrays window, click the checkbox next to the names of the storage systems you want to monitor for errors. To monitor all systems, click the topmost checkbox in the left column of the Arrays window.
  2. Click the **Run Error Monitoring** button. **Error Monitoring** in the Arrays window displays **Running** and shows the monitoring interval. The default interval can be changed in the Edit Error Monitoring Options window (see [Configuring error monitoring options on page 7-10](#)).
  3. To turn off error monitoring, click **Stop Error Monitoring**.

## Error messages

If a storage system error occurs with error monitoring running, a log file is generated that contains error information. The information is stored in a file named `errlog.txt` in the Navigator 2 installation folder. The error log text file uses the following format:

**Day, Month hh:mm:ss yyyy/<array name>/<message>**

Table 7-5 lists the log messages for Hitachi AMS 2000 storage systems.

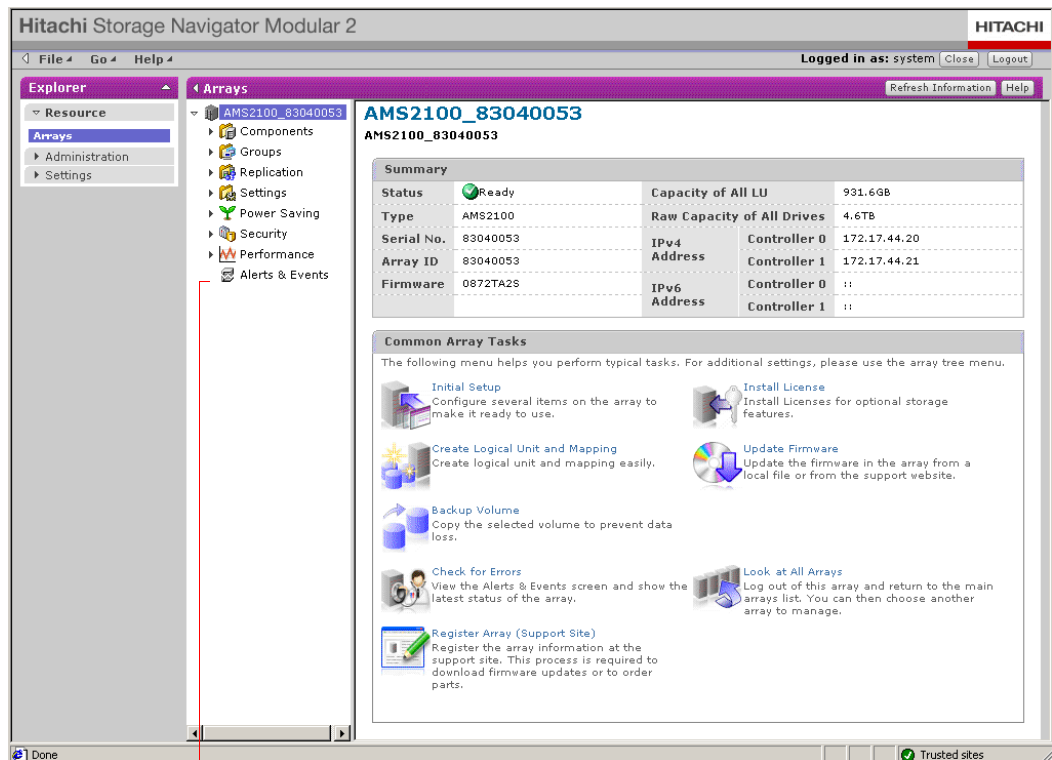
**Table 7-5: Log Messages**

Message	Description
ARRAY Hitachi Storage Navigator Modular 2 Interface error occurred.	A communication error occurred between the storage system and Navigator 2
ARRAY Warning.	General array warning
ARRAY CONTROLLER Detached. Position CONTROLLER No.xx.	Controller warning
ARRAY Cache Memory Alarm.	Cache memory warning
ARRAY Interface Board Alarm. Position CONTROLLER No.xx Interface Board No.yy.	Interface board warning
ARRAY Fan Alarm. Position CTU Fan No.yy.	Fan warning
ARRAY Fan Alarm. Position Unit No.xx Fan No.yy.	Fan warning
ARRAY Cache Backup Circuit Alarm.	Battery backup circuit warning
ARRAY AC Power Supply Failure. Position CTU AC Power No.yy.	AC power supply warning
ARRAY AC Power Supply Failure. Position Unit No.xx AC Power No.yy.	AC power supply warning
ARRAY DC Power Supply Failure. Position CTU DC Power No.yy.	DC power supply warning
ARRAY DC Power Supply Failure. Position Unit No.xx DC Power No.yy.	DC power supply warning
ARRAY Battery Alarm. Position Battery No.xx.	Battery warning
ARRAY Additional Battery Alarm. Position Additional Battery No.xx.	Additional battery warning
ARRAY ENC Alarm. Position CTU ENC No.yy.	Enclosure warning
ARRAY ENC Alarm. Position Unit No.xx ENC No.yy.	Enclosure warning
ARRAY Path Alarm.	Remote path warning
ARRAY Host Connector Alarm. Position CONTROLLER No.xx Port No.yy Host Connector No.zz.	Host connector warning
ARRAY Drive Detached.	Drive warning
ARRAY Detached Drive Position Unit No.xx HDU No.yy.	Drive warning

# Managing alerts and events

When you select an array from the Arrays window, the center pane displays the **Alerts & Events** option (see Figure 7-7). Clicking this option displays the Alerts & Events window. This window contains the following two tabs:

- Alert Parts displays alerts if there is a hardware problem (see Figure 7-8 on page 7-14).
- Event Log displays all events related to the selected storage system, such as formatting, microprogram downloads and installations, errors, and messages that the system is ready for use (see Figure 7-9 on page 7-14).



Alerts & Events

**Figure 7-7: Alerts & Events Option**

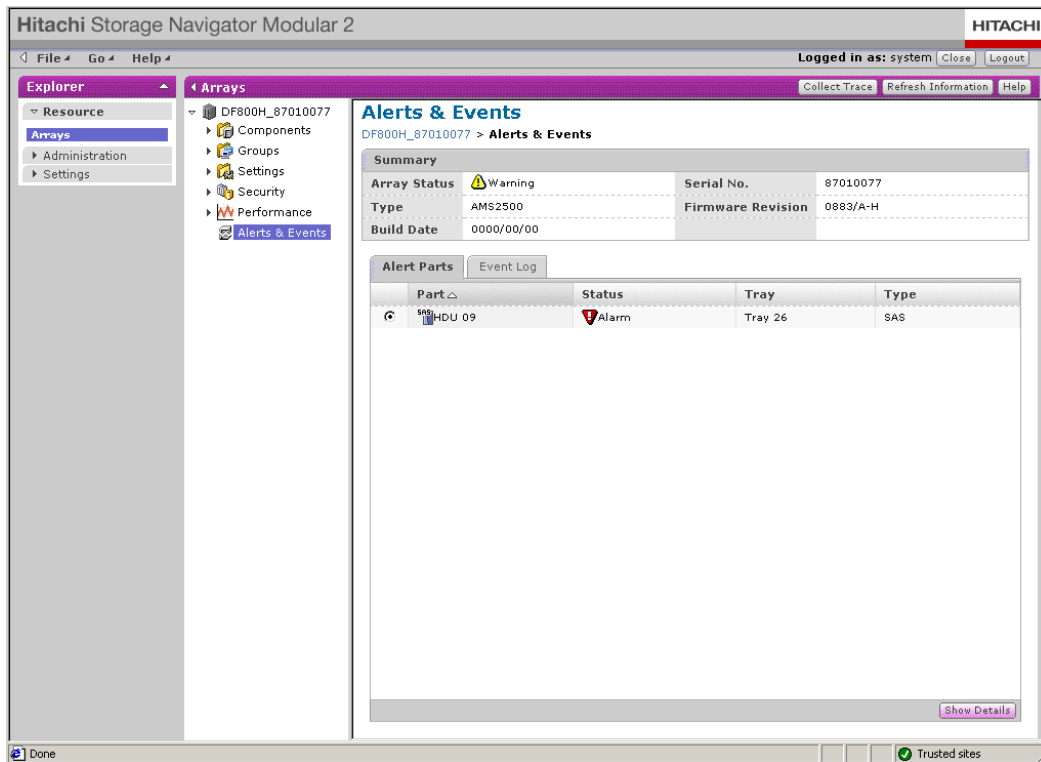


Figure 7-8: Example of the Alert Parts Tab

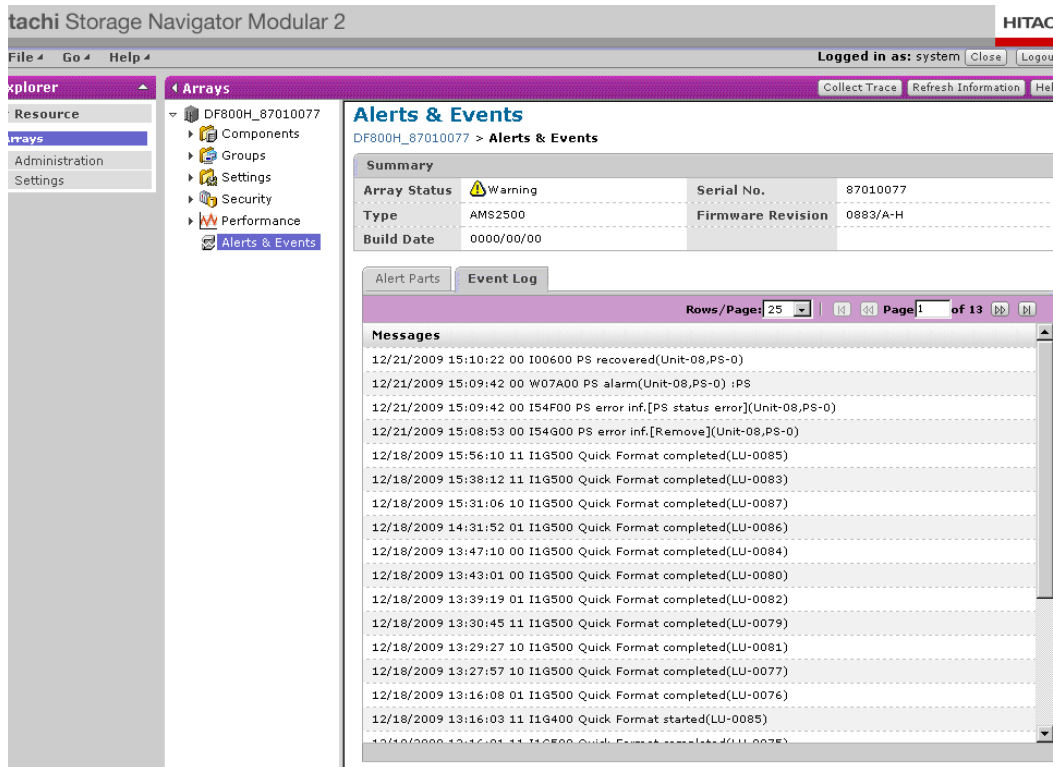


Figure 7-9: Example of the Event Log Tab

# Managing RAID Groups

This chapter describes how to manage RAID group on Hitachi AMS 2000 Family storage systems using Navigator 2.

The topics covered in this chapter are:

- ❑ [Overview](#)
- ❑ [Displaying the RAID Groups tab](#)
- ❑ [Creating a RAID group](#)
- ❑ [Expanding RAID groups](#)
- ❑ [Displaying detailed RAID group properties](#)
- ❑ [Executing a RAID group spin-up or spin-down](#)
- ❑ [Changing RAID group expansion priority](#)
- ❑ [Filtering RAID groups](#)
- ❑ [Deleting RAID groups](#)

## Overview

A RAID group can be considered as a RAID container for data protection. It can contain single or multiple parity groups. The parity groups are partitions of the RAID container. When you set up a RAID group, you can specify multiple parity groups for the RAID group that enhances performance and provides better drive access and drive rebuilding capability.

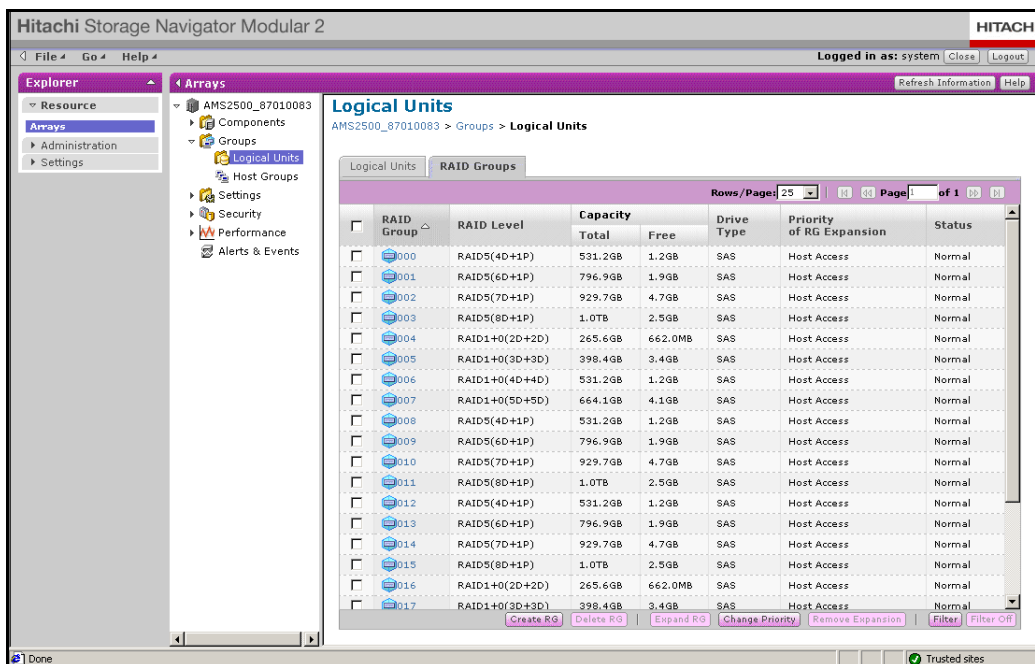
Logical units are created in a RAID group or a Dynamic Provisioning (DP) pool. Additionally, they are used in assigning a host group or iSCSI target. Multiple LUNs can be created in each RAID group, and ported to the same or different servers. This allows granularity in LUN sizes being obtained from the RAID group.

If each partition (parity group) is assigned to the same host, there should be no contention for the RAID group's disk resources. This speeds up both read and write operations to the disk, and considerably improves system performance. However, instead of creating multiple parity groups, you can use the entire RAID group as a single parity group and create one large logical unit.

## Displaying the RAID Groups tab

All RAID group activities described in this chapter, except spinning up or spinning down disks in selected RAID groups, are performed from the **RAID Groups** tab in the Logical Units window. To display this tab:

1. In the Arrays window, click a storage system whose RAID groups you want to view or configure.
2. In the center pane, click **Groups > Logical Units**. The Logical Units window appears.
3. In the Logical Units window, click the **RAID Groups** tab. [Figure 8-1 on page 8-3](#) shows an example of RAID groups in the RAID Groups tab.



**Figure 8-1: Example of RAID Groups Tab**

Table 8-1 summarizes the RAID Group activities described in this chapter.

**Table 8-1: RAID Group Tasks**

Task	See Page
Create RAID groups	<a href="#">8-3</a>
Expand RAID groups	<a href="#">8-5</a>
Remove expansion from RAID groups	<a href="#">8-8</a>
View detailed properties about the RAID groups you have defined	<a href="#">8-9</a>
Execute a RAID group spin-up or spin-down	<a href="#">8-12</a>
Change RAID group expansion priority	<a href="#">8-13</a>
Filter the RAID groups shown in the RAID Groups tab	<a href="#">8-14</a>
Delete RAID groups	<a href="#">8-15</a>

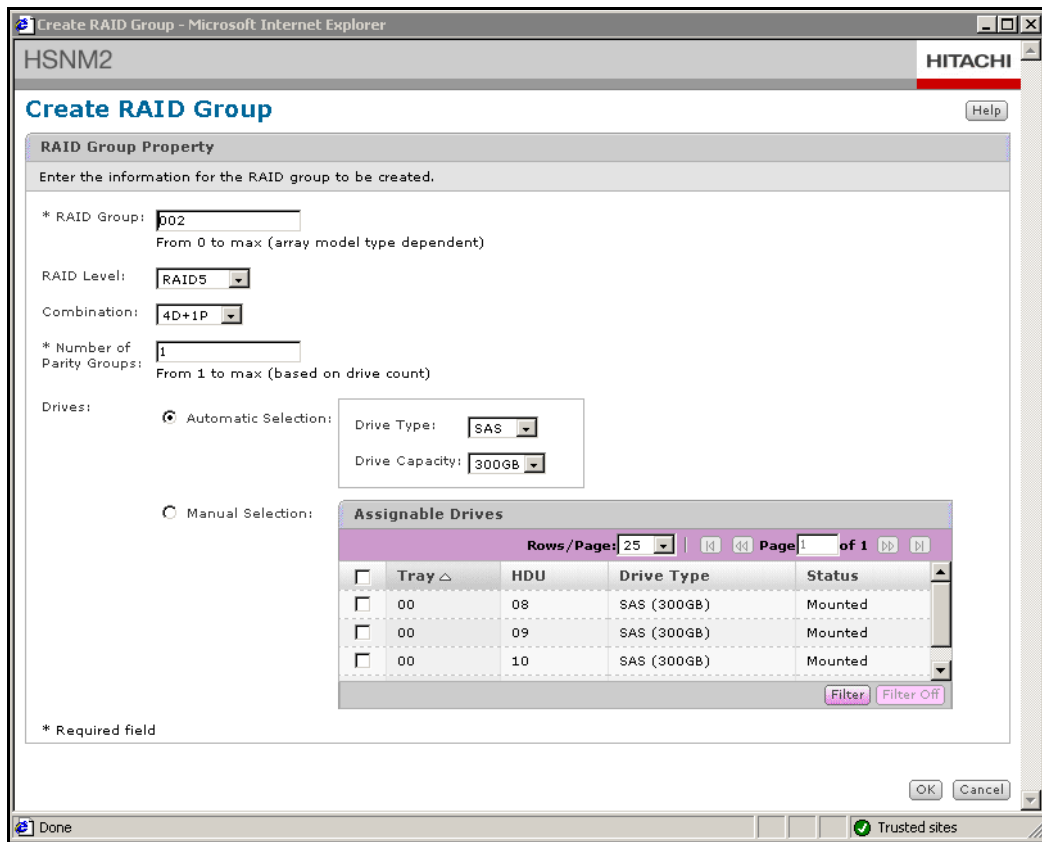
## Creating a RAID group

RAID groups can contain single or multiple parity groups. A RAID group can be considered as the actual RAID container for data protection, and the parity group as a partition of that container. This way, multiple LUNs can be created from each RAID group, and ported out to the same or different servers. This allows granularity in LUN sizes being obtained from the RAID group.

The following procedure describes how to create a RAID group. You can create a RAID group by combining only drives of the same drive type.

This procedure is intended for maintenance technicians or qualified users. Contact Hitachi Data Systems customer support if you have any questions regarding this feature.

1. In the RAID Groups tab of the Logical Units window, click **Create RG**. The Create RAID Groups window appears (see [Figure 8-2](#)).



**Figure 8-2: Example of Create RAID Groups Window**

2. Complete the fields in the window (see [Table 8-2](#)).
3. Set the drive to either **Automatic Selection** or **Manual Selection**.
4. Click **OK** to save the settings.
5. When a message states that the operation was successful, click **Close** to close the window and return to the RAID Groups window.

**Table 8-2: Fields in the Create RAID Groups Window**

Field	Description
RAID Group	Name of the displayed RAID group.
RAID Level	Number of the RAID level (1-6) that has been assigned to the RAID group.
Combination	RAID combination assigned to the RAID group.
Number of Parity Groups	Number of parity groups assigned to the RAID group.
Drives	Automatically or manually select the drives that will be a part of this RAID group.

## Expanding RAID groups

You can expand the capacity of the RAID group for AMS storage systems without interrupting host I/O by adding a drive to the specified RAID group. Data is reallocated as a background process and can require some time to complete.

RAID groups can be expanded with the following restrictions:

- Only one RAID group can be expanded per command from Navigator 2, but you can execute the command multiple times, which allows you to expand more than one RAID group per Navigator 2 session.
- The RAID group expansion process operates on a maximum of two RAID groups at a time. This means that if you issued the expansion command to additional RAID groups, those commands are queued and the expansion will be executed and other RAID groups have completed their expansion process.

The following sections describe guidelines for expanding RAID groups.

### General guidelines

You cannot expand a RAID group under the following circumstances:

- If the LU whose status of the forced parity correction is any of the following status messages observed in the RAID group of the expansion target:
  - **Correcting**
  - **Waiting**
  - **Waiting Drive Reconstruction**
  - **Unexecuted, Unexecuted 1 or Unexecuted 2**If any of the above messages are displayed, you need to execute a forced parity correction for this LU, change the LU status to **Correction Completed**, and then execute the RAID group expansion.
- If an LU is being formatted and belongs to the RAID group expansion target. Wait until the formatting has completed and then execute the expansion command from Navigator 2.
- If the following LU types are in the RAID group of the expansion target:
  - LUs set for a pair other than PSUS of ShadowImage in-system replication.
  - LUs set for a pair other than PAIR of Copy-on-write SnapShot.
  - LUs set for a pair other than PSUS of TrueCopy remote replication.
  - LUs set for a pair other than PSUS of TrueCopy Extended Distance.
  - LUs or reserve LU during Modular Volume Migration.
  - LUs in which Cache Residency Manager is set.

For any of the above conditions, change the LU status and then expand the RAID group.

- After setting or changing Cache Partition Manager configuration. The storage system must be rebooted. Expand the RAID group after rebooting the storage system.
- In which the Power Saving function is set. Change the status of the Power Saving feature to “Normal (spin-up)” and then expand the RAID group.
- When the dynamic sparing/correction copy/copy back is operating. Expand the RAID group after the drive has been restored.
- While installing the firmware. Expand the RAID group after completing the firmware installation.

## RAID group expansion best practices

Host access performance deteriorates during the RAID group expansion. Specifically, the LU in the RAID group which is expanding mostly affected. Execute the RAID group expansion at a time when host I/O is at a minimum.

For RAID group expansion, you can specify whether to give priority to the host I/O or the RAID group expansion itself.

Perform backups of all data, including data stored in cache memory, before executing the expansion. Data loss can occur due to a power or some other type of system failure, and the LU associated with the expansion can become unformatted.

The RAID group expansion expands the number of data disks of the RAID group. You cannot change the RAID level, for example from (4D+1P) to (4D+2P). You can expand the RAID group from RAID 1 to RAID 1+0. You cannot expand a RAID group that has a RAID level 0.

Only RAID groups that have one parity group can be expanded.

You can use the added capacity immediately after the expansion process has completed.

The total number of HDD that you can add is 8 per RAID group.

The drive to be added must be of the same drive type (SAS, SATA, or SSD) as the RAID group of the expansion target. Moreover, the capacity more than or equal to the minimum capacity drive in the RAID group of the expansion target is required.

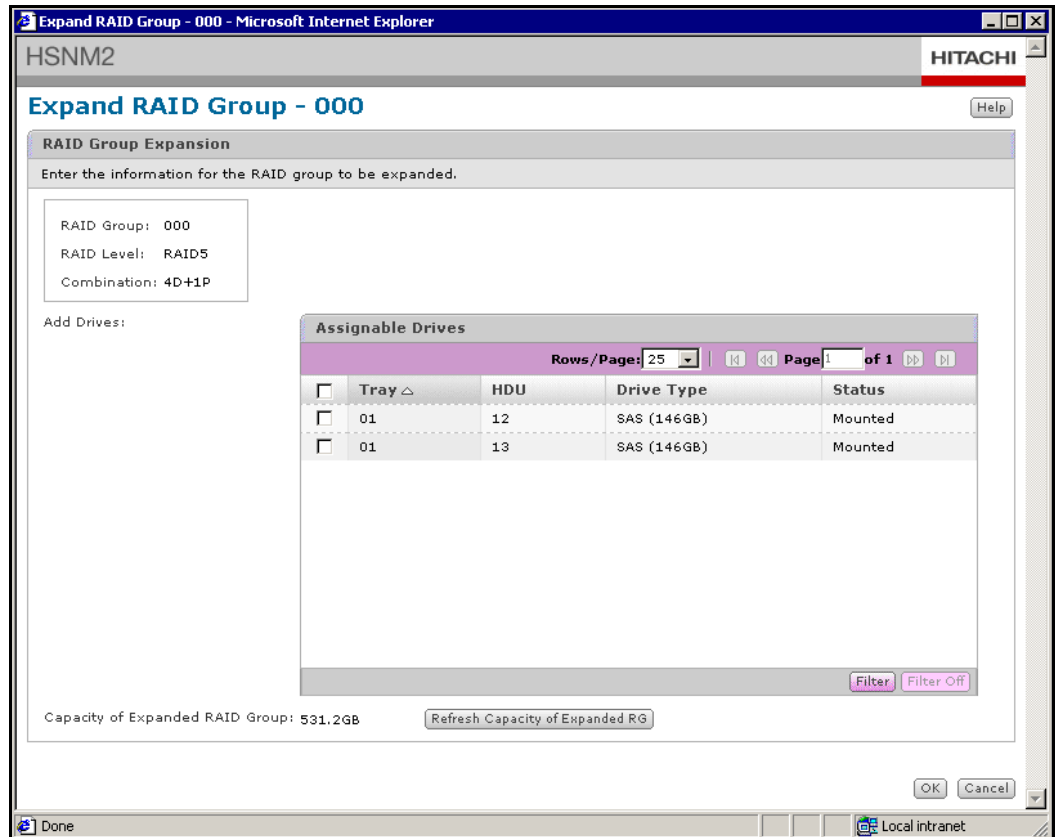
Hitachi strongly recommends that the drive added be of the same capacity and rotational speed as the RAID group of the expansion target to maximize performance.

When expanding the RAID group of RAID 1 or RAID 1+0, add drives in multiples of 2.

## Expanding RAID groups

The following procedure describes how to expand RAID group. Expanding a RAID group can affect host I/O performance during the expansion.

1. In the left column of the RAID Groups tab of the Logical Units window, click the checkbox of the RAID group you want to expand.
2. Click **Expand RG**. The Expand RAID Group window appears (see Figure 8-3).



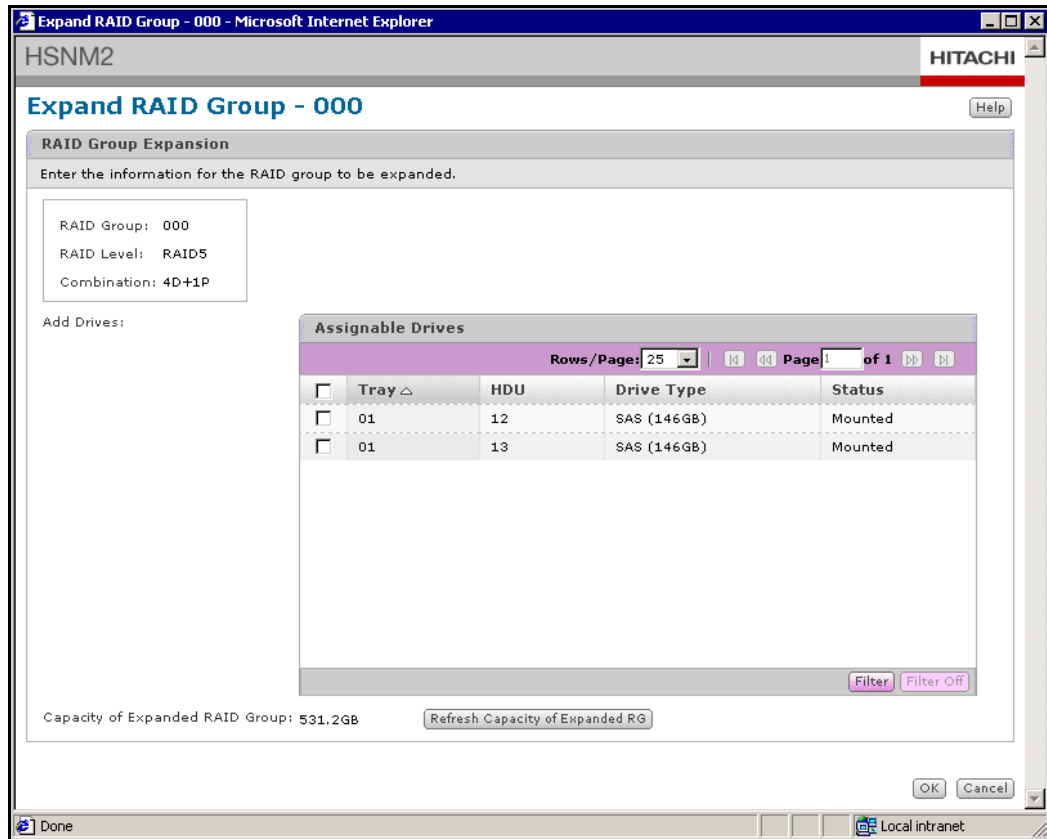
**Figure 8-3: Example of the Expand RAID Group Window**

3. Select a drive to add from the **Assignable Drives** table. If the number of drives exceeds what the table can show, use the controls at the top of the table to scroll through other drives. You can also use the **Filter** button to filter out drives that do not meet your criteria.
4. To see the resulting capacity of the expanded RAID group, click **Refresh Capacity of Expanded RG**.
5. Click **OK**. A warning message appears.
6. In the displayed message box, read the confirmation and warnings, then click the check box to the left of the text to agree.
7. Click **Confirm** to expand the RAID group (or click **Cancel** to not expand it).
8. When a message states that the operation was successful, click **Close** to close the window and return to the RAID Groups tab.

## Removing RAID group expansion

To remove RAID group expansion:

1. In the left column of the RAID Groups tab of the Logical Units window, click the checkbox of the RAID group from which you want to remove expansion.
2. Click **Remove Expansion**. The Expand RAID Group window appears (see [Figure 8-3](#)).

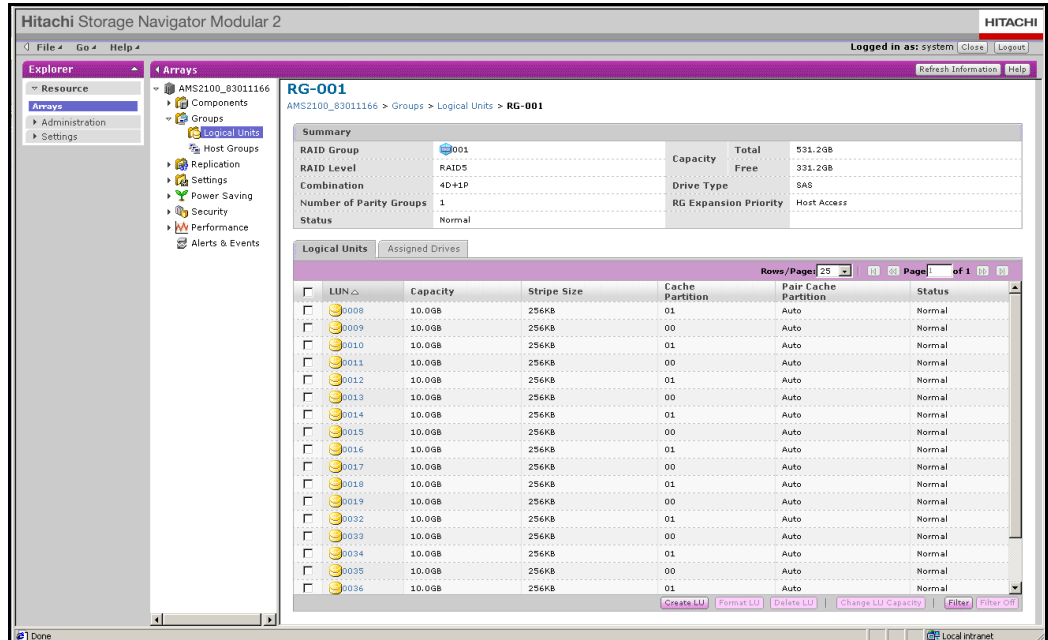


**Figure 8-4: Example of the Expand RAID Group Window**

## Displaying detailed RAID group properties

To display the detailed properties of a RAID group assigned to a storage system:

1. In the RAID Groups tab of the Logical Units window, click a RAID group under the **RAID Group** column. The Properties window for the selected RAID group appears (see [Figure 8-5](#)).



**Figure 8-5: Example of Detailed RAID Group Properties**

2. Review the fields in the **Summary** section of the window (see [Table 8-3](#)).

**Table 8-3: Fields in the RAID Group Window**

Item	Description
RAID Group	Name of the displayed RAID group. The default name for the first group is RG-000.
RAID Level	Number of the RAID level (1-6) assigned to the RAID group.
Combination	Name of the parity group that has been assigned.
Number of Parity Groups	Number of parity groups assigned to the RAID group.
Status	Status of expanded RAID group.
Capacity	Displays both the total capacity of the hard drive(s) in the RAID group and the free space left on the drive(s).
Drive Type	Displays the type of drive(s) contained in the RAID group: SAS, SATA, or SSD. You cannot mix drive types within the same RAID group.
RG Expansion Priority	The priority that displayed RG Expansion or Host Access when expand RAID group.

In addition to the **Summary** section described above, the Detailed RAID Group Properties contains two tabs:

- **Logical Units**
- **Assigned Drives**

The following sections describe each tab.

## Understanding the Logical Units tab

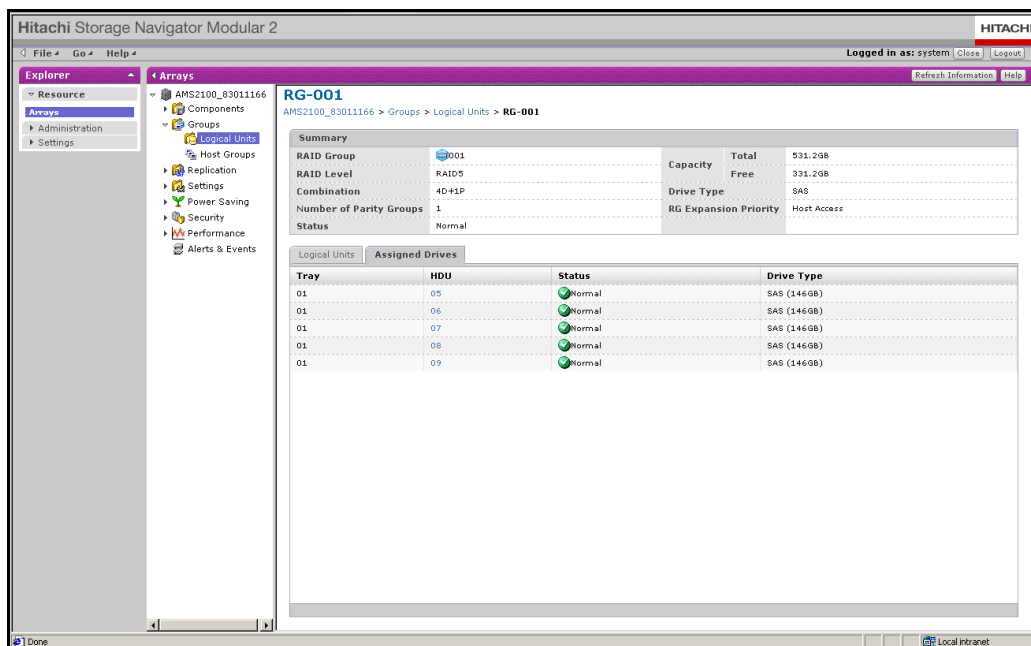
The **Logical Units** tab displays a table with a list of logical units in the selected RAID group, with statistics about each LUN. Controls at the top of the table let you display the first, next, previous, last, and specific page of the Logical Units table. [Figure 8-5 on page 8-9](#) shows an example of this tab. [Table 8-4](#) describes these statistics.

**Table 8-4: Logical Units Tab Fields**

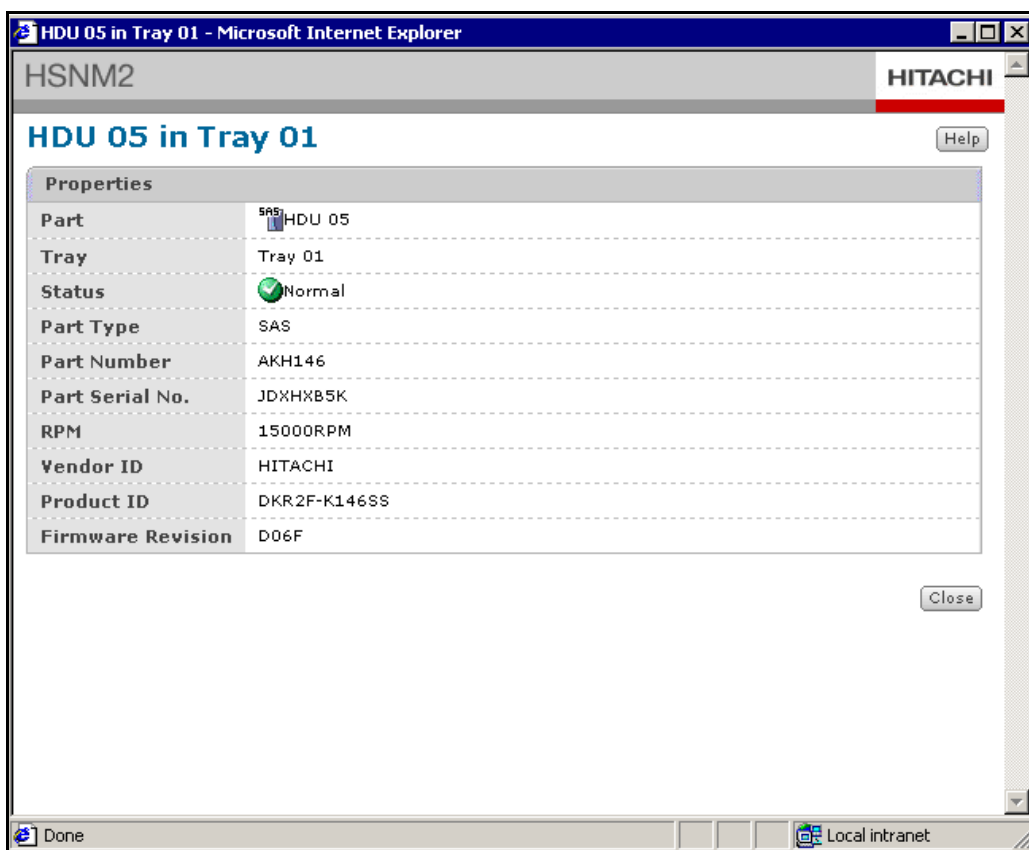
Item	Description
LUN	Displays the name of the logical unit.
Capacity	Displays the total size of the LUN in GB.
Stripe Size	Displays the size of the data stripe on the HDU (hard drive unit) that is assigned to the LUN.
Cache Partition	Displays the number of cache partitions assigned to the LUN (range is 0 to nnn).
Pair Cache Partition	Displays the number of cache partition pairs assigned to the LUN. The range is Auto, 0 - nnn).
Status	Shows the status of the LUN. Possible status can be None, Quick Formatted (and percentage completed), and Uncorrected.

## Understanding the Assigned Drives tab

The **Assigned Drives** tab displays a table with a list of the drives in the selected RAID group. [Figure 8-6 on page 8-11](#) shows an example of the Assigned Drives tab. In this tab, you can click a value in the **HDU** column to view detailed information about the HDU (see [Figure 8-7 on page 8-11](#) for example).



**Figure 8-6: Example of Assigned Drives Tab**



**Figure 8-7: Example of HDU Window**

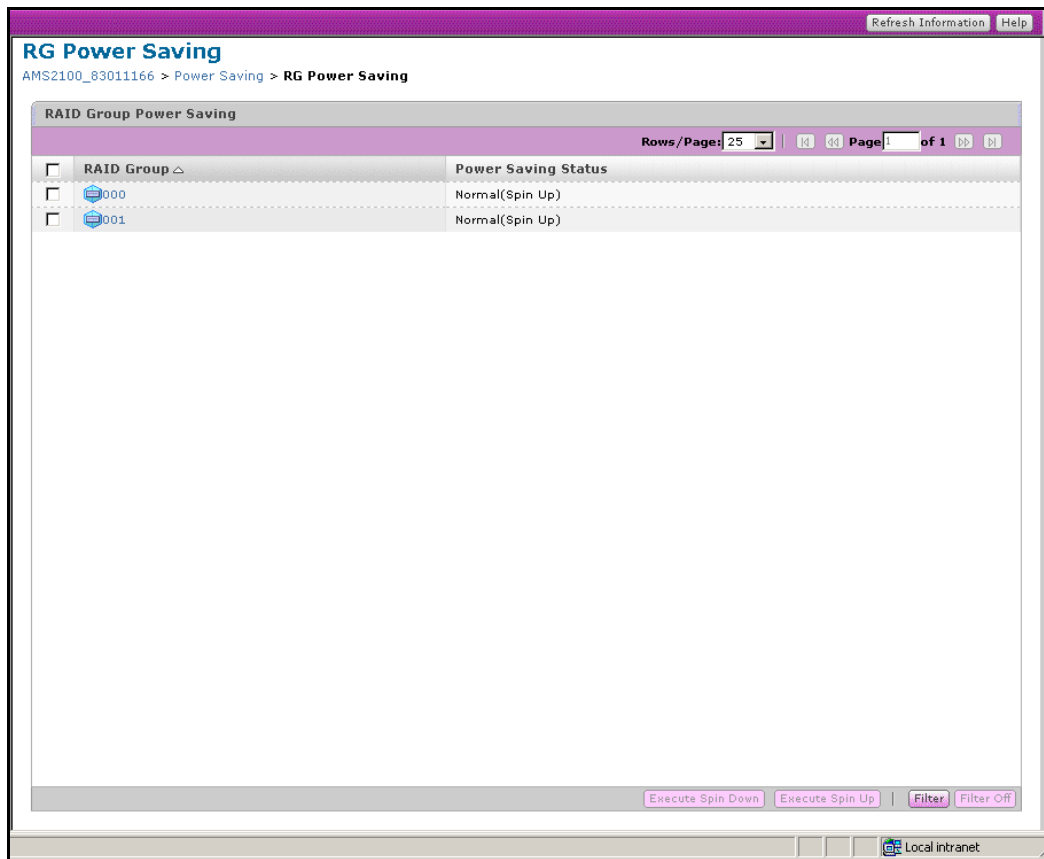
## Executing a RAID group spin-up or spin-down

Spinning down drives saves energy by spinning down the drive's motor when the drive is idle. Navigator 2 lets you configure the drives in RAID groups to spin down automatically when idle. This feature is useful for organizations having a hard time meeting the demand for power in their data centers, either because power companies cannot generate sufficient power or the required infrastructure does not exist. The amount of power that spin down saves is proportional to the amount of time a drive spends being idle. The drive's motor does not run when the drive is idle; the only power needed in idle mode is the power required by the electronics.

Alternatively, Navigator 2 lets you configure drives in RAID groups to spin-up.

To spin up or spin down the disks of a selected RAID group:

1. In the Arrays window, select the storage system whose RAID group you want to spin up.
2. In the center pane, click **Power Saving** > **RG Power Saving**. The RG Power Saving window appears (see [Figure 8-8](#)).



**Figure 8-8: RG Power Saving Window**

3. Select the RAID group that you want to spin up and click **Execute Spin Up** to spin up the disks or **Execute Spin Down** to spin down the disks in the selected RAID group. A confirmation window appears.

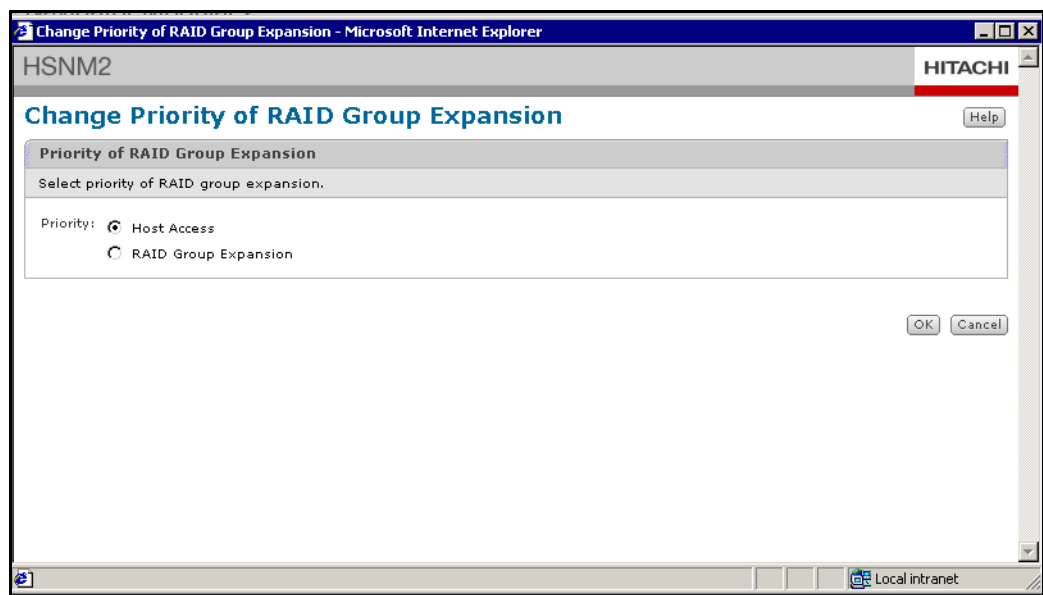
4. Review the setting in the window and click **Confirm** to perform the spin up or spin down (or click **Cancel** to cancel the operation).
5. When the next window appears, click **Close**.

## Changing RAID group expansion priority

Using the **Change Priority** button, you can change expansion priority for a selected RAID group between host access and RAID group access.

To change the RAID group expansion priority:

1. In the left column of the RAID Groups tab of the Logical Units window, click the checkbox of the RAID group whose expansion priority you want to change.
2. Click **Change Priority**. The Change Priority of RAID Group Expansion window appears (see [Figure 8-9](#)).



**Figure 8-9: Change Priority of RAID Group Expansion Window**

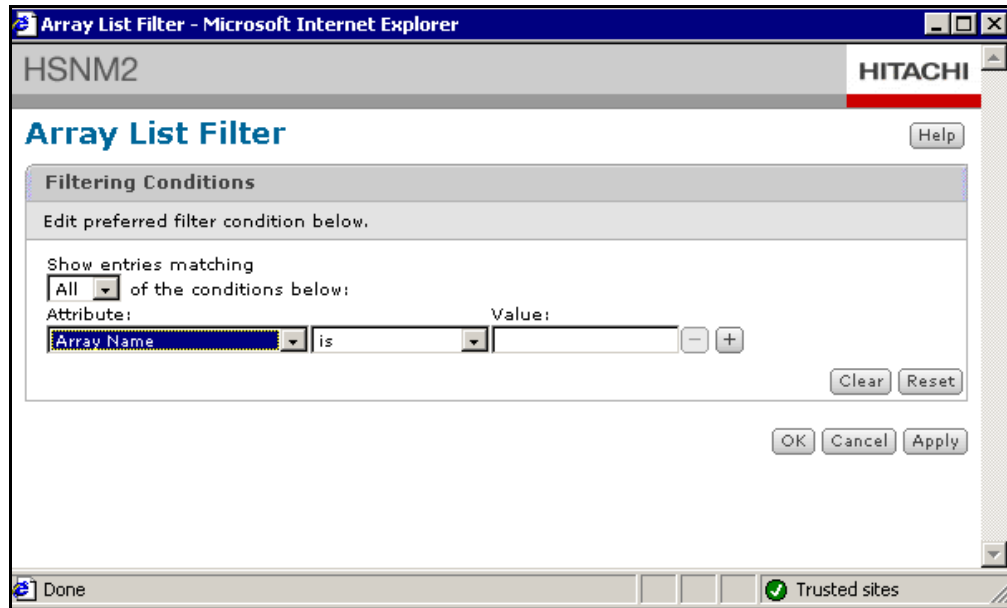
3. Click the desired priority, **Host Access** or **RAID Group Expansion**.
4. Click **OK**. A warning message appears.
5. In the displayed message box, read the confirmation and warnings, then click the check box to the left of the text to agree.
6. Click **Confirm** to change the priority (or click **Cancel** to not change the priority).
7. When a message states that the operation was successful, click **Close** to close the window and return to the RAID Groups tab.

## Filtering RAID groups

The RAID Groups tab provides a **Filter** button you can use to filter out RAID groups that do not meet certain criteria. This feature is particularly useful if you have a large number of RAID groups and only want to see a subset of them.

To filter RAID groups:

1. In the RAID Groups tab in the Logical Units window, click the **Filter** button. The Array List Filter window appears (see [Figure 8-10](#)).



**Figure 8-10: Example of Array List Filter**

2. In the drop-down list, select whether you want to view **All** or **Any** RAID groups that meet the filtering criteria.
3. Use the **Attribute**, center, and **Value** drop-down lists to define the first criteria.
4. To define additional criteria, click the plus sign. When the next row appears, define a second set of criteria. You can also click the minus sign at the end of a row to delete that set of criteria from the filter.



**NOTE:** The more criteria you define, the narrower the filtering becomes.

5. When you finish defining criteria, click **OK**. Now only the RAID groups that meet your filtering criteria appear in the RAID Groups tab.
6. To remove all filtering criteria and redisplay all RAID groups in the RAID Groups tab, click **Filter Off**.

## Deleting RAID groups

If you no longer need a RAID group, you can delete it from the RAID Groups tab. When you delete a RAID group, all logical units associated with the RAID group are also deleted.

To delete a RAID group:

1. In the left column of the RAID Groups tab of the Logical Units window, click the checkbox of the RAID group you want to delete.
2. Click **Delete RG**. A confirmation window appears.
3. In the confirmation window, click the checkbox to agree that you have read the warning message, and then click **Confirm** to delete the RAID group (or click **Cancel** to retain it).
4. Click **Close** to close the window and return to the RAID Groups tab.



# Managing Logical Units

This chapter describes how to perform logical unit tasks on Hitachi AMS 2000 Family storage systems using Navigator 2.

The topics covered in this chapter are:

- ❑ [Overview](#)
- ❑ [Displaying the Logical Units window](#)
- ❑ [Creating a logical unit](#)
- ❑ [Changing LUN capacity](#)
- ❑ [Displaying unified logical unit properties](#)
- ❑ [Formatting logical units](#)
- ❑ [Filtering logical units](#)
- ❑ [Deleting logical units](#)

## Overview

Logical units are user-designated partitions of the free storage space in a storage system and are used by a host to manage the data in the storage space they define. A logical unit can include all of the free storage space on a storage system or only part of it.

For example, you can create a logical unit for the free space on each drive, or divide the free space on a drive into parts and create a logical unit for each part. The parts can be any size you want. You could also create a logical unit that includes part of the free space on each of the drives.

The number of logical units you can create depend on your system. Refer to the user's guides for your system's specifications.

## Identifying logical units

Each logical unit is assigned a number to identify it. The numbers can be from 0 to 1023 and are called Logical Unit Numbers, or LUNs. Since the LUNs are the usual way to refer to the logical units, the acronym LUN is often used instead of logical unit.

## Types of logical units

There are several types of LUNs that can be created and used on the storage system.

- Standard logical units (LUNs) are just designated partitions of storage space. LUNs are also called volumes.
- Differential Management Logical Units (DMLUs). DMLUs are logical units that consistently maintain the differences between them.
- SnapShot Logical Units are virtual volumes and are specified as the secondary volume of a SnapShot pair when you create a pair. See Create SnapShot Logical Unit for more information.

## Understanding preconfigured logical units

AMS 2000 Family storage systems are set up at the factory with one or more logical units, depending on the model. This helps users by making the storage systems easier and faster to configure. The factory configurations are described below, by model.

AMS 2000 Family storage systems are set up at the factory with one pre-configured LUN. [Table 9-1](#) lists the parameters of that LUN. If desired, you can create additional logical units.

**Table 9-1: Preconfigured LUN on AMS 2000 Storage Systems**

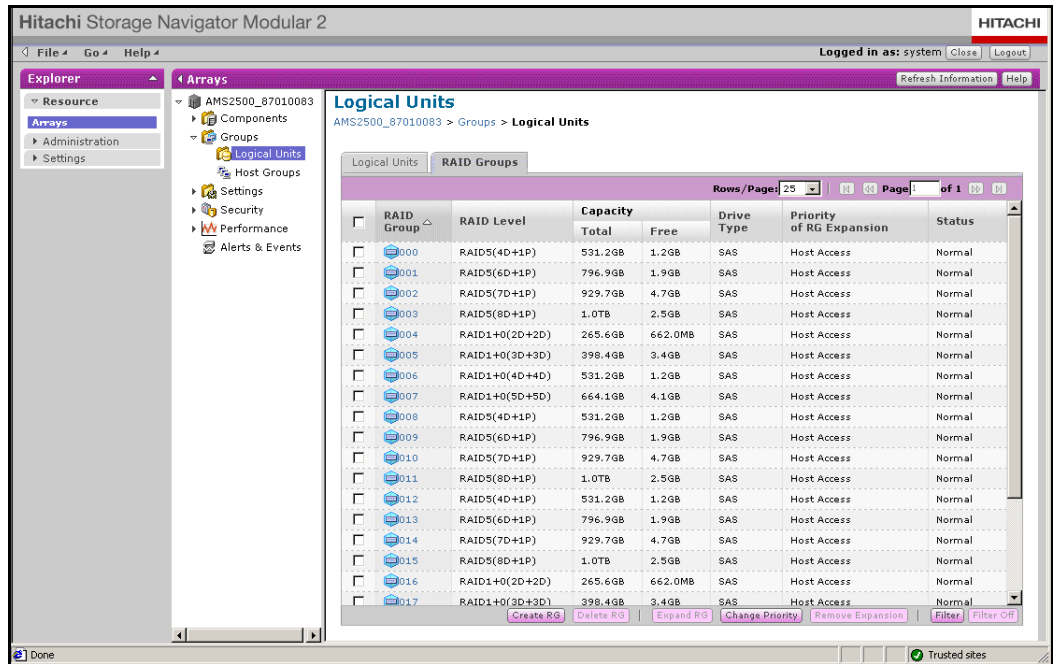
No. Ctlrs	No. LUNs	LUN Nos.	LUN Type	Size	Port	Purpose/Notes
2	1	LUN 0	LUN	50 GB	0A	<ul style="list-style-type: none"><li>• Normal use.</li><li>• Can be allocated to a host. May be spread across multiple drives.</li></ul>

## Displaying the Logical Units window

All logical unit activities described in this chapter are performed from the Logical Units window. To display this window:

1. In the Arrays window, click the name of a storage system under the **Array Name** column in the Arrays window
2. In the center pane, click **Groups > Logical Units**. The Logical Units window appears.
3. In the Logical Units window, click the RAID Groups tab. [Figure 9-1](#) shows an example of RAID groups in the RAID Groups tab.

[Table 9-2](#) summarizes the logical unit activities you can perform.



**Figure 9-1: Example of RAID Groups Tab**

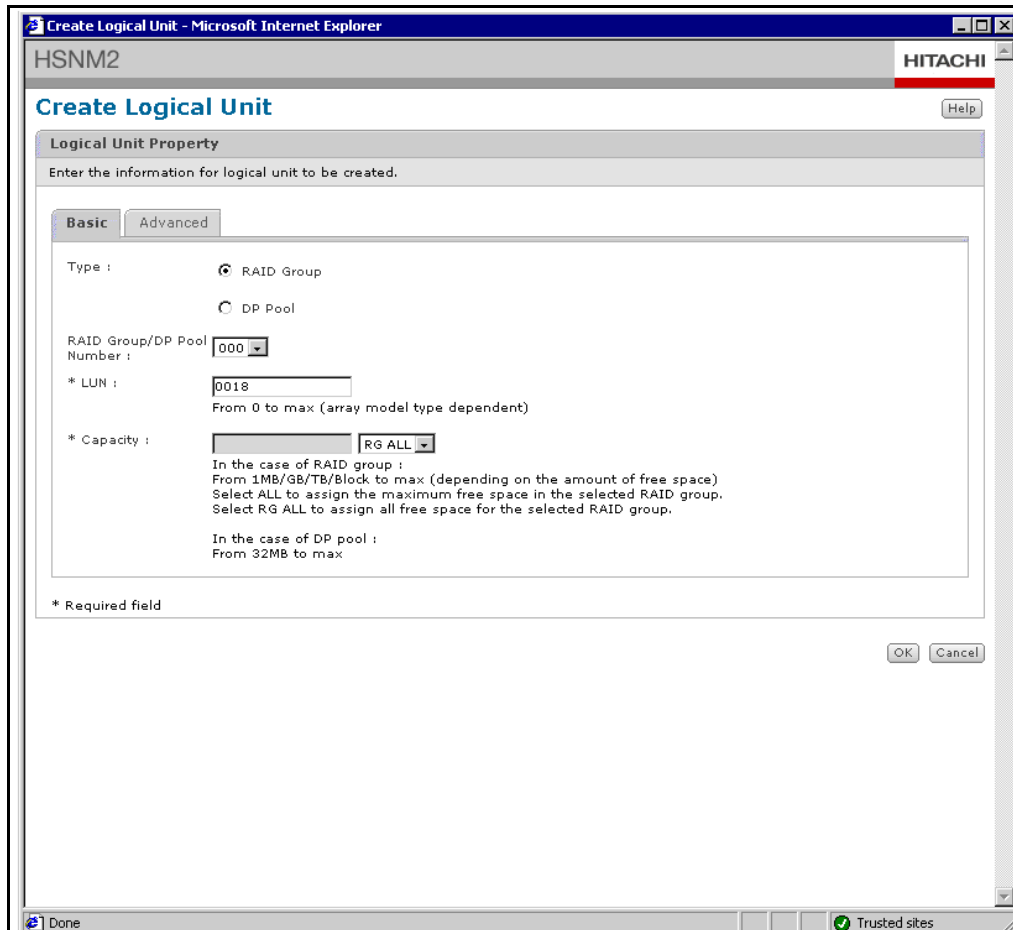
**Table 9-2: Logical Unit Tasks**

Task	See Page
Create logical units	<a href="#">9-4</a>
Change the capacity of a logical unit	<a href="#">9-6</a>
Change LUN capacity	<a href="#">9-6</a>
Display detailed properties about a logical unit	<a href="#">9-11</a>
Format logical units	<a href="#">9-11</a>
Filter logical units shown in the Logical Units tab	<a href="#">9-12</a>
Delete logical units	<a href="#">9-13</a>

## Creating a logical unit

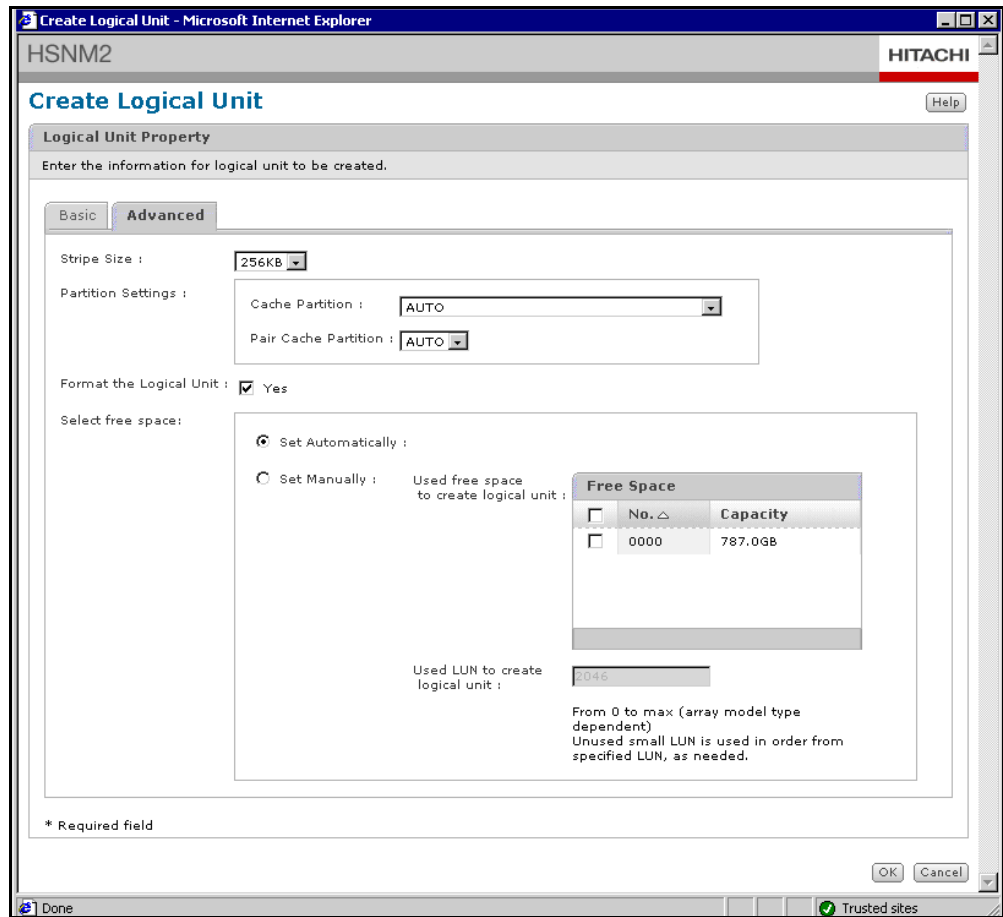
To create a logical unit:

1. In the Logical Units tab, click **Create LU**. The Create Logical Unit window appears.
2. Click the **Basic** tab as shown [Figure 9-2](#).



**Figure 9-2: Create Logical Unit Window (Basic Tab)**

3. Complete the settings in the tab (see [Table 9-3 on page 9-5](#)).
4. To set advanced options, click the **Advanced** tab as shown in [Figure 9-3](#) and complete the settings (see [Figure 9-3 on page 9-5](#)). If you do not need advanced settings, or if you created a logical unit in the DP pool, skip to the next step.



**Figure 9-3: Create Logical Unit Window (Advanced Tab)**

5. Click **OK**.
6. When the results window appears, click **Close**.

**Table 9-3: Create Logical Unit Window (Basic Tab)**

Field	Description
RAID Group	Select a RAID group from the drop-down list.
LUN	From 0 to the maximum supported by the storage system.
Capacity	<ul style="list-style-type: none"> <li>• For RAID groups: from 1MB/GB/TB/Block to max (depending on the amount of free space) Select ALL to assign the maximum free space in the selected RAID group. Select RG ALL to assign all free space for the selected RAID group.</li> <li>• For a DP pool: from 32MB to the maximum supported by the storage system.</li> </ul>

**Table 9-4: Create Logical Unit Window (Advanced Tab)**

Field	Description
Stripe Size	Size to write separated data to drive.
Partition Settings	Specify the cache partition and pair cache partition settings.
Format the Logical Unit	Check to format the created logical unit. For a logical unit in the RAID group, the format is performed on the six logical units per controller at the same time. If you specify more logical units than the controller allows, the units enter a queue and wait until the system is available to process them. They are released from the queue for processing when the logical units that entered the optimization cycle before the maximum amount reached has completed processing. The waiting logical units execute automatically when they can be accepted.
Select free space	Amount of free space you want to create for the logical unit and set manually or set automatically. To set manually, check a selection in the Free Space table. In the Used LUN to create Logical Unit field, specify the first LUN to be used to create the LU. Note that in some storage systems, you cannot set automatically or manually, and can only select free space.

## Changing LUN capacity

After you create a logical unit, you can expand (grow) or reduce (shrink) its size. You can also unify (concatenate) or separate logical units to increase capacity. You perform these tasks from the Change Logical Unit Capacity window.

## Guidelines when expanding logical units

Observe the following guidelines when expanding or reducing logical units.

### Expanding logical units

You cannot expand a logical unit under the following circumstances:

- When the logical unit you want to expand is being formatted.
- For a unified logical unit configured using logical units of two or more RAID groups.
- During a drive restoration is in progress on the affected logical unit. Execute after completing the drive restoration.
- On the following types of logical unit:
  - Logical units set as a pair of ShadowImage in-system replication
  - Logical units set as a pair of Copy-on-write SnapShot
  - Logical units set as a pair of TrueCopy remote replication
  - Logical units set as a pair of TrueCopy Extended Distance
  - Logical units or reserve logical units for Modular Volume Migration
  - Logical units in which Cache Residency Manager is set
  - Logical units being formatted

- Logical units set for a command device
- Differential Management Logical Units (DMLUs)
- Logical units registered in the data pool
- Logical units in the RAID group during a RAID group expansion
- Logical units of a RAID group in which spin-down is enabled.  
Change the status of the Power Saving feature to **Normal (spin-up)** and then expand the logical units (see [Executing a RAID group spin-up or spin-down on page 8-12](#)).

## Reducing logical units

You cannot reduce a logical unit under the following circumstances:

- When the logical unit's properties are set to **Read Only, Protect** or **Can't Guard**.
- When the logical unit's S-VOL setting is Setting Impossible (disabled) and the mode is either Read Capacity 0 (Zero) or Inquiry Command Shielding (Zer/Inv).
- If the Data Retention Utility is enabled and its properties are set to **Read/Write**, or if the S-VOL is set to **Setting Possible (Enabled)**, and mode to **Unset**, and then reduce logical units.

In addition, wait until a drive is restored before reducing the logical units if the dynamic sparing/correction copy/copy back operation is in progress.

## Changing the capacity of a logical unit

The following procedure describes how to change the capacity of a logical unit. Do not skip any steps and be sure to follow the instructions carefully. If you do not perform a step correctly, data in the storage system can be lost and the unified logical unit will not be created.

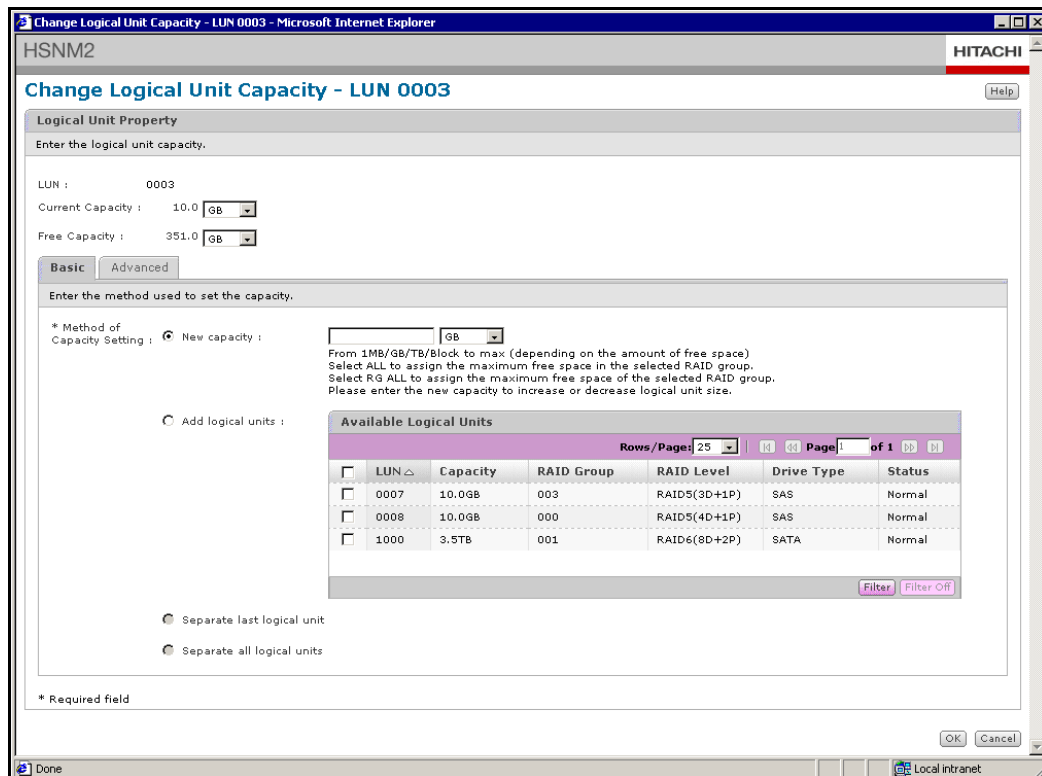
Before beginning any LUN expansion procedure, note the following.

- Back up the unified logical units before modifying them.
- Format the unified logical units to delete the volume label which the operating system adds to logical units.
- Create unified logical units only from logical units within the same storage system.
- You must format a logical unit that is undefined before you can use it.
- You can increase the size of a logical unit using the available free space within the RAID group to which it belongs.
- You can change the capacity of a logical unit adding existing logical units to a selected logical unit.

After observing the guidelines above, use the following procedure to change the capacity of a logical unit.

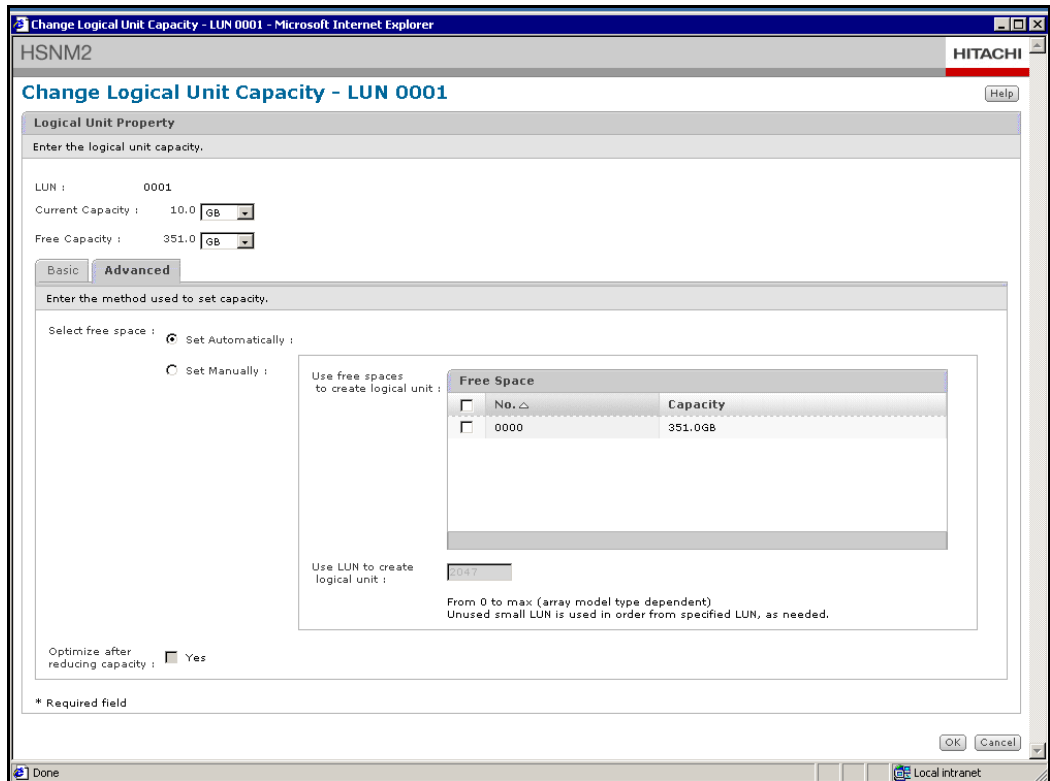
1. In the Logical Units window, check the LUN whose capacity you want to change.

2. Click **Change LU Capacity**. The Change Logical Unit Capacity window appears, showing the current properties of the selected LUN (see [Figure 9-4](#)). The free capacity (space) does not display for logical units that are members of a DP pool.
3. Review and complete the following settings at the top of the window:
  - LUN — read-only field that shows the number of the selected LUN.
  - Current Capacity — enter the size of the unified logical unit. The drop-down list lets you select the desired increment (for example, GB, TB, Block).
  - Free Capacity — logical unit's free capacity. The drop-down list lets you select the desired increment (for example, MB, GB, TB, Block).
4. Complete the settings in the **Basic** tab (see [Table 9-3 on page 9-5](#)).



**Figure 9-4: Example of Change Logical Unit Capacity Window (Basic Tab)**

5. To set advanced settings, click the **Advanced** tab as shown in [Figure 9-4](#) and complete the settings (see [Table 9-5 on page 9-10](#)).



**Figure 9-5: Example of Change Logical Unit Capacity Window (Advanced Tab)**

6. Click **OK**. A confirmation window appears.
7. In the confirmation window, click the checkbox to agree that you have read the warning message, and then click **Confirm** to change the capacity of the logical unit (or click **Cancel** to retain the current capacity).
8. Click **Close** to exit the message box and return to the Logical Units window.

**Table 9-5: Change Logical Unit Capacity Window — Basic Tab**

Field	Description
Method of Capacity Setting	Select one of the following options: <ul style="list-style-type: none"> <li>• New capacity — enter a new capacity value and use the drop-down list to select one of the following options: <ul style="list-style-type: none"> <li>• An increment (MB, GB, etc.).</li> <li>• ALL = assigns the maximum free space in the selected RAID group.</li> <li>• RG ALL = assigns the maximum free space of the selected RAID group.</li> </ul> </li> <li>• Add logical units — check the checkbox that corresponds to a LUN from the Available Logical Units table.</li> </ul>
Separate last logical unit	Removes the last logical unit that was added to a unified logical unit.
Separate all logical units	Separates a unified logical unit into the original logical units that were used to create it.

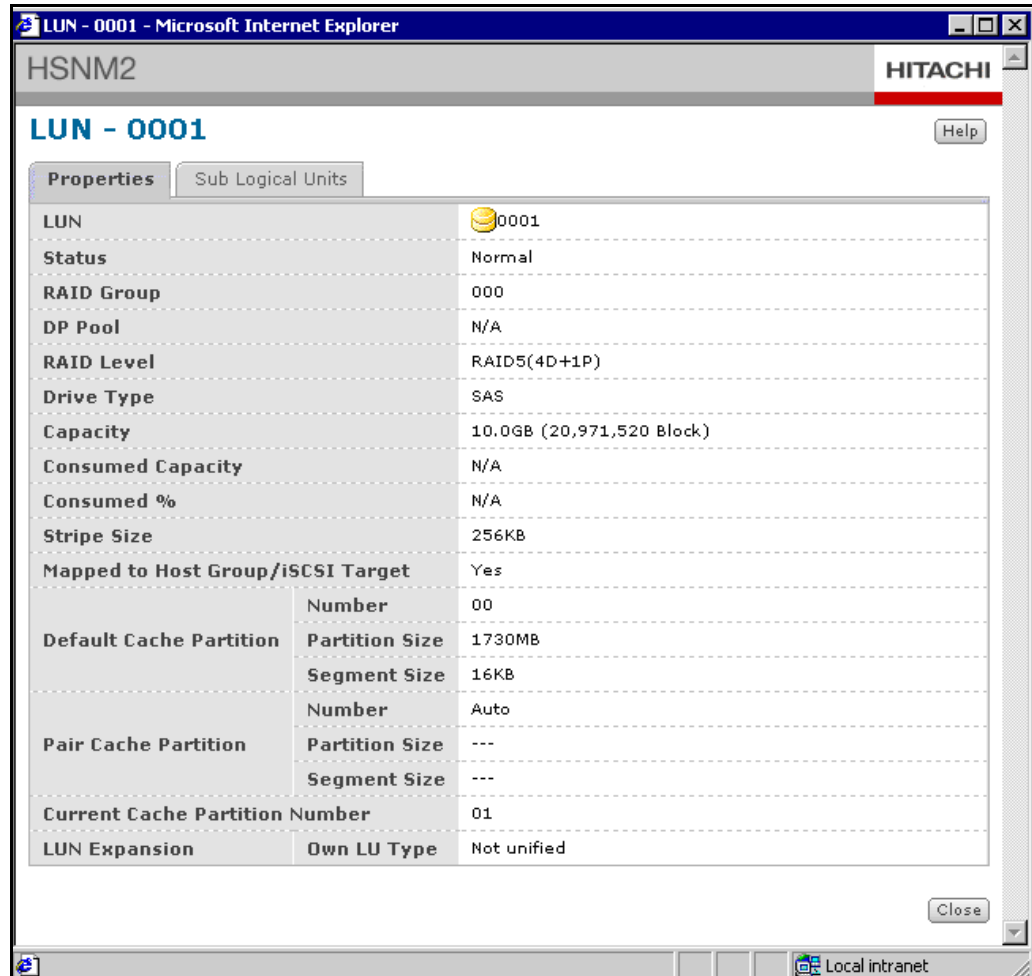
**Table 9-6: Change Logical Unit Capacity Window — Advanced Tab**

Field	Description
Select free space	Select one of the following options: <ul style="list-style-type: none"> <li>• Set Automatically — allocates free space automatically to the logical unit, without requiring your intervention</li> <li>• Set Manually — lets you allocate free space to the logical unit by selecting an option from the Free Space table</li> </ul>
Use LUN to create logical unit	Enter the LUN to be used to create the logical unit.
Optimize after reducing capacity	Check this checkbox to optimize the logical unit.

## Displaying unified logical unit properties

To display the list of unified logical units:

1. In the Logical Units window, click a LUN under the **LUN** column. The LUN screen appears, with detailed information about the selected LUN shown in the **Properties** tab (see [Figure 9-6 on page 9-11](#)).



The screenshot shows a web browser window titled "LUN - 0001 - Microsoft Internet Explorer". The page displays the "Properties" tab for LUN - 0001. The interface includes a "Help" button and a "Close" button. The main content is a table of properties for the selected LUN.

LUN		0001
Status		Normal
RAID Group		000
DP Pool		N/A
RAID Level		RAID5(4D+1P)
Drive Type		SAS
Capacity		10.0GB (20,971,520 Block)
Consumed Capacity		N/A
Consumed %		N/A
Stripe Size		256KB
Mapped to Host Group/iSCSI Target		Yes
Default Cache Partition	Number	00
	Partition Size	1730MB
	Segment Size	16KB
Pair Cache Partition	Number	Auto
	Partition Size	---
	Segment Size	---
Current Cache Partition Number		01
LUN Expansion	Own LU Type	Not unified

**Figure 9-6: Example of LUN Screen — Properties Tab**

2. To view information about the sub-logical unit information about the selected logical unit, click the Sub Logical Units tab.
3. When you finish viewing the logical unit information, click **Close**.

## Formatting logical units

If you no longer need a logical unit, you can delete it from the Logical Units window. When you delete a logical unit:

- The data becomes unusable. Systems or applications that use this storage system may end unexpectedly. Please make sure to stop the host access to the storage system before performing this operation.
- You will not be able to recover your data. Please make sure to perform backup of all important data before this operation.



**CAUTION! You cannot undo this operation.**

To format a logical unit:

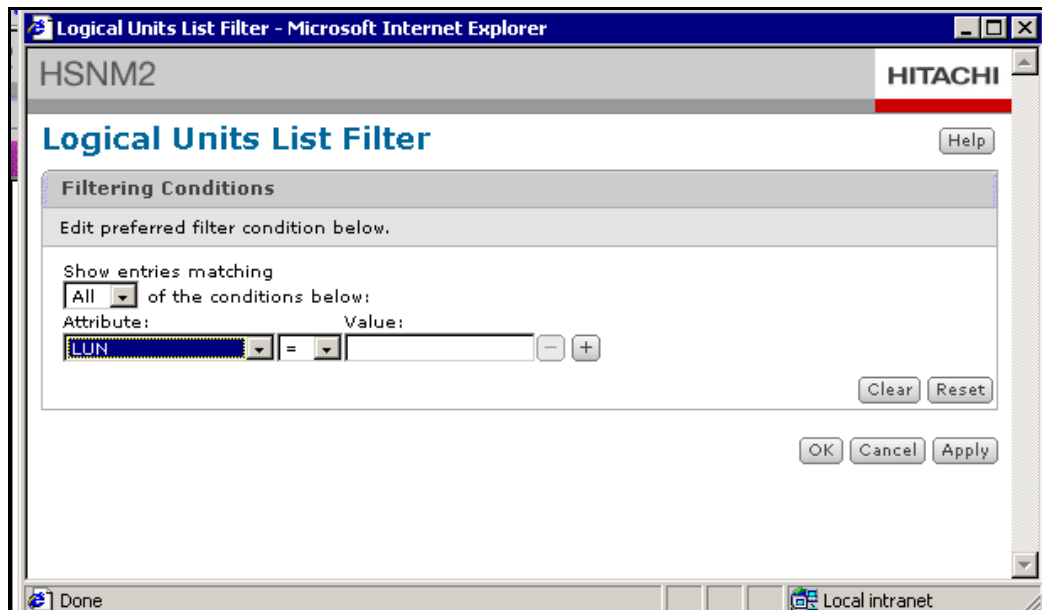
1. In the left column of the Logical Units window, click the checkbox of the logical unit you want to format.
2. Click **Format LU**. A confirmation window appears.
3. In the confirmation window, click the checkbox to agree that you have read the warning message, and then click **Confirm** to format the logical unit (or click **Cancel** to not format it).
4. Click **Close** to close the window and return to the Logical Units window.

## Filtering logical units

The Logical Units tab provides a **Filter** button you can use to filter out logical units that do not meet certain criteria. This feature is particularly useful if you have a large number of logical units and only want to see a subset of them.

To filter logical units:

1. In the Logical Units window, click the **Filter** button. The Logical Units Filter List Filter window appears (see [Figure 9-7](#)).



**Figure 9-7: Example of Logical Units Filter List**

2. In the drop-down list, select whether you want to view **All** or **Any** logical units that meet the filtering criteria.
3. Use the **Attribute**, center, and **Value** drop-down lists to define the first criteria.

4. To define additional criteria, click the plus sign. When the next row appears, define a second set of criteria. You can also click the minus sign at the end of a row to delete that set of criteria from the filter.



**NOTE:** The more criteria you define, the narrower the filtering becomes.

---

5. When you finish defining criteria, click **OK**. Now only the logical units that meet your filtering criteria appear in the Logical Units window.
6. To remove all filtering criteria and redisplay all logical units in the Logical Units window, click **Filter Off**.

## Deleting logical units

If you no longer need a logical unit, you can delete it from the Logical Units window. When you delete a logical unit:

- The data becomes unusable. Systems or applications that use this storage system may end unexpectedly. Please make sure to stop all host access to the storage system before performing this operation.
- You will not be able to recover your data. Please make sure to perform backup of all important data before this operation.

You cannot delete a logical unit whose status following a forced parity correction has any of the following status messages:

- **Correcting**
- **Waiting**
- **Waiting Drive Reconstruction**
- **Unexecuted, Unexecuted 1 or Unexecuted 2**

If any of the above messages appear, execute a forced parity correction for the logical unit, change the logical unit status to **Correction Completed** or **skip**, and then delete this logical unit.

To delete a logical unit:

1. In the left column of the Logical Units window, click the checkbox of the logical unit you want to delete.
2. Click **Delete LU**. A confirmation window appears.
3. In the confirmation window, click the checkbox to agree that you have read the warning message, and then click **Confirm** to delete the logical unit (or click **Cancel** to retain it).
4. Click **Close** to close the window and return to the Logical Units window.



## Advanced Functions

This chapter describes how to perform advanced Navigator 2 functions.

The topics covered in this chapter are:

- ❑ [Using Internet Protocol Version 6](#)
- ❑ [Using secure sockets layer](#)
- ❑ [Changing the IP Address for connecting to Navigator 2](#)
- ❑ [Changing the Default Port Number for Navigator 2](#)
- ❑ [Starting or stopping the Navigator 2 service or daemon process](#)
- ❑ [Starting the Hitachi Storage Command Suite common components](#)
- ❑ [Starting the Navigator 2 server service or daemon process](#)
- ❑ [Using the SATA Write and Compare feature](#)
- ❑ [User Account settings for HiCommand Device Manager and Navigator 2](#)

# Using Internet Protocol Version 6

Most of today's Internet uses Internet Protocol version 4 (IPv4). However, with the popularity of IP-enabled devices that access Internet and packet-switched internetworks, there is an increasing shortage of IPv4 addresses. As the next-generation Internet protocol, IPv6 fixes the problem of dealing with a limited number of available IPv4 addresses.

## IPv6 guidelines

Some Navigator 2 windows allow you to enter IPv6 addresses, as well as IPv4 addresses. This section provides guidelines when using IPv6 addresses with Navigator 2.

## Navigator 2 supported operating systems for IPv6

Table 10-1 lists the IPv6-supported operating systems.

**Table 10-1: IPv6-Supported Operating Systems**

Operating System	Notes
Solaris 8 (SPARC)	
Solaris 9 (SPARC)	
Solaris 10 (SPARC)	
Solaris 10 (x86)	Supported only on the client
Solaris 10 (x64)	
Windows Server 2003 (x86), SP 1	
Windows Server 2003 (x86), SP2	
Windows Server 2003 R2 (x86), SP1	
Windows Server 2003 R2 (x64), SP1	
Windows Vista (x86), SP1	
Windows Server 2008 (x86), SP1, SP2	
Windows Server 2008 (x64), SP1, SP2	
Windows 7 (x86), no SP	
Windows 7 (x64), no SP	
Windows Server 2008 R2 (x64), no SP	
Red Hat Enterprise Linux AS 4.0 update 1	Address searching function is not supported on the server
Red Hat Enterprise Linux AS 4.0 update 5	Address searching function is not supported on the server

## IPv6 link-local addresses

Based on RFC 2462, all IPv6 nodes automatically configure a link-local address for each interface. By default, the IPv6 protocol for the supported Microsoft Windows operating systems in Table 10-1 on page 10-2 configure link-local addresses for each interface that corresponds to an installed Ethernet network interface card (NIC). Link-local addresses have the prefix

FE80::/64. The last 64 bits of the IPv6 address is referred to as the interface identifier. It is derived from the 48-bit Media Access Channel (MAC) address of the NIC.

To create the IPv6 interface identifier from the 48-bit (6-byte) Ethernet MAC address:

- The hexadecimal digits 0xFF-FE are inserted between the third and fourth bytes of the MAC address.
- The Universal/Local bit (the second low-order bit of the first byte of the MAC address) is complemented. If it is a 1, it is set to 0; if it is a 0, it is set to 1.

For example, for the MAC address of 00-60-08-52-F9-D8:

- The hexadecimal digits 0xFF-FE are inserted between 0x08 (the third byte) and 0x52 (the fourth byte) of the MAC address, forming the 64-bit address of 00-60-08-FF-FE-52-F9-D8.
- The Universal/Local bit, the second low-order bit of 0x00 (the first byte) of the MAC address, is complemented. The second low-order bit of 0x00 is 0 which, when complemented, becomes 1. The result is that for the first byte, 0x00 becomes 0x02.

As a result, the IPv6 interface identifier that corresponds to the Ethernet MAC address of 00-60-08-52-F9-D8 is 02-60-08-FF-FE-52-F9-D8.



**NOTE:** If you use IPv6 addresses with your storage system, we recommend you set IP addresses manually on the Navigator 2 Set up Management Ports window. If you select **Use DHCP** in the Navigator 2 Set up Management Port window, the IPv6 address changes if you replace storage systems, since the IPv6 address is created based on the storage system's MAC address. This will require you to perform the Navigator 2 search array and registration.

---



**TIP:** For the range of the IPv6 address set manually, use the global unicast address 2001::/16.

---

The link-local address of a node is the combination of the prefix FE80::/64 and the 64-bit interface identifier expressed in colon-hexadecimal notation. As a result, the link-local address of this example node, with the prefix FE80::/64 and the interface identifier 02-60-08-FF-FE-52-F9-D8, is FE80::260:8FF:FE52:F9D8.

You can view your link local address using the **netsh interface ipv6 show interface** command. When you run this command without any additional parameters, a list similar to the following appears:

Idx	Met	MTU	State	Name
5	0	1500	Connected	Local Area Connection
4	0	1500	Connected	Local Area Connection 2
3	1	1280	Connected	6to4 Tunneling Pseudo-Interface
2	0	1280	Connected	Automatic Tunneling Pseudo-Interface
1	0	1500	Connected	Loopback Pseudo-Interface

For more detailed output, you can designate a connection name as a command parameter (for example, **netsh interface ipv6 show interface "Local Area Connection 2"**). Using the interface parameter (with either an interface name or an interface index number) results in the following output, which includes the link local address for the connection:

```
Interface 4: Local Area Connection 2

Addr Type   DAD State   Valid Life   Pref. Life   Address
-----
Temporary Preferred 6d4h41m33s  4h38m46s  3ffe:2900:d005:f282:4063:32a8:5c81:62f2
Temporary Deprecated 5d4h44m24s  0s 3ffe:2900:d005:f282:cd74:3dd7:857b:b57
Temporary Deprecated 4d4h47m16s  0s 3ffe:2900:d005:f282:d880:d193:f2dd:d929
Temporary Deprecated 3d4h50m7s  0s 3ffe:2900:d005:f282:7482:2f05:8129:54ba
Temporary Deprecated 2d4h52m59s  0s 3ffe:2900:d005:f282:d530:25de:57b:7ee0
Temporary Deprecated 1d4h55m50s  0s 3ffe:2900:d005:f282:c58c:4290:22c6:7b3b
Temporary Deprecated 4h58m42s  0s 3ffe:2900:d005:f282:8464:acf0:8393:cf6
Public Preferred 29d23h57m19s 6d23h57m19s fec0::f282:2c0:4fff:fe19:bad3
Public Preferred 29d23h57m19s 6d23h57m19s 3ffe:2900:d005:f282:2c0:4fff:fe19:bad3
Link Preferred infinite infinite fe80::2c0:4fff:fe19:bad3

Connection Name      : Local Area Connection 2
GUID                 : {433F15CA-E3FD-4DE4-B3FF-7EF4B30CA4E7}
State                : Connected
Metric               : 0
Link MTU              : 1500 bytes
True Link MTU        : 1500 bytes
Current Hop Limit    : 64
Reachable Time       : 4h43m20s
Base Reachable Time  : 8h20m
Retransmission Interval : 16m40s
DAD Transmits        : 1
DNS Suffix            : example.microsoft.com
Zone ID for Link     : 4
Zone ID for Site     : 1
Uses Neighbor Discovery : Yes
Sends RA's           : No
Forwards Packets     : No
Link-Layer Address   : 00-c0-4f-19-ba-d3
```

In this example, Interface 4 is an interface that corresponds to an installed Ethernet adapter with a link-local address of FE80::2C0:4FFF:FE19:BAD3.

## Router discovery

IPv6 solves many problems related to the interaction between nodes that are attached to the same link. To accomplish this, an IPv6 host “advertises” its presence, various link parameters, and various Internet parameters using router discovery — an exchange of Router Solicitation and Router Advertisement messages — to ascertain additional addresses and configuration settings.

To accomplish this, routers “advertise” their presence, various link parameters, and various Internet parameters. Routers advertise either periodically, or in response to a router solicitation message. Router advertisements contain prefixes that are used for on-link determination or address configuration, a suggested hop limit value, and other purposes.

If you need to change the contents of a router advertisement for a host attached to the storage system, use the command **set Router Lifetime** and specify an expiration date of 0 to disable the previous router advertisement. Otherwise, you will have to perform the Navigator 2 search array and registration.

## Temporary addresses

Computers running Microsoft Windows Vista or Windows Server 2008 by default generate random interface IDs for non-temporary auto-configured IPv6 addresses, including public and link-local addresses, instead of EUI-64-based interface IDs. As a public IPv6 address is a global address that is registered in DNS and is typically used by server applications for incoming connections, such as a Web server.

This default setting can cause many temporary addresses to be registered in the hot, increasing processing times. Therefore, we recommend you check the temporary addresses and, if there are many, disable them.

To check whether a temporary addresses is enabled or disabled, type the following command from the command prompt.

```
C:\> netsh interface ipv6 show privacy
```

To disable temporary addresses, type the following command:

```
C:\> netsh interface ipv6 set privacy disable
```

Type the following command to return them to Enabled.

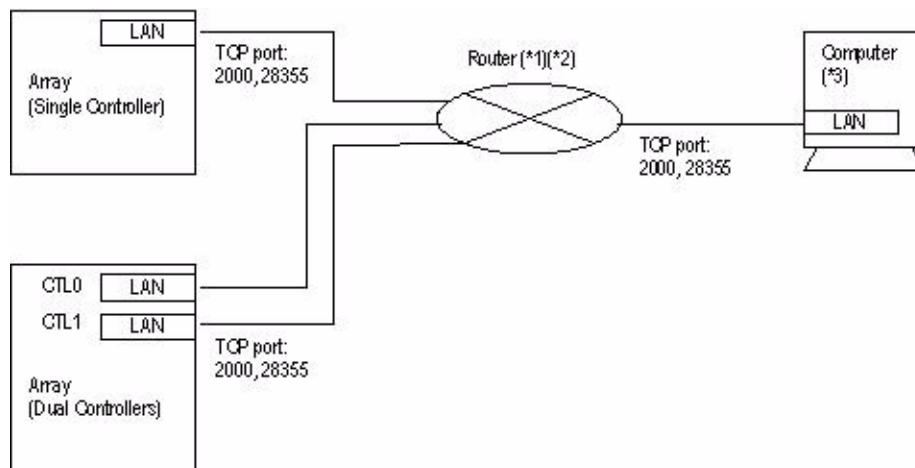
```
C:\> netsh interface ipv6 set privacy enable
```

## Connection methods

The following examples show connections between the storage system and the computer in which Navigator 2 has been installed.

### Example 1

[Figure 10-1 on page 10-6](#) shows a configuration where a computer with Navigator 2 and the computer have the same IPv6 addresses.



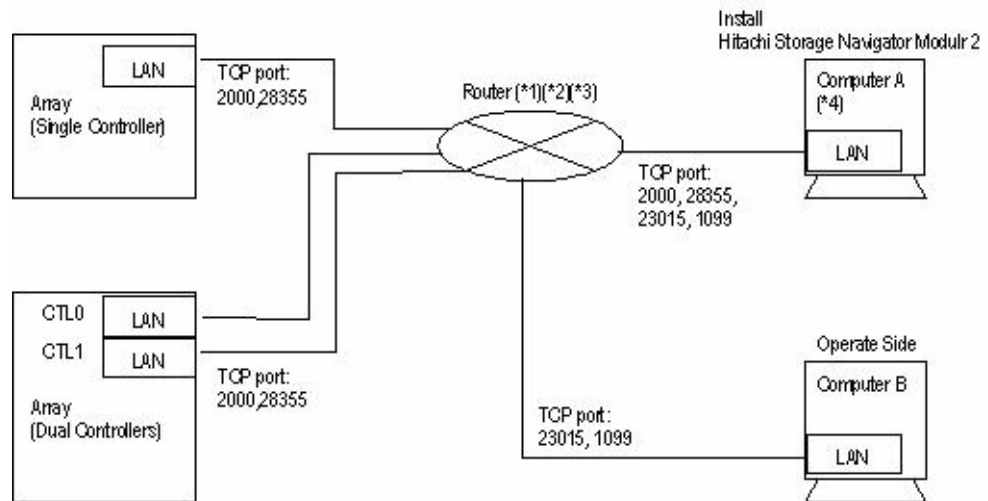
**Figure 10-1: Sample Configuration 1**

In this configuration:

- The storage system uses 2000/tcp and 28355/tcp to communicate with Navigator 2. If the storage system is connected directly to a computer, but cannot communicate through the router, the router can have blocked ports. In this case, configure the router to permit 2-way communication to ports.
- IPv6 multicasting is used on the local link to search for the storage system's IPv6 address. Prior to having Navigator 2 search for the storage system, configure the storage system and the computer in which Navigator 2 is installed to reside on the same link.
- If the computer where Navigator 2 is installed has two or more NICs connected to separate network segments, Navigator 2 can only access the LAN whose addresses were specified when Navigator 2 was installed.

## Example 2

Figure 10-2 on page 10-7 shows a configuration where a computer with Navigator 2 and another computer are configured with different IPv6 addresses.



**Figure 10-2: Sample Configuration 2**

In this configuration:

- The storage system uses 2000/tcp and 28355/tcp to communicate with Navigator 2. If the computer is connected directly to the storage system, but cannot communicate through the router, the router can have blocked ports. In this case, configure the router to permit 2-way communication to ports.
- The computer in which Navigator 2 is installed (Computer A) uses 23015/tcp and 1099/tcp to communicate with Computer B. If Computer A can be connected directly to the storage system, but cannot communicate through the router, the router can have blocked ports. In this case, configure the router to permit 2-way communication to ports.
- IPv6 multicasting is used on the local link to search for the storage system's IPv6 address. Prior to having Navigator 2 search for the storage system, configure the storage system and the computer in which Navigator 2 is installed to reside on the same link.
- If the computer where Navigator 2 is installed has two or more NICs connected to separate network segments, Navigator 2 can only access the LAN whose addresses were specified when Navigator 2 was installed.

## Using secure sockets layer

If security is a concern, your management console can communicate with Navigator 2 using the Secure Sockets Layer (SSL) protocol. SSL ensures secure transactions between Navigator 2 and your management console's Web browser. The protocol uses a third party, a Certificate Authority (CA), to identify one end or both end of the transactions. The following steps summarize how SSL works.

1. A browser requests a secure page (usually https://).
2. Navigator 2 sends its public key with its certificate.

3. The browser checks that the certificate was issued by a trusted party (usually a trusted root CA), that the certificate is still valid and that the certificate is related to the site contacted.
4. The browser uses the public key to encrypt a random symmetric encryption key and sends it to the server with the encrypted URL required as well as other encrypted http data.
5. Navigator 2 decrypts the symmetric encryption key using its private key and uses the symmetric key to decrypt the URL and http data.
6. Navigator 2 sends back the requested html document and http data encrypted with the symmetric key.
7. The browser decrypts the http data and HTML document using the symmetric key and displays the information.

## Setting the certificate and private key

We recommend that you use a server certificate and private key for SSL communications with Navigator 2. The following sections describe how to create and set the server certificate and private key.

### Stopping the Navigator 2 service or daemon process

The first step when setting the certificate and private key for SSL communications is to stop the Navigator 2 service on Windows operating systems or to stop the Navigator 2 daemon process on Solaris and Linux operating systems. For more information, see [Starting or stopping the Navigator 2 service or daemon process on page 10-15](#).

### Creating a private key

The next step is to create a private key. Please refer to the appropriate section for your operating system.

#### Creating a private key on Windows

To create a private key on a Windows operating system:

1. Create the directory where the private key will be output.
2. Open a command prompt and go to the following directory:  
*<Navigator 2 installation directory>\Base\bin*
3. Type the following command line. The slanted text indicates a bit length for the key of 512, 1024, or 2048.

```
hcmdssslc genrsa -out c:\ca\httpsdkey.pem <bit length of key>
```

The following shows an example of issuing this command line:

```
hcmdssslc genrsa -out c:\ca\httpsdkey.pem 2048
Loading 'entropy' into random state - unable to load 'random state'
warning, not much extra random data, consider using the -rand option
Generating 2 prime RSA private key, 2048 bit long modulus
.....++
+++
.....+++++
e is 65537 (0x10001)
```

4. Type the following command line to create a certificate signing request (CSR):

```
hcmdssslc req -config C:\Program
Files\HiCommand\Base\httpsd\ssl\bin\demoCA\ssl.cnf
-new -key c:\ca\httpsdkey.pem -out c:\ca\httpsd.csr
```

5. Submit the created CSR file (httpsd.csr in the above example) to the  
The following shows an example of issuing this command line:

```
Using configuration from C:\Program
Files\HiCommand\Base\httpsd\ssl\bin\demoCA\
ssl.cnf
You will be prompted to enter information to incorporate
into the certificate request.
This information is called a Distinguished Name or a DN.
There are many fields however some can remain blank.
Some fields have default values.
Enter '.', to leave the field blank.
-----
Country Name (2 letter code) []:us
State or Province Name (full name) []:California
Locality Name (eg, city) []:San Jose
Organization Name (eg, company) []:Hitachi
Organizational Unit Name (eg, section) []:Hitachi
Common Name (eg, YOUR name) []:Hitachi
Email Address []:

Please enter the following 'extra' attributes
to be sent with your certificate request
A challenge password []:
An optional company name []:
```

6. Submit the created CSR file (httpsd.csr in the above example) to the CA and obtain the signed certificate.



**NOTE:** If you do not submit the CSR file to or obtain the signed certificate file from the CA, you can still create the certificate file with your signature using the `hcmdssslc` command. However, a warning window appears when the initial Navigator 2 window and subsequent window appear.

7. To create a self-signed certificate file, type the following command line:

```
hcmdssslc x509 -in c:\ca\httpsd.csr -out c:\ca\newcert.pem -reg -signkey  
c:\ca\httpsdkey.pem -days 365
```

```
c:\ca\httpsd.csr: CSR to CA  
c:\ca\newcert.pem: self-signed certificate  
c:\ca\httpsdkey.pem: key file
```

8. Using a text editor, open the file `httpsd.conf` in `<installation directory>\Base\httpsd\conf`.
9. Delete the hash sign (`#`) from the following slanted lines, which are commented out by default. Change the values of `SSLCertificateFile` and `SSLCertificateKeyFile`:
- For `SSLCertificateFile`, specify the signed certificate file obtained from the CA.
  - For `SSLCertificateKeyFile`, specify the full path of the private key file created earlier in this procedure.

The contents of the file are shown below:

```
SSLSessionCacheSize 0  
#Listen 23016  
#Listen [::]:23016  
#<VirtualHost slj-orca2xp:23016>  
# ServerName slj-orca2xp  
# SSLEnable  
# SSLProtocol SSLv3 TLSv1  
# SSLRequireSSL  
# SSLCertificateFile "C:/ca/httpsd.pem"  
# SSLCertificateKeyFile "C:/ca/httpsdkey.pem"  
# SSLCACertificateFile "C:/Program #Files/HiCommand/Base/httpsd/  
conf/ssl/cacert/anycert.pem"  
# SSLSessionCacheTimeout 3600  
#</VirtualHost>
```

10. Start the service for Navigator 2 (see [Starting the Navigator 2 server service or daemon process on page 10-20](#)).
11. Start the service for Hitachi Storage Command Suite Common Components (see [Starting the Hitachi Storage Command Suite common components on page 10-19](#)).
12. If there are other products that use the Hitachi Storage Command Suite Common Components, start the daemon process for those applications (refer to the documentation for those applications).

## Creating a private key on Solaris or Linux

To create a private key on a Solaris or Linux operating system:

1. Create the directory where the private key will be output.
2. Open a command prompt and go to the following directory:  
<Navigator 2 installation directory>/Base/httpsd/ssl/bin
3. Type the following command line. The slanted text indicates a bit length for the key of 512, 1024, or 2048.

```
ssl genrsa -out /ca/httpsdkey.pem <bit length of key>
```

The following shows an example of issuing this command line:

```
hcmdssl genrsa -out c:\ca\httpsdkey.pem 2048
Loading 'entropy' into random state - unable to load 'random state'
warning, not much extra random data, consider using the -rand option
Generating 2 prime RSA private key, 2048 bit long modulus
.....++
+++
.....+++++
e is 65537 (0x10001)
```

4. Type the following command line to create a certificate signing request (CSR):

```
./ssl req -config /opt/HiCommand/Base/httpsd/ssl/bin/
demoCA/ssl.cnf
```

```
-new -key ca/httpsdkey.pem -out /ca/httpsd.csr
```

The following shows an example of the result from executing this command line:

```
Using configuration from C:\Program
Files\HiCommand\Base\httpsd\ssl\bin\demoCA\
ssl.cnf
You will be prompted to enter information to incorporate
into the certificate request.
This information is called a Distinguished Name or a DN.
There are many fields however some can remain blank.
Some fields have default values.
Enter '.', to leave the field blank.
-----
Country Name (2 letter code) []:us
State or Province Name (full name) []:California
Locality Name (eg, city) []:San Jose
Organization Name (eg, company) []:Hitachi
Organizational Unit Name (eg, section) []:Hitachi
Common Name (eg, YOUR name) []:Hitachi
Email Address []:

Please enter the following 'extra' attributes
to be sent with your certificate request
A challenge password []:
An optional company name []:
```

5. Submit the created CSR file (`httpsd.csr` in the above example) to the CA and obtain the signed certificate.



**NOTE:** If you do not submit the CSR file to or obtain the signed certificate file from the CA, you can still create the certificate file with your signature using the `hcmdsslc` command. However, a warning window appears when the initial Navigator 2 window and subsequent window appear.

6. To create a self-signed certificate file, type the following command line:

```
./sslc x509 -in /ca/httpsd.csr -out /ca/newcert.pem -reg -signkey  
/ca/httpsdkey.pem -days 365
```

7. Using a text editor, open the file `httpsd.conf` in `<installation directory>\Base\httpsd\conf`.
8. Delete the hash sign (`#`) from the following slanted lines, which are commented out by default. Change the values of `SSLCertificateFile` and `SSLCertificateKeyFile`:
  - a. For `SSLCertificateFile`, specify the signed certificate file obtained from the CA.
  - b. For `SSLCertificateKeyFile`, specify the full path of the private key file created earlier in this procedure.

The contents of the file are shown below:

```
SSLSessionCacheSize 0  
#Listen 23016  
#Listen [::]:23016  
#<VirtualHost slj-orca2xp:23016>  
#  ServerName slj-orca2xp  
#  SSLEnable  
#  SSLProtocol SSLv3 TLSv1  
#  SSLRequireSSL  
#  SSLCertificateFile "C:/ca/httpsd.pem"  
#  SSLCertificateKeyFile "C:/ca/httpsdkey.pem"  
#  SSLCACertificateFile "C:/Program #Files/HiCommand/Base/httpsd/  
conf/ssl/cacert/anycert.pem"  
#  SSLSessionCacheTimeout 3600  
#</VirtualHost>
```

9. Start the daemon process for Navigator 2 (see [Starting the services or daemon process on page 10-18](#)).
10. Start the daemon process for Hitachi Storage Command Suite Common Components (see [Starting the Hitachi Storage Command Suite common components on page 10-19](#)).
11. If there are other products that use the Hitachi Storage Command Suite Common Components (HSCSCC), start the daemon process for those applications (refer to your HSCSCC Command Reference, User's and Installation Guides for those applications).

## Changing the IP Address for connecting to Navigator 2

If you need to change the IP address you use to connect to Navigator 2, perform the following procedure.

1. Stop the Navigator 2 Server service or daemon process (see [Starting or stopping the Navigator 2 service or daemon process on page 10-15](#)).
2. If other products are using Hitachi Storage Command Suite Common Components:
  - Stop those products.
  - Stop the service or daemon process (see [Stopping Hitachi Storage Command Suite common components on page 10-17](#)).
3. Using one of the following steps, edit the setting file `snmserver.properties` and change the connection address. (The slanted text in the following command lines indicates the directory where the Hitachi Storage Command Suite Common Components are installed).

For Windows, `jp.co.Hitachi.strdiskarray.rmi.hostname` in the file `C:\Program Files\HiCommand\StorageNavigatorModular\server\snmserver.properties` specifies the connection address. Change the address in this file to the address you want to use.

For Solaris and Linux, `jp.co.Hitachi.strdiskarray.rmi.hostname` in the file `/opt/HiCommand/StorageNavigatorModular/server/snmserver.properties` specifies the connection address. Change the address in this file to the address you want to use.

Example: `jp.co.Hitachi.strdiskarray.rmi.hostname=192.168.0.1`

4. Start the service or daemon process for the Hitachi Storage Command Suite Common Components (see [Starting the Hitachi Storage Command Suite common components on page 10-19](#)).
5. Start the Navigator 2 service or daemon process (see [Starting or stopping the Navigator 2 service or daemon process on page 10-15](#)).
6. If there are other products that use the Hitachi Storage Command Suite Common Components, start the service or daemon process for those applications (refer to the documentation for those applications).

## Changing the Default Port Number for Navigator 2

By default, Navigator 2 uses the port number 23015. If you need to change this port number, use the following procedure.



---

**NOTE:** Changing the port number used by Hitachi Storage Command Suite Common Components affects all installed products that use these components. Therefore, before you change the default port number, be sure that this change will not adversely affect the products that use Hitachi Storage Command Suite Common Components.

---

1. Stop the Navigator 2 Server service or daemon process (see [Starting or stopping the Navigator 2 service or daemon process on page 10-15](#)).
2. If other products are using Hitachi Storage Command Suite Common Components:
  - Stop those products.
  - Stop the service or daemon process (see [Stopping Hitachi Storage Command Suite common components on page 10-17](#)).
3. Use one of the following steps to change the port number in the file `httpsd.conf`. (The slanted text in the following command lines indicates the directory where the Hitachi Storage Command Suite Common Components are installed.)

For Windows, the `listen` setting in the file `C:\Program Files\HiCommand\Base\httpsd\conf\httpsd.conf` file specifies the port number. Change this number to the port number you want to use.

For Linux and Solaris, the `listen` setting in the file `/opt/HiCommand/Base/httpsd/conf/httpsd.conf` specifies the port number. Change this number to the port number you want to use.

Example: `Listen 23015`

4. Start the service or daemon process for the Hitachi Storage Command Suite Common Components (see [Starting the Hitachi Storage Command Suite common components on page 10-19](#)).
5. Start the Navigator 2 service or daemon process (see [Starting or stopping the Navigator 2 service or daemon process on page 10-15](#)).
6. If there are other products that use the Hitachi Storage Command Suite Common Components, start the service or daemon process for those applications (refer to the documentation for those applications).

## Starting or stopping the Navigator 2 service or daemon process

If you install Navigator 2 in Windows, Hitachi Storage Command Suite Common Components and the Navigator 2 Server are registered in the operating system as services. If you install Navigator 2 in Solaris and Linux, start and stop scripts of the process created below `/etc/init.d` and the Hitachi Storage Command Suite Common Components and Navigator 2 Server execute automatically as daemon processes when these applications start.

Because the status of the services or daemon processes are registered as start, starting the operating system automatically starts the services or daemons. If you perform the following operations, however, you must stop, start, or restart the services or daemon process of the Hitachi Storage Command Suite Common Components and Navigator 2 Server.

- Update the Navigator 2 installation
- Uninstall Navigator 2
- Install products other than Navigator 2 that use Hitachi Storage Command Suite Common Components
- Uninstall products other than Navigator 2 that use Hitachi Storage Command Suite Common Components
- Change Navigator 2 setting files
- If you must stop or start the service or daemon process to use Hitachi Storage Command Suite Common Components while another product is in use

When the service or daemon process stops, you cannot use Navigator 2 and other products that use Hitachi Storage Command Suite Common Components. Before stopping the service or daemon process, therefore, be sure that:

- No users are using Navigator 2.
- There will be no problem if error monitoring is disabled temporarily.
- Storage system firmware is not being or will not be updated.
- You refer to the documentation for applications that use the services or daemon processes to determine whether they will be adversely affected if stopped.

## Stopping the services or daemon processes

To stop the services or daemon process, use the following procedure.

1. Stop the Navigator 2 Server service or daemon process.
2. Stop the service or daemon process for the Hitachi Storage Command Suite Common Components.
3. Refer to the documentation for any products that use Hitachi Storage Command Suite Common Components to see whether the services or daemon processes for those applications must be stopped as well.

## Stopping the Navigator 2 server service or daemon process

### Windows operating systems

There are two ways to stop Navigator 2 Server on a Windows operating system:

- A graphical method
- A command prompt method

To use the graphical method, perform the following procedure.

1. In the Windows **Start** menu, click **Settings > Control Panel**.
2. In the Control Panel, double-click **Administrative Tools**.
3. Double-click **Services**.
4. In the **Services (Local)** list, right-click the **SNM2 Server** and click **Stop** from the shortcut menu.

To use the command prompt method, perform the following procedure.

1. In the Windows Start menu, click **Programs > Accessories > Command Prompt**.
2. At the command prompt, enter the following command and press the Enter key.

```
C:\> net stop snm2server
```

Any directory can be the current directory when issuing the command.

### Solaris and Linux operating systems

To stop the Navigator 2 Server daemon process on Solaris and Linux operating systems, issue the following command line.

```
/etc/init.d/snm2srv stop
```

Note that root authority is required to execute the command and that Any directory can be the current directory when issuing the command.

# Stopping Hitachi Storage Command Suite common components

## Windows operating systems

To stop the Hitachi Storage Command Suite Common Components service on Windows operating systems, used the following procedure.

1. In the Windows **Start** menu, click **Programs > Accessories > Command Prompt**.
2. In the command prompt, move to the directory where the Hitachi Storage Command Suite Common Components are installed.

```
C:\> cd /D C:\Program Files\HiCommand\Base\bin
```

3. In the directory where the Hitachi Storage Command Suite Common Components are installed, issue the following command line and press Enter.

```
C:\Program Files\HiCommand\Base\bin>hcmdssrv /stop
```

It can take several minutes to stop the service.

4. Issue the following command line to check that the service stopped.

```
C:\Program Files\HiCommand\Base\bin>hcmdssrv /status
```

The underlined part of the command C:\Program Files\HiCommand is the path to the folder where Hitachi Storage Command Base Common Components are installed. Revise this line according to the path where these components reside in your installation.

- If the only product that uses Hitachi Storage Command Suite Common Components is Navigator 2, this folder is the one where Navigator 2 was installed.
- If other products use Hitachi Storage Command Suite Common Components, specify a folder that was specified when the first product was installed.

Do not directly stop the service of Hitachi Storage Command Suite Common Components using the Services window of the Control Panel or the `netstop` command. Otherwise, Hitachi Storage Command Suite Common Components can become unusable.

## Solaris and Linux operating systems

To stop the Hitachi Storage Command Suite Common Components service on Solaris and Linux operating systems, used the following procedure

1. Issue the following command line. Root authority is required to execute the command. Any directory can be the current directory when issuing the command.

```
/opt/HiCommand/Base/bin/hcmdssrv -stop
```

It can take several minutes to stop the daemon process.

2. Issue the following command line to check that the daemon process stopped.

```
/opt/HiCommand/Base/bin/hcmdssrv -status
```

The underlined part of the command /opt/HiCommand is the path to the folder where Hitachi Storage Command Base Common Components are installed. For Linux, revise this line according to the path where these components reside in your installation.

- If the only product that uses Hitachi Storage Command Suite Common Components is Navigator 2, this directory is `/opt/HiCommand`. Solaris users do not have to replace `/opt/HiCommand`.
- If other products use Hitachi Storage Command Suite Common Components, specify a folder that was specified when the first product was installed.

Do not directly stop the service of Hitachi Storage Command Suite Common Components using the script below `/etc/init.d` or by sending a signal with the `kill` command. Otherwise, Hitachi Storage Command Suite Common Components can become unusable.

## Starting the services or daemon process

To start the services or daemon process:

1. Start the service or daemon process for the Hitachi Storage Command Suite Common Components.
2. Start the Navigator 2 Server service or daemon process.
3. Refer to the documentation for any products that use Hitachi Storage Command Suite Common Components to see whether the services or daemon processes for those applications must be started as well.

# Starting the Hitachi Storage Command Suite common components

## Windows operating systems

To start the Hitachi Storage Command Suite Common Components service on Windows operating systems, perform the following procedure.

1. In the Windows **Start** menu, click **Programs > Accessories > Command Prompt**.
2. In the command prompt, move to the directory where the Hitachi Storage Command Suite Common Components are installed.

```
C:\> cd /D C:\Program Files\HiCommand\Base\bin
```

3. In the directory where the Hitachi Storage Command Suite Common Components are installed, issue the following command line and press Enter.

```
C:\Program Files\HiCommand\Base\bin>hcmdssrv /start
```

It can take several minutes to start the service.

4. Issue the following command line to check that the service started.

```
C:\Program Files\HiCommand\Base\bin>hcmdssrv /status
```

The underlined part of the command C:\Program Files\HiCommand is the path to the folder where Hitachi Storage Command Base Common Components are installed. Revise this line according to the path where these components reside in your installation.

- If the only product that uses Hitachi Storage Command Suite Common Components is Navigator 2, this folder is the one where Navigator 2 was installed.
- If other products use Hitachi Storage Command Suite Common Components, specify a folder that was specified when the first product was installed.

Do not directly start the service of Hitachi Storage Command Suite Common Components using the Services window of the Control Panel or the `net start` command. Otherwise, Hitachi Storage Command Suite Common Components can become unusable

## Solaris and Linux operating systems

To start the Hitachi Storage Command Suite Common Components daemon process, perform the following procedure.

1. Issue the following command. Root authority is required to execute the command. Any directory can be the current directory when issuing the command

```
/opt/HiCommand/Base/bin/hcmdssrv -start
```

It can take several minutes to start the daemon process. Check that the daemon process is started by executing the following command.

It can take several minutes to start the daemon process.

2. Issue the following command line to check that the daemon process started.

```
/opt/HiCommand/Base/bin/hcmdssrv -status
```

The underlined part of the command `/opt/HiCommand` is the path to the folder where Hitachi Storage Command Base Common Components are installed. For Linux, revise this line according to the path where these components reside in your installation.

- If the only product that uses Hitachi Storage Command Suite Common Components is Navigator 2, this directory is `/opt/HiCommand`. Solaris users do not have to replace `/opt/HiCommand`.
- If other products use Hitachi Storage Command Suite Common Components, specify a folder that was specified when the first product was installed.

Do not directly start the service of Hitachi Storage Command Suite Common Components using the script below `/etc/init.d` or by sending a signal with the `kill` command. Otherwise, Hitachi Storage Command Suite Common Components can become unusable.

## Starting the Navigator 2 server service or daemon process

### Windows operating systems

There are two ways to start Navigator 2 Server on a Windows operating system:

- A graphical method
- A command prompt method

To use the graphical method, perform the following procedure.

1. In the Windows **Start** menu, click **Settings > Control Panel**.
2. In the Control Panel, double-click **Administrative Tools**.
3. Double-click **Services**.
4. In the **Services (Local)** list, right-click the **SNM2 Server** and click **Start** from the shortcut menu.

To use the command prompt method, perform the following procedure.

1. In the Windows Start menu, click **Programs > Accessories > Command Prompt**.
2. At the command prompt, enter the following command and press the Enter key.

```
C:\> net start snm2server
```

Any directory can be the current directory when issuing the command.

## Solaris and Linux operating systems

To start the Navigator 2 Server daemon process on Solaris and Linux operating systems, issue the following command line. Root authority is required to execute the command. Any directory can be the current directory when issuing the command.

```
/etc/init.d/snm2srv start
```

## Using the SATA Write and Compare feature

Navigator 2 supports a SATA write and compare feature that ensures the integrity of data written to SATA drives. This feature is enabled by default and is only valid for SATA drives (SAS and SSD drives do not provide such capabilities).

When a host sends data to the storage system with the SATA write and compare feature enabled, the storage system:

- Stores the received data in cache memory.
- Sends the host an indication that the data has been received.
- Writes the received data to the SATA drives.

Following successful completion of the write operation, the storage system reads the data it just wrote and compares it against the same data in cache memory. If this check is successful, the cache data blocks are marked as available for new data. If there is a problem during this compare, the cached data is rewritten to the SATA drives once again.

Disabling the write and compare feature can provide slight gains in performance. However, in the unlikely event your storage system hangs or goes down before the write cache gets cleared, data can become lost or corrupted. While the data corruption can not be fatal, you could lose critical files permanently.

The following message appears:

**Warning!**

Disabling SATA Write & Compare increases the risk of data corruption if a drive fails. For this reason, Hitachi does not recommend disabling this feature for critical and non-replicated information.

Disabling SATA Write & Compare maybe appropriate for most other types of data, especially duplicated data. Make sure to evaluate the risks before disabling this feature.

Do you want to proceed with disabling SATA Write & Compare?

If you understand the potential risks of disabling the storage system's write and compare feature and decide to disable this feature, use the following procedure.

1. Start Navigator 2.

2. When the Arrays window appears, click the storage system whose SATA write and compare setting you want to view or change.
3. In the Arrays pane, click **Settings > SATA Write & Compare**. The SATA Write & Compare window appears, with the current SATA write and compare setting displayed.
4. To change the SATA write & compare setting:
  - a. Click the **Change SATA Write & Compare** button in the top-right area of the SATA Write & Compare window. The Change SATA Write & Compare window appears.
  - b. Select the desired setting:
    - Enable:** performs optimized read and verification for write operations to SATA volumes. Select this option to balance performance and reliability. This is the default setting.
    - Disable:** read and verification are not performed for write operations to SATA volumes. Select this option for maximum performance, but least reliability.
  - c. Click **OK**.
  - d. If you disabled SATA write and compare, the precautionary message appears. Check **Yes, I have read the above warning and agree to change SATA Write & Compare** and click **Confirm**.

When the confirmation message appears, click **Close**. to remove the message and complete the procedure. The SATA Write & Compare window reappears, with the current SATA write and compare setting displayed.

## User Account settings for HiCommand Device Manager and Navigator 2

This section provides guidelines about setting up user accounts properly in HiCommand Device Manager and Navigator 2 to manage the AMS 2000 Family storage systems successfully. Following the information in this section will let you avoid HiCommand Device Manager from inadvertently logging out users from Navigator 2.

### Overview

HiCommand Device Manager, Navigator 2, and other products such as HiCommand Tuning Manager all have accounts that are stored in a common component. Storing accounts in a single component allows these applications to be accessed from a single access point/URL.

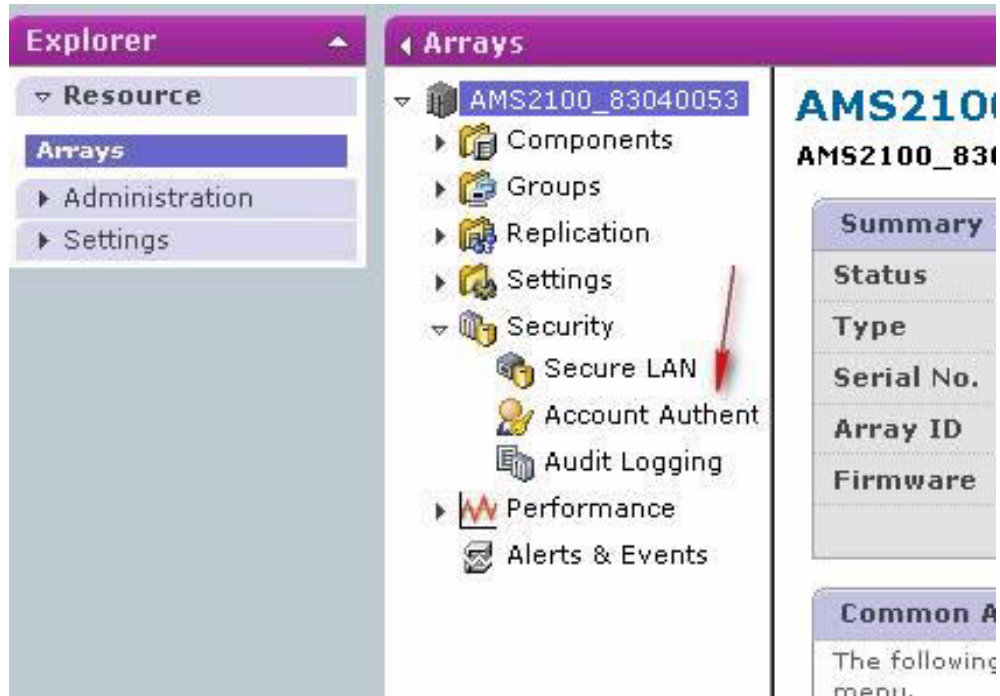
Array security or Account Authentication, however, is separate. As a result, you must create one unique account in Account Authentication whose account name does not match an existing account name in related Hitachi software products such as Device Manager, Navigator 2, and Tuning Manager. This unique account is only used to add the storage system within Device Manager. You will not use it to log into Device Manager, Navigator 2, Tuning Manager or other Hitachi software products. [Table 10-2](#) provides a summary of account types and conventions for account names.

**Table 10-2: Summary of Account Types and Conventions for Account Names**

Type of Account	Account Names			Comments
	Device Manager	Navigator 2	AMS 2000	
Default	system	system	root	These are the product defaults that users do not have to create. They are used only when starting the products. Their password should be changed, and a new, public (admin) account should be created and used for actually functioning as an administrator within the product.
Public/Admin	admin4hds	admin4hds	n/a	<p>To be created by users. admin4hds is an example of an account name. In this case, <b>admin4hds</b> must exist in both Device Manager and Navigator 2 so they can communicate.</p> <p>The Device Manager user (i.e., the user logged in as <b>admin4hds</b>) must have Navigator 2 modify privileges assigned to him in Navigator 2 to get cooperative Navigator 2 functionality (drop-down menus) in Device Manager-MC (main console) for the AMS 2000 Family storage system.</p>
Account Authentication for storage system admin	n/a	n/a	AddArray or adminAMS2500 or bsmith	<p>The account name <b>AddArray</b> is created on the AMS 2000 Family storage system. A user logs into Navigator 2, registers an AMS 2000 Family storage system, and creates this account name on the AMS 2000 Family storage system. This particular account name is created on the storage system solely for the purpose of adding it into Device Manager.</p> <p>To administer and manage the storage system, create a different account name such as <b>adminAMS2500</b>, <b>bsmith</b>, etc.</p>

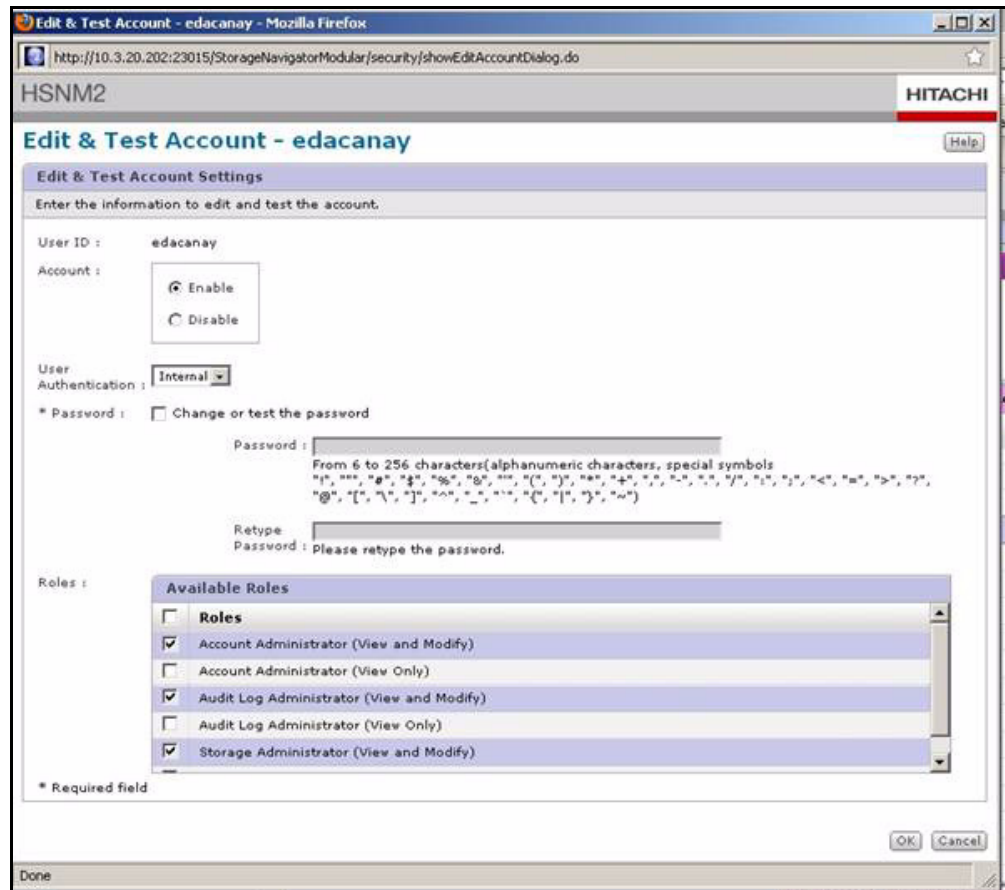
## Example of using the different account types

Figure 10-3 shows a user is logged in to Navigator 2 as **admin4hds** to access the storage system using Account Authentication.

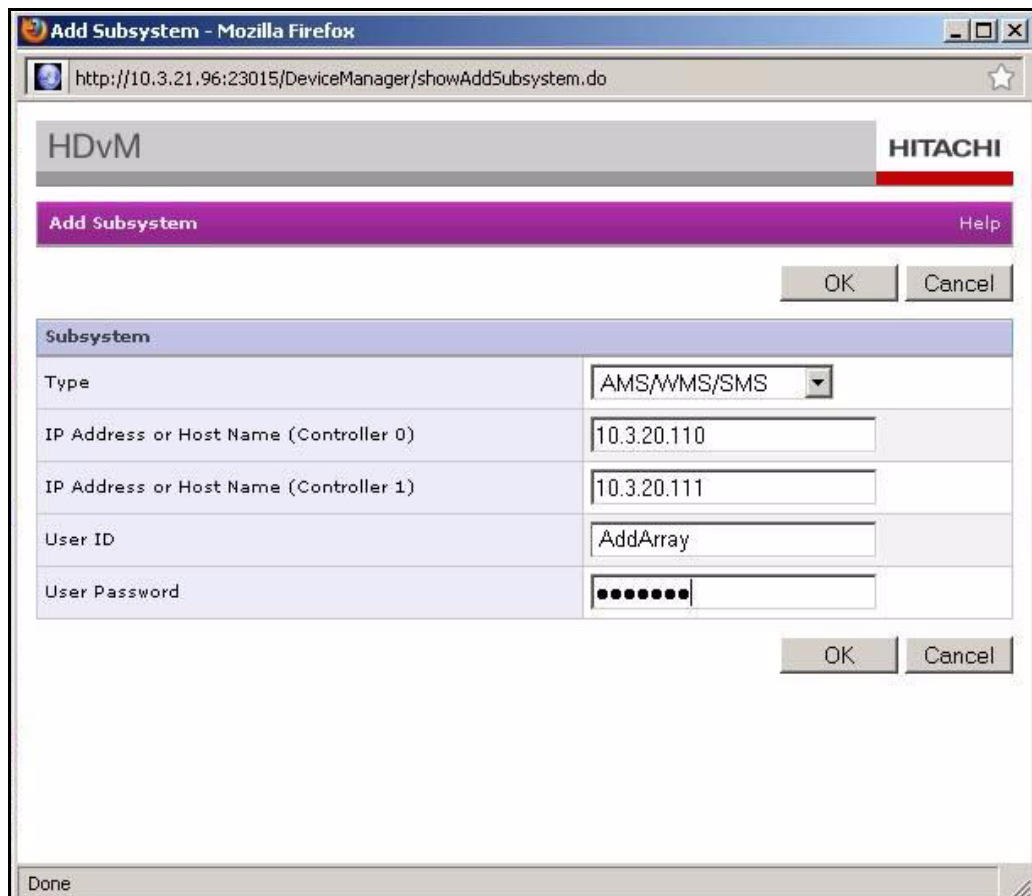


**Figure 10-3: Accessing the Storage System Using Account Authentication**

Next, an Account Authentication user called **AddArray** was created on the AMS 2000 Family storage system. All three view and modify rights must be assigned to this user.



Finally, log into Device Manager using **system/manager** (or **admin4hds** and its password), add the storage system, and enter the **AddArray** credentials in the Add Arrays window.



In this scenario, the unique **AddArray** account on the AMS 2000 Family storage system is used solely for coordinating with Device Manager when adding the storage system in Device Manager. For managing an AMS 2000 Family storage system, create a different account on the storage system, such as **adminAMS2500** or **bsmith**.



# Troubleshooting

In the unlikely event you encounter a problem installing, configuring, or using Navigator 2, refer to the troubleshooting suggestions in this chapter to identify and resolve the problem.

The topics covered in this chapter are:

- [If the Installation Fails on a Windows Operating System](#)
- [Collecting Trace Information](#)
- [Firmware Troubleshooting](#)
- [List of Failure Codes](#)

## If the Installation Fails on a Windows Operating System

Data Execution Prevention (DEP) is a Windows security feature intended to prevent an application or service from executing code from a non-executable memory region. DEP perform checks on memory to prevent malicious code or exploits from running on the system by shut down the process once detected. However, DEP can accidentally shut down legitimate processes, like your Navigator 2 installation.

If your management console runs Windows Server 2003 SP1 or Windows XP SP2 or later, and your Navigator 2 installation fails, disable DEP.

1. Click **Start**, and then click **Control Panel**.
2. Click **System**.
3. In the System Properties window, click the **Advanced** tab.
4. In the **Performance** area, click **Settings** and then click the **Data Execution Prevention** tab.
5. Click **Turn on DEP for all programs and services except those I select**.
6. Click **Add** and specify the Navigator 2 installer `HSNM2-xxxx-W-GUI.exe`, where `xxxx` varies with the version of Navigator 2. The Navigator 2 installer `HSNM2-xxxx-W-GUI.exe` is added to the list.
7. Click the checkbox next to the Navigator 2 installer `HSNM2-xxxx-W-GUI.exe` and click **OK**.

## Collecting Trace Information

When you contact Hitachi Technical Support for help with a problem you are having with the Hitachi AMS 2000 Family storage system, Technical Support might request that you collect trace and debug information using Navigator 2. To perform this task:

1. Log in to Navigator 2:

`http://<IP address of management console PC>:23015/StorageNavigatorModular/`

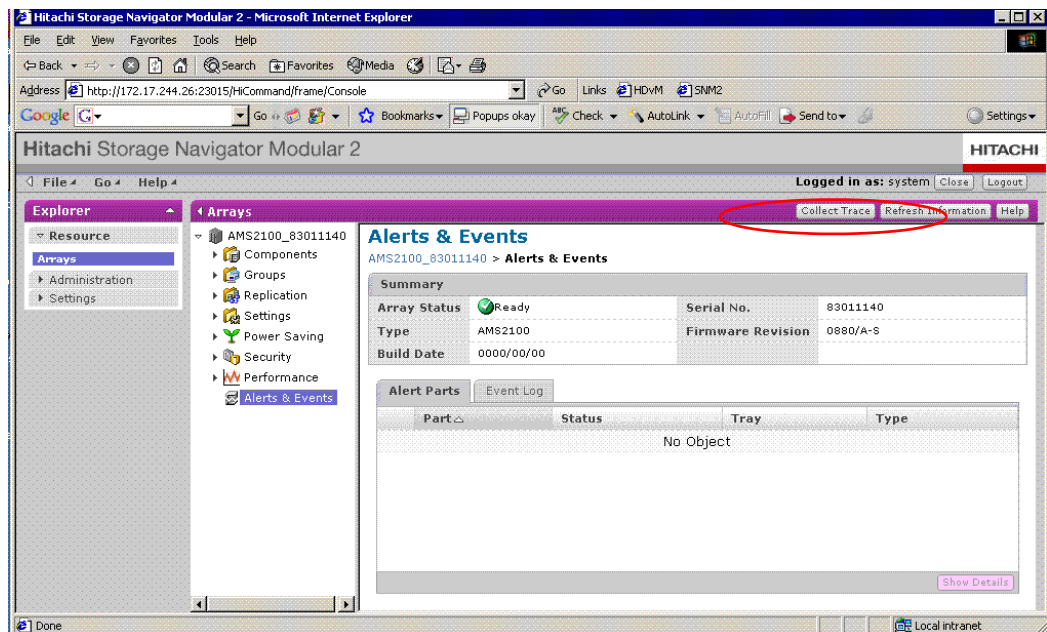
OR

`https://<IP address>:23016/StorageNavigatorModular/`



**NOTE:** If entering an IPv6 address in your Web browser, enter the URL in brackets. Example: `http://[xxxx]:23015/StorageNavigatorModular`

2. Go to the Explorer pane and click **Arrays**.
3. In the **Arrays** area, check the status and serial number of the storage system where the failure occurred (see [Figure 5-1 on page 5-3](#)).
4. Click the **Collect Trace** button at the top-right area of the Failure List window.



**Figure 11-1: Collect Trace Button**

# Firmware Troubleshooting

The following sections provide troubleshooting recommendations if you encounter a problem when upgrading the storage system firmware.

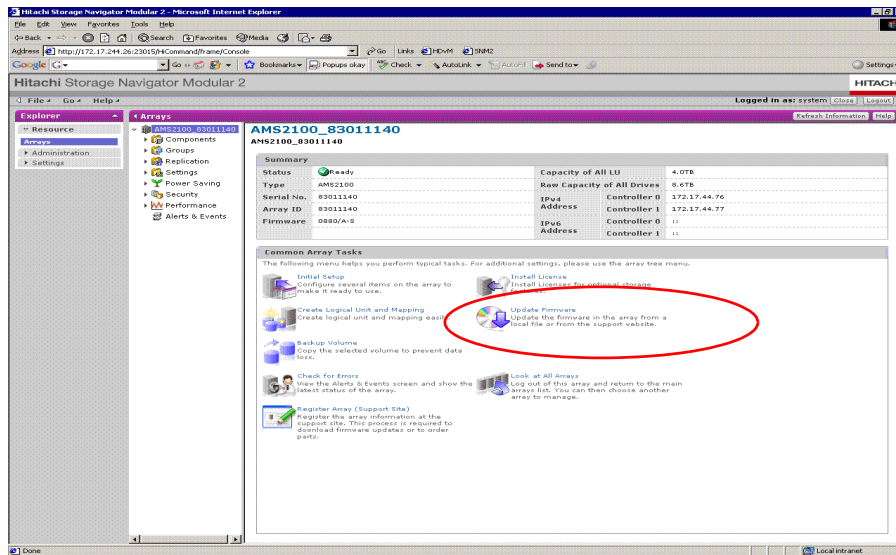
## DMES01EA05 Message Appears During Firmware Upgrade

If the following message appears during a firmware upgrade:

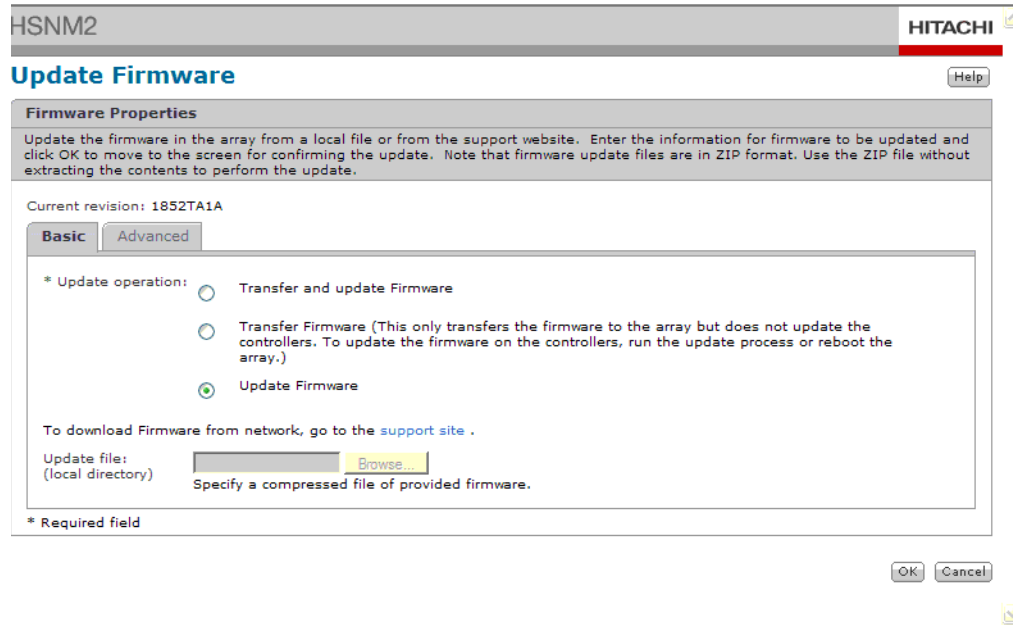
*DMES01EA05: The firmware has been downloaded to the system drives, but some system drives could not be used. The subsystem can be used.*

and the processing ends during the firmware update, the firmware update has not completed. If this happens:

1. Click **Update Firmware** under **Common Array Tasks** (see [Figure 11-2](#)).
2. When the Update Firmware window appears (see [Figure 11-3 on page 11-5](#)), select **Update Firmware** from the **Basic** tab, use the **Browse** button to select the downloaded firmware file, and click the **OK** button.
3. Follow the instructions in the next window that appears.



**Figure 11-2: Common Storage System Tasks Area with Update Firmware Circled**



**Figure 11-3: Update Firmware Window**

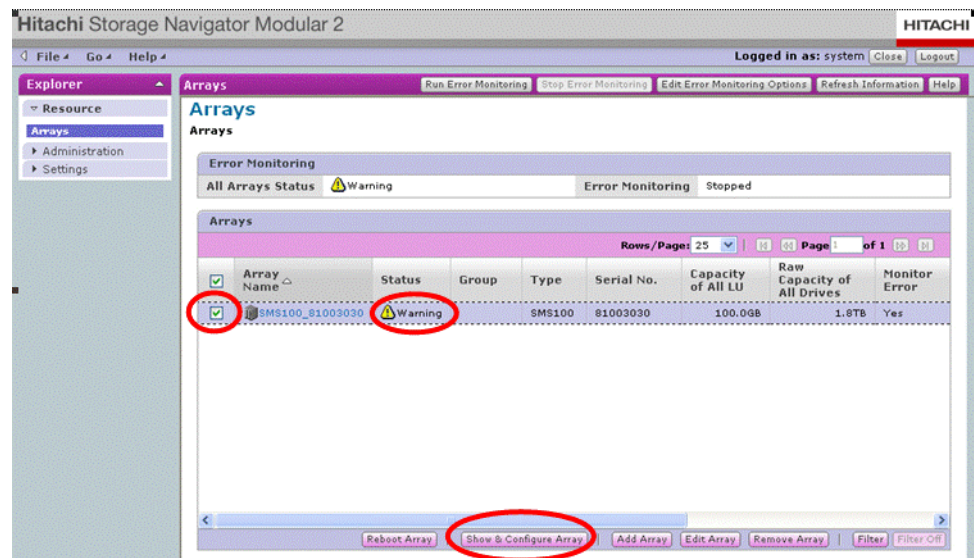
## Upgrading Firmware When the Storage System Has a Warning Status

If Navigator 2 shows that the storage system has a warning status (see [Figure 11-4](#)), use the following procedure to perform the firmware update procedure.



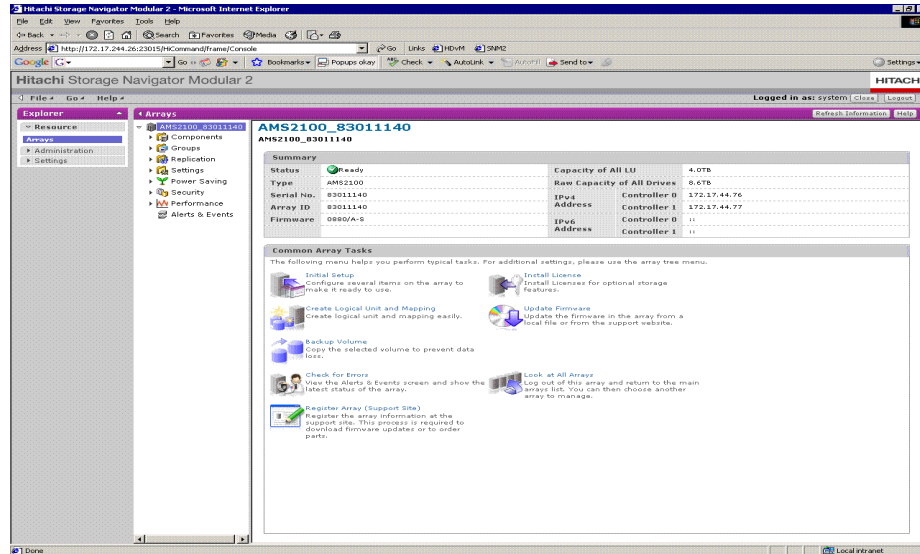
**NOTE:** This procedure requires all host I/O operations to stop.

1. Check the checkbox next to the storage system, as shown in [Figure 11-4](#), and click **Show & Configure Array**.

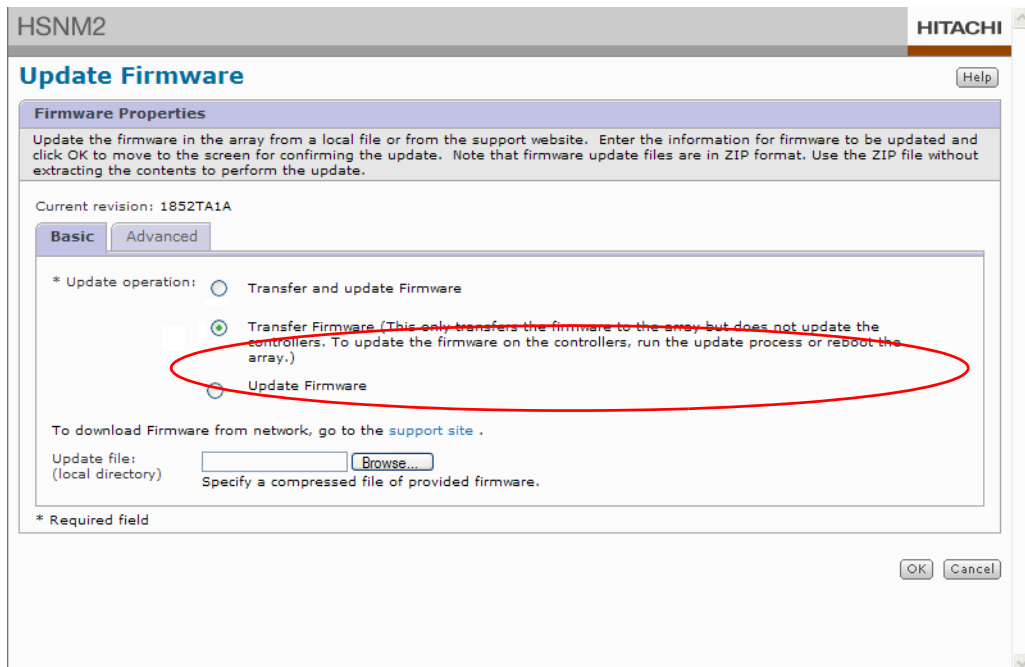


**Figure 11-4: Warning Status in Navigator 2**

2. Under **Common Array Tasks**, check the firmware version shown next to **Firmware** in the **Summary** area. The **A** in the firmware version indicates the firmware is for the Hitachi AMS 2000 Family storage system.
3. Click **Update Firmware** (see Figure 11-5). The Update Firmware window in Figure 11-6 appears.



**Figure 11-5: Common Storage System Tasks Area with Update Firmware Circled**



**Figure 11-6: Update Firmware Window**

4. Under **Update operation**, click **Transfer Firmware** (see Figure 11-6).

5. Click the **Browse** button next to **Update file** and select the firmware file.
6. Click **OK**. The Update Firmware confirmation window appears.
7. Read the information in the window. Then check **Yes, I have read the above warning and want to transfer the firmware**.
8. Click the **Confirm** button to proceed.
9. When a window indicates that the firmware has been transferred, click **Close** to close the window.
10. Stop all host I/O.
11. Power off the storage system, then power it on again.
12. Using Navigator 2, go to the Common Array Tasks and confirm that the firmware version shown in the **Summary** area is the one you installed (see [Figure 11-5 on page 11-6](#)).

## List of Failure Codes

In the unlikely event your storage system encounters a failure, Storage Navigator Modular 2 displays an Alarm Information window with a failure message, failure code, and, if appropriate, ordering information for a failed part. Each failure code begins with one of the following prefixes:

- WSA
- WSB
- WSC
- WSD

If you receive such an error code, please refer to [Table 11-1 on page 11-8](#).

**Table 11-1: Failure Codes**

<b>Failure Code Prefix</b>	<b>Content of Failure</b>
WSAxxx	Critical error occurred with the original tray. Please contact HDS Support at <a href="http://support.hds.com">support.hds.com</a> .
WSBxxx	Critical error occurred with the original tray. Please contact HDS Support at <a href="http://support.hds.com">support.hds.com</a> .
WSC10x	An error occurred with a SAS drive in the first spare drive slot. Please follow the instructions in the Alarm Information screen.
WSC11x	An error occurred with a SATA drive in the first spare drive slot. Please follow the instructions in the Alarm Information screen.
WSD10x	An error occurred with a SAS drive in the second spare drive slot. Please follow the instructions in the Alarm Information screen.
WSD11x	An error occurred with a SATA drive in the second spare drive slot. Please follow the instructions in the Alarm Information screen.



# Upgrading Navigator 2

This appendix describes how to upgrade the Navigator 2 software to a newer version on a host running one of the Navigator 2-supported operating systems.

The topics covered in this appendix are:

- [Before you start](#)
- [Upgrading Navigator 2 on Windows operating systems](#)
- [Upgrading Navigator 2 on Solaris operating systems](#)
- [Upgrading Navigator 2 on Linux operating systems](#)

## Before you start

If you will be upgrading Navigator 2 using a secure HTTPS connection, use the following procedure to set the server certificate and private key after completing the update.

1. Create the directory used to output a private key.
2. Stop the services for Navigator 2 and then stop the service of HiCommand Suite Common Components (see [Stopping Hitachi Storage Command Suite common components on page 10-17](#)).
3. Create a private key using the `hcmdssslc` command:
  - a. Open the command prompt (terminal console for Unix) and move to the following directory.

For Windows:

```
<Navigator 2 installation directory>\Base\bin
```

For Unix:

```
<Navigator 2 installation directory>/Base/httpsd/sslc/bin
```

- b. Issue the following command line. The underlined part indicates one of the following key bit lengths: 512, 1024, or 2048.

For Windows:

```
hcmdssslc genrsa -out c:\ca\httpsdkey.pem <key bit length>
```

For Unix:

```
sslc genrsa -out /ca/httpsdkey.pem <key bit length>
```

The following shows an execution example:

```
hcmdssslc genrsa -out c:\ca\httpsdkey.pem 2048
Loading 'entropy' into random state - unable to load 'random state'
warning, not much extra random data, consider using the -rand option
Generating 2 prime RSA private key, 2048 bit long modulus
.....+++++
.....+++++
e is 65537 (0x10001)
```

4. Create a Certificate Signing Request (CSR) by issuing the following command line:

For Windows:

```
hcmdssslc req -config C:\Program Files\HiCommand\Base\httpsd\
ssl\bin\demoCA\ssl.cnf
               -new -key c:\ca\httpsdkey.pem -out c:\ca\httpsd.csr
```

For Unix:

```
/ssl req -config /opt/HiCommand/Base/httpsd/ssl/bin/demoCA/ssl.cnf
         -new -key ca/httpsdkey.pem -out /ca/httpsd.csr
```

The following shows an execution example:

```
Using configuration from C:\Program
Files\HiCommand\Base\httpsd\ssl\bin\demoCA\
ssl.cnf
You will be prompted to enter information to incorporate
into the certificate request.
This information is called a Distinguished Name or a DN.
There are many fields however some can remain blank.
Some fields have default values.
Enter '.', to leave the field blank.
-----
Country Name (2 letter code) []:us
State or Province Name (full name) []:California
Locality Name (eg, city) []:San Jose
Organization Name (eg, company) []:Hitachi
Organizational Unit Name (eg, section) []:Hitachi
Common Name (eg, YOUR name) []:Hitachi
Email Address []:

Please enter the following 'extra' attributes
to be sent with your certificate request
A challenge password []:
An optional company name []:
```

- a. Submit the created csr file (httpsd.csr, in the above example) to the CA (Certificate Authority) and obtain the signed certificate.

Even if you do not submit the csr file or obtain the signed certificate file from the CA, you can correspond to SSL by creating the certificate file with your signature using the hcmdssslc (ssl for Unix) command. In this case, however, the warning window appears at the time of the initial window display of Navigator 2, and when the applet launches.

To create a self-signed certificate file, include the hcmdssslc command (ssl command for Unix) in the following command line:

### For Windows:

```
hcmdssslc x509 -in c:\ca\httpsd.csr -out c:\ca\newcert.pem -reg -signkey
c:\ca\httpsdkey.pem -days 365

c:\ca\httpsd.csr: CSR to CA
c:\ca\newcert.pem: self-signed certificate
c:\ca\httpsdkey.pem: key file
```

### For Unix:

```
./sslc x509 -in /ca/httpsd.csr -out /ca/newcert.pem -reg -signkey
/ca/httpsdkey.pem -days 365
```

5. Using a text editor, open the `httpsd.conf` file in *<installation directory>*\Base\httpsd\conf and edit it as follows:
  - a. Remove # from the following underlined lines, which are commented out by default, and change the values of `SSLCertificateFile` and `SSLCertificateKeyFile`.
  - b. Specify the signed certificate file obtained from the CA for `SSLCertificateFile` and the full path of the private key file created in step 3 for `SSLCertificateKeyFile`.

The contents of the file are shown below:

```
SSLSessionCacheSize 0
#Listen 23016
#Listen [::]:23016
#<VirtualHost slj-orca2xp:23016>
# ServerName slj-orca2xp
# SSLEnable
# SSLProtocol SSLv3 TLSv1
# SSLRequireSSL
# SSLCertificateFile "C:/ca/httpsd.pem"
# SSLCertificateKeyFile "C:/ca/httpsdkey.pem"
# SSLCACertificateFile "C:/Program #Files/HiCommand/Base/httpsd/conf/
ssl/cacert/anycert.pem"
# SSLSessionCacheTimeout 3600
#</VirtualHost>
```

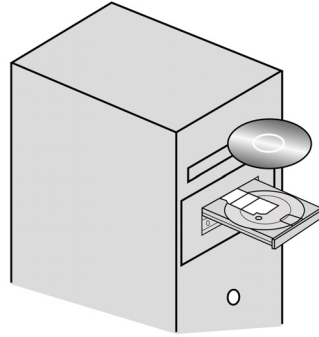
6. Start the Navigator 2 service and then start the service for the Hitachi Storage Command Suite Common Components (see [Stopping Hitachi Storage Command Suite common components on page 10-17](#)).

For instances where Navigator 2 shows the storage system has a warning status, see [Upgrading Firmware When the Storage System Has a Warning Status on page 11-5](#).

## Upgrading Navigator 2 on Windows operating systems

To upgrade Navigator 2 on a Navigator 2-supported Windows operating system, use the following procedure.

1. Insert the Hitachi Storage Navigator Modular 2 installation CD-ROM into the management console's CD/DVD-ROM drive.

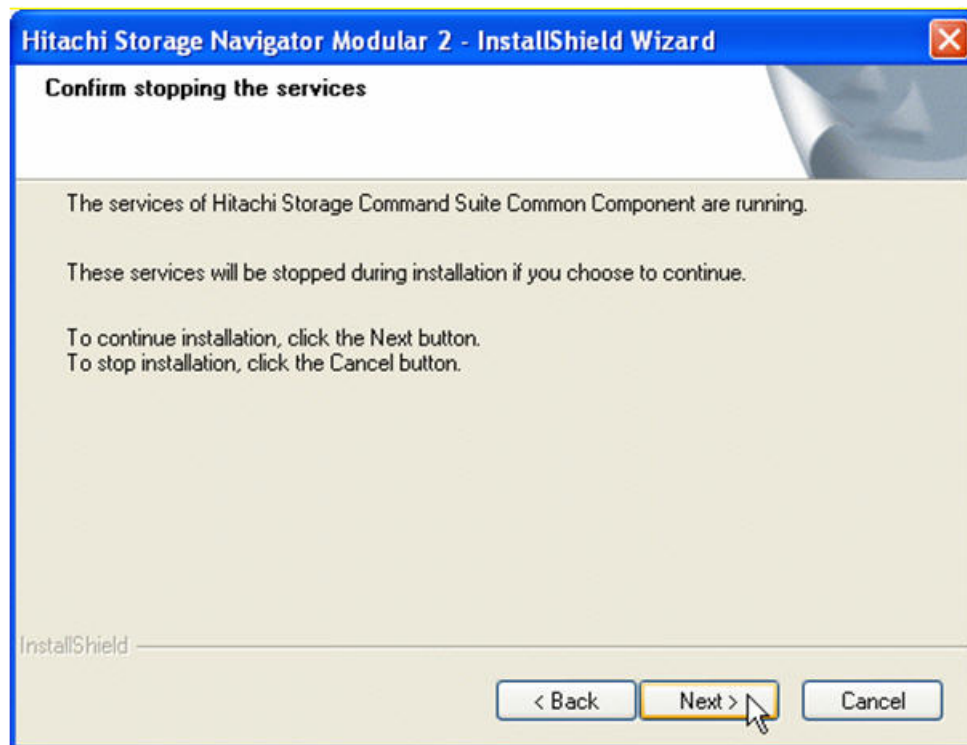


Installation starts automatically and the Welcome window appears.



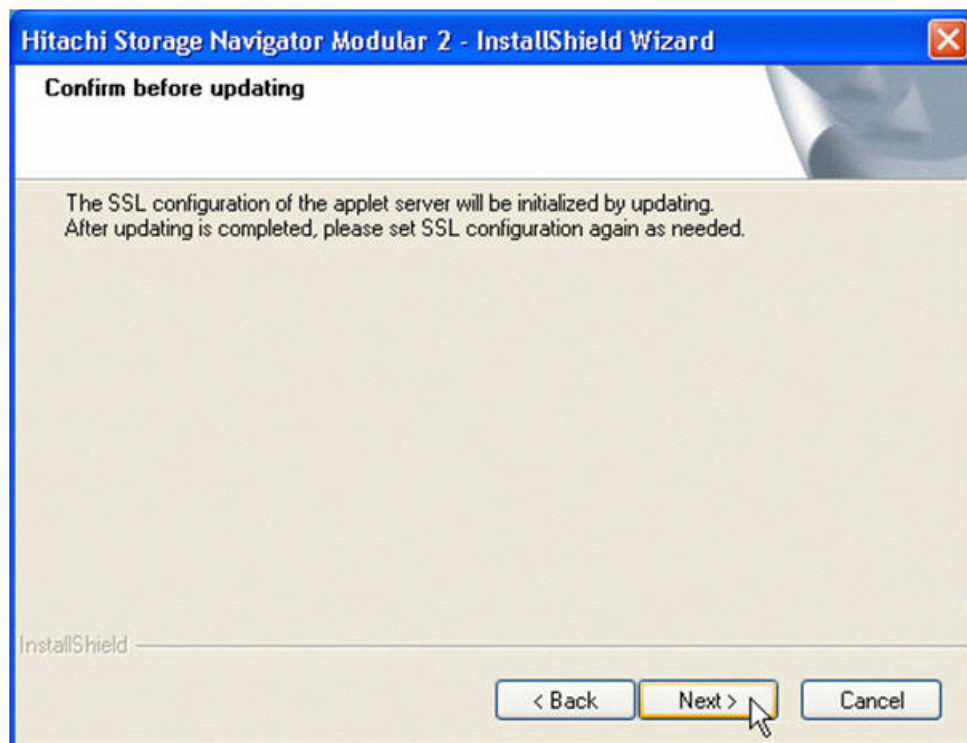
**Figure A-1: Navigator 2 Welcome Window**

2. Click **Next**. The Confirm stopping the services window appears.



**Figure A-2: Confirm stopping the services Window**

3. Click **Next**. The Confirm before updating window appears.



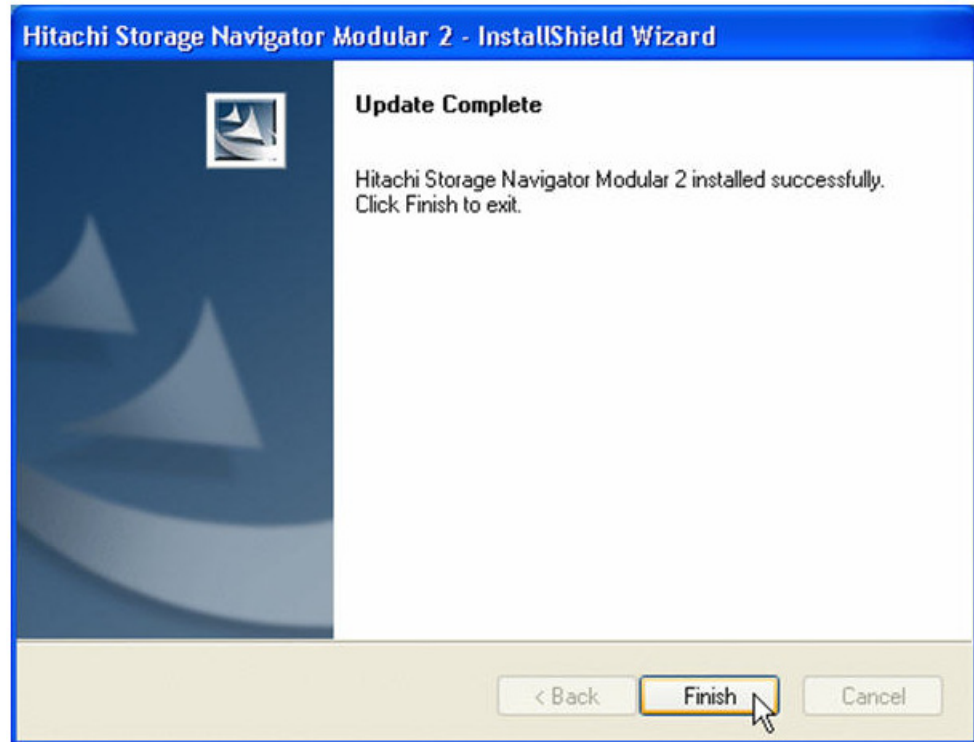
**Figure A-3: Confirm before updating Window**

4. Click **Next** to start the upgrade. Windows show the status of the upgrade. When the upgrade completes, the Update Complete window appears.



**NOTE:** You cannot stop the upgrade after it starts.

---



**Figure A-4: Update Complete Window**

5. Click **Finish** to complete the installation. You can now access Navigator 2 using a Web browser.

## Upgrading Navigator 2 on Solaris operating systems

To upgrade Navigator 2 on a Navigator 2-supported Solaris operating system, use the following procedure.

1. Insert the Navigator 2 installation CD-ROM in the computer's CD/DVD-ROM drive.
2. Mount the CD-ROM on the file system. The mount destination is `/cdrom`.



**NOTE:** If the host cannot read the CD-ROM, copy the files `install-hsnm2.sh` and `HSNM2-XXXX-S-GUI.tar.gz`, where `XXXX` is a version number, to a file system that the host can recognize and perform the remaining steps in this procedure.

---

3. Create the temporary directory called `/temporary` that has more than 600 MB of available disk space on the file system and expand the compressed files. In the example below, `XXXX` denotes a version number.

```
mkdir /temporary
cd /temporary
gunzip < /cdrom/HSNM2-XXXX-S-GUI.tar.gz | tar xf -
```

4. In the console, issue the following command.

```
/temporary/install-hsnm2.sh -a [IP address] -p [port number]
```

Specify the IP address (or host name) and port number used to access Navigator 2. If you use 1099 for the port number, you can omit the `-p` option. Do not specify 127.0.0.1 and localhost. Otherwise, the Navigator 2 Applet window is not displayed. In DHCP environments, specify host name (computer name) in the [*IP address*] field.

5. Delete the temporary directory

## Upgrading Navigator 2 on Linux operating systems

To upgrade Navigator 2 on a Navigator 2-supported Linux operating system, use the following procedure.

1. If the host is running applications other than Navigator 2 that use Hitachi Storage Command Suite Common Components on the host, stop the daemon process of the Hitachi Storage Command Suite Common Components.
2. Insert the Navigator 2 installation CD-ROM in the computer's CD/DVD-ROM drive.



---

**NOTE:** If the host cannot read the CD-ROM, copy the files `install-hsnm2.sh` and `HSNM2-XXXX-L-GUI.rpm`, where `XXXX` is a version number, to a file system that the host can recognize and perform the remaining steps in this procedure.

---

3. Mount the CD-ROM on the file system. The mount destination is `/cdrom`.
4. In the console, issue the following command:

```
sh /cdrom/install-hsnm2.sh
```

Do not specify 127.0.0.1 and localhost. Otherwise, the Navigator 2 Applet window will not appear. In DHCP environments, specify the host name (computer name) to the IP Addr. field.



## Uninstalling Navigator 2

This appendix describes how to uninstall the Navigator 2 software on a host running one of the Navigator 2-supported operating systems.

The topics covered in this appendix are:

- [Before you start](#)
- [Windows operating systems](#)
- [Solaris and Linux operating systems](#)

## Before you start

Observe the following guidelines before uninstalling Navigator 2.

- If the host is running applications other than Navigator 2 that use Hitachi Storage Command Suite Common Components, back up the database for those applications before uninstalling Navigator 2.
- If the message **forcible uninstallation is necessary** appears when uninstalling Navigator 2, restart the computer and uninstall Navigator 2 again. If you still cannot uninstall Navigator 2, reinstall the operating system.

## Windows operating systems

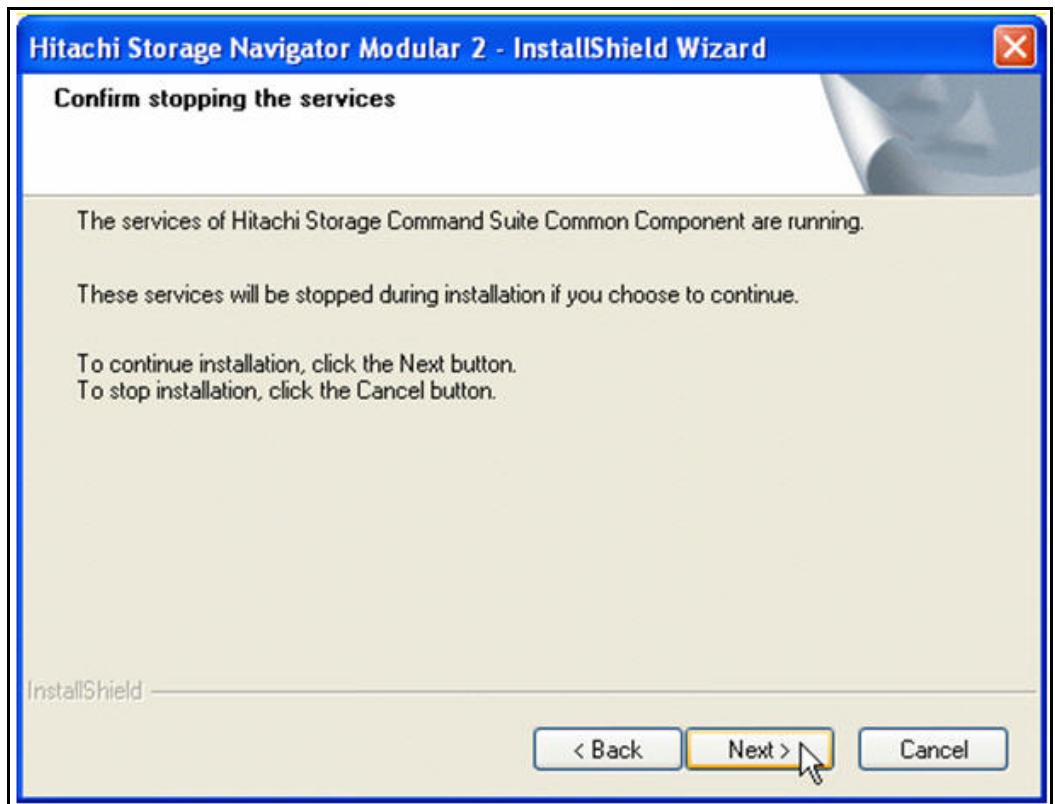
To uninstall Navigator 2 on a Navigator 2-supported Windows operating system, use the following procedure.

1. Click the Windows **Start** button and choose **Settings, Control Panel,** and **Add or Remove Programs**.
2. In the Add or Remove Programs panel, click **Hitachi Storage Navigator Modular 2** from the **Currently installed programs** list.
3. Click **Remove**. The Uninstall Hitachi Storage Navigator Modular 2 window appears (see [Figure B-1](#)).



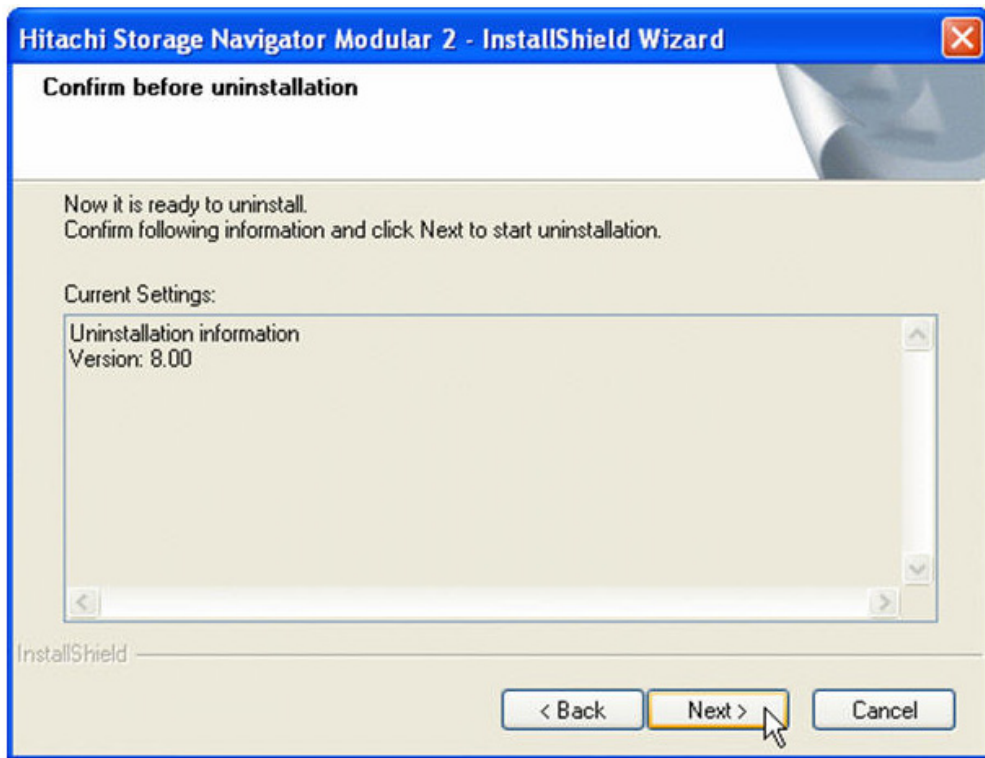
**Figure B-1: Uninstall Hitachi Storage Navigator Modular 2 Window**

4. Click **Next**. The Confirm stopping the services window appears (see [Figure B-2 on page B-3](#)).



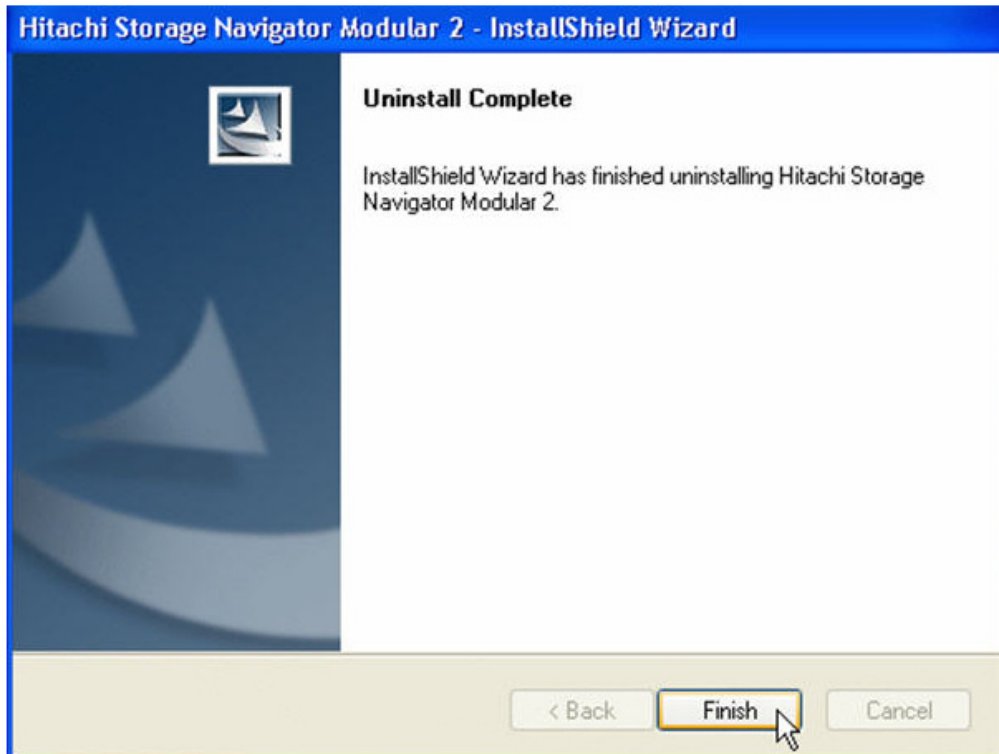
**Figure B-2: Confirm stopping the services Window**

5. Click **Next**. The Confirm before uninstallation window appears (see [Figure B-3 on page B-4](#)).



**Figure B-3: Confirm before uninstallation Window**

6. Click **Next**. When un-installation is complete, the Uninstall Complete window appears (see [Figure B-4](#)).



**Figure B-4: Uninstall Complete Window**

7. Click **Finish**.
8. If other applications using Hitachi Storage Command Suite Common Components have been installed, restart the services (for more information, refer to the manual for each application).

## Solaris and Linux operating systems

To uninstall Navigator 2 on a Navigator 2-supported Solaris or Linux operating system, use the following procedure.

1. If the host is running applications other than Navigator 2 that use Hitachi Storage Command Suite Common Components on the host, stop the daemon process of the Hitachi Storage Command Suite Common Components.
2. In the console, issue the following command line:

```
/opt/HiCommand/StorageNavigatorModular/uninstall-hsnm2.sh
```





## Recording Navigator 2 Settings

This appendix provides a form for you to record the configuration settings that you created for your Hitachi storage system. Hitachi recommends that you make a copy of the following table and record your Navigator 2 configuration settings for future reference. [Table C-1](#) provides a form for you to record your settings.

**Table C-1: Recording Configuration Settings**

Field	Description
Storage System Name	
Management console static IP address (used to log in to Navigator 2)	
<b>Email Notifications</b>	
Email Notifications	<input type="checkbox"/> Disabled <input type="checkbox"/> Enabled (record your settings below)
Domain Name	
Mail Server Address	
From Address	
Send to Address Address 1: Address 2: Address 3:	
Reply To Address	
<b>Management Port Settings</b>	
Controller 0	
Configuration	<input type="checkbox"/> Automatic (Use DHCP) <input type="checkbox"/> Manual (record your settings below)
IP Address	
Subnet Mask	
Default Gateway	
Controller 1	
Configuration	<input type="checkbox"/> Automatic (Use DHCP) <input type="checkbox"/> Manual (record your settings below)
IP Address	
Subnet Mask	
Default Gateway	
<b>Data Port Settings</b>	
Controller 0/ Port A	
IP Address	
Subnet Mask	
Default Gateway	
Negotiation	
Controller 0/ Port B	
IP Address	
Subnet Mask	

**Table C-1: Recording Configuration Settings (Continued)**

<b>Field</b>	<b>Description</b>
Default Gateway	
Negotiation	
Controller 1/ Port A	
IP Address	
Subnet Mask	
Default Gateway	
Negotiation	
Controller 1/ Port B	
IP Address	
Subnet Mask	
Default Gateway	
Negotiation	
<b>LUN Settings</b>	
RAID Group	
Free Space	
LUN	
Capacity	
Stripe Size	
Format the Logical Unit	<input type="checkbox"/> Yes <input type="checkbox"/> No





# Understanding IP addresses

Every machine on the Internet has a unique identifying number, called an IP address. Computers interpret IP addresses as binary values of 0 and 1. To make this value easier for humans to understand, this binary value is expressed in decimal format as a “dotted decimal number”. For example, 192.168.0.17 is an example of an IP address.

This chapter provides a brief background about IP addresses. It covers the following key topics:

- ❑ [Working with IP address settings](#)
- ❑ [Viewing your PC’s IP address settings](#)
- ❑ [Changing your PC’s IP address settings](#)
- ❑ [Internet Protocol version 6](#)

## Working with IP address settings

An IP address is the unique address for each device connected to the Internet, such as your computer or Simple Modular Storage array. An IP address consists of four numeric segments called "octets" that are separated by periods (for example, 192.168.0.100).

As you learned from installing Storage Navigator Modular 2 (Navigator 2), IP addresses can be static, in which case a permanent number is assigned to your computer (by your network or administrator), or they can be dynamic, meaning a temporary number is assigned each time you connect to the network.

## Viewing your PC's IP address settings

The Navigator 2 installation required you to ascertain the IP address of your PC. The manual or online help for your operating system should describe how to view your PC's IP address. With Windows XP or 2000, for example, you can perform the following steps to see what IP address, default gateway, and subnet mask your PC is using:

1. Click the Start button and select **All Programs** (Windows XP) or **Programs** (Windows 2000).
2. Select **Accessories**, then **Command Prompt**.
3. At the command prompt, type **ipconfig** and press the Enter key. Your PC's IP address, subnet mask, and default gateway are displayed (see [Figure D-1](#)).
4. To close the command prompt, type **exit** and press Enter.

```
C:\Documents and Settings>ipconfig

Windows IP Configuration

Ethernet adapter Local Area Connection:

    Connection-specific DNS Suffix  . : 
    IP Address . . . . . : 192.168.1.25
    Subnet Mask . . . . . : 255.255.255.0
    Default Gateway . . . . . : 192.168.1.1
```

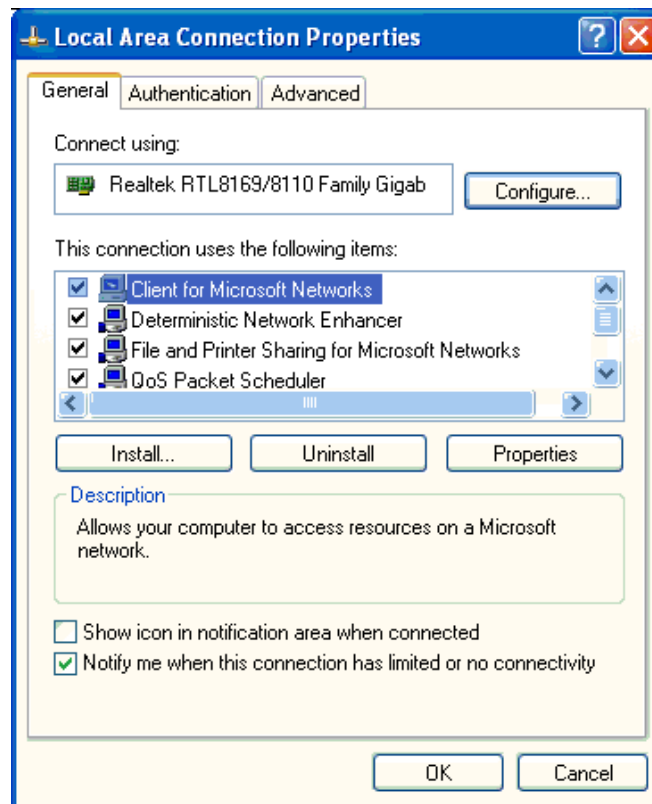
**Figure D-1: Example of Using ipconfig**

If your PC has Internet access, you can also visit [www.ShowIPAddress.com](http://www.ShowIPAddress.com). The site will display your IP address and other information about your system.

## Changing your PC's IP address settings

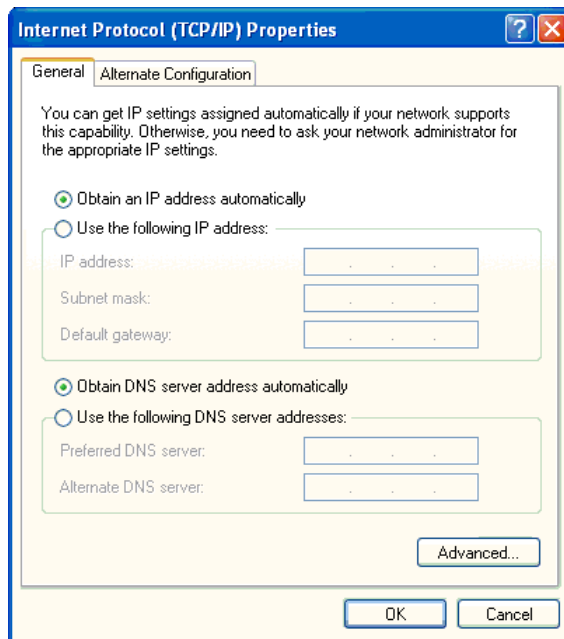
To change your PC's IP address in Windows XP and Windows 2000:

1. Click on the Start button and select **Control Panel**.
2. Click on **Network and Internet connections**.
3. In the Control Panel window, double-click on **Network Connections**. Icons for each Local Area connection are displayed.
4. Either double-click a **Local Area Connection** or right click a **Local Area Connection** and select **Properties**. The Local Area Connection Properties dialog box window appears (see [Figure D-2](#)).



**Figure D-2: Local Area Connection Properties Dialog Box**

5. Under **This connection uses the following items**, scroll down until you see **Internet Protocol (TCP/IP)**. Then select this connection type and click **Properties**. The Internet Protocol (TCP/IP) Properties dialog box appears (see [Figure D-3 on page D-4](#)).



**Figure D-3: Sample Internet Protocol (TCP/IP) Properties Dialog Box**

6. Click **Use the following IP address**. The **IP address**, **Subnet mask**, and **Default gateway** fields become available.
7. Enter the required IP address, subnet, and gateway in the appropriate fields.
8. Click the **OK** button to return to the Local Area Connection Properties dialog box.
9. Click the **OK** button to exit the Local Area Connection Properties dialog box.

## Internet Protocol version 6

Most of today's Internet uses Internet Protocol version 4 (IPv4). However, with the popularity of IP-enabled devices that access Internet and packet-switched internetworks, there is an increasing shortage of IPv4 addresses. As the next-generation Internet protocol, IPv6 fixes the problem of dealing with a limited number of available IPv4 addresses.

### IPv6 guidelines

Some Navigator 2 screens allow you to enter IPv6 addresses, as well as IPv4 addresses. This section provides guidelines when using IPv6 addresses with Navigator 2.

## Hitachi Storage Navigator Modular 2 graphical interface

Table D-1 lists the Pv6 support conditions for the Hitachi Storage Navigator Modular 2 (Navigator 2) graphical interface.

**Table D-1: Microsoft Operating Systems That Support IPv6**

Operating System	System Pack	IPv6 Support
Windows 2000	Service Pack 3/ Service Pack 4	Not supported
Windows XP	Service Pack 2	Although the IPv6 protocol can be used by installing Microsoft TCP/IP version6, Navigator 2 does not support it because the Web browser cannot use the IPv6 literal address in colon-delimited hexadecimal notation.
Windows Server 2003 (x86)	Service Pack 1	Supported
Windows Server 2003 (x86)	Service Pack 2	Supported
Windows Server 2003 R2 (x86)	Service Pack 1	Supported
Windows Server 2003 R2 (x64)	Service Pack 1	Supported
Windows Vista (x86)	Service Pack 1	Supported
Windows Server 2008 (x86)	Service Pack 1	Supported
Windows Server 2008 (x64)	Service Pack 1	Supported

### IPv6 link-local addresses

Based on RFC 2462, all IPv6 nodes automatically configure a link-local address for each interface. By default, the IPv6 protocol for the supported Microsoft Windows operating systems in [Table D-1 on page D-5](#) configure link-local addresses for each interface that corresponds to an installed Ethernet network interface card (NIC). Link-local addresses have the prefix FE80::/64. The last 64 bits of the IPv6 address is referred to as the interface identifier. It is derived from the 48-bit Media Access Channel (MAC) address of the NIC.

To create the IPv6 interface identifier from the 48-bit (6-byte) Ethernet MAC address:

- The hexadecimal digits 0xFF-FE are inserted between the third and fourth bytes of the MAC address.
- The Universal/Local bit (the second low-order bit of the first byte of the MAC address) is complemented. If it is a 1, it is set to 0; if it is a 0, it is set to 1.

For example, for the MAC address of 00-60-08-52-F9-D8:

- The hexadecimal digits 0xFF-FE are inserted between 0x08 (the third byte) and 0x52 (the fourth byte) of the MAC address, forming the 64-bit address of 00-60-08-FF-FE-52-F9-D8.
- The Universal/Local bit, the second low-order bit of 0x00 (the first byte) of the MAC address, is complemented. The second low-order bit of 0x00 is 0 which, when complemented, becomes 1. The result is that for the first byte, 0x00 becomes 0x02.

As a result, the IPv6 interface identifier that corresponds to the Ethernet MAC address of 00-60-08-52-F9-D8 is 02-60-08-FF-FE-52-F9-D8.



**NOTE:** If you use IPv6 addresses with your array, we recommend you set IP addresses manually on the Navigator 2 Set up Management Ports screen. If you select **Use DHCP** in the Navigator 2 Set up Management Port screen, the IPv6 address changes if you replace arrays, since the IPv6 address is created based on the array's MAC address. This will require you to perform the Navigator 2 search array and registration.



**TIP:** For the range of the IPv6 address set manually, use the global unicast address 2001::/16.

The link-local address of a node is the combination of the prefix FE80::/64 and the 64-bit interface identifier expressed in colon-hexadecimal notation. As a result, the link-local address of this example node, with the prefix FE80::/64 and the interface identifier 02-60-08-FF-FE-52-F9-D8, is FE80::260:8FF:FE52:F9D8.

You can view your link local address using the **netsh interface ipv6 show interface** command. When you run this command without any additional parameters, a list similar to the following is displayed:

Idx	Met	MTU	State	Name
5	0	1500	Connected	Local Area Connection
4	0	1500	Connected	Local Area Connection 2
3	1	1280	Connected	6to4 Tunneling Pseudo-Interface
2	0	1280	Connected	Automatic Tunneling Pseudo-Interface
1	0	1500	Connected	Loopback Pseudo-Interface

For more detailed output, you can designate a connection name as a command parameter (for example, **netsh interface ipv6 show interface "Local Area Connection 2"**). Using the interface parameter (with either an interface name or an interface index number) results in the following output, which includes the link local address for the connection:

```

Interface 4: Local Area Connection 2

Addr Type   DAD State   Valid Life   Pref. Life   Address
-----
Temporary Preferred 6d4h41m33s   4h38m46s   3ffe:2900:d005:f282:4063:32a8:5c81:62f2
Temporary Deprecated 5d4h44m24s   0s         3ffe:2900:d005:f282:cd74:3dd7:857b:b57
Temporary Deprecated 4d4h47m16s   0s         3ffe:2900:d005:f282:d880:d193:f2dd:d929
Temporary Deprecated 3d4h50m7s    0s         3ffe:2900:d005:f282:7482:2f05:8129:54ba
Temporary Deprecated 2d4h52m59s   0s         3ffe:2900:d005:f282:d530:25de:57b:7ee0
Temporary Deprecated 1d4h55m50s   0s         3ffe:2900:d005:f282:c58c:4290:22c6:7b3b
Temporary Deprecated 4h58m42s     0s         3ffe:2900:d005:f282:8464:acf0:8393:cf6
Public Preferred 29d23h57m19s 6d23h57m19s fec0::f282:2c0:4fff:fe19:bad3
Public Preferred 29d23h57m19s 6d23h57m19s 3ffe:2900:d005:f282:2c0:4fff:fe19:bad3
Link Preferred infinite infinite fe80::2c0:4fff:fe19:bad3

Connection Name      : Local Area Connection 2
GUID                 : {433F15CA-E3FD-4DE4-B3FF-7EF4B30CA4E7}
State                : Connected
Metric               : 0
Link MTU              : 1500 bytes
True Link MTU        : 1500 bytes
Current Hop Limit    : 64
Reachable Time       : 4h43m20s
Base Reachable Time  : 8h20m
Retransmission Interval : 16m40s
DAD Transmits        : 1
DNS Suffix            : example.microsoft.com
Zone ID for Link     : 4
Zone ID for Site     : 1
Uses Neighbor Discovery : Yes
Sends RA's           : No
Forwards Packets     : No
Link-Layer Address   : 00-c0-4f-19-ba-d3

```

In this example, Interface 4 is an interface that corresponds to an installed Ethernet adapter with a link-local address of FE80::2C0:4FFF:FE19:BAD3.

## Router discovery

IPv6 solves many problems related to the interaction between nodes that are attached to the same link. To accomplish this, an IPv6 host “advertises” its presence, various link parameters, and various Internet parameters using router discovery — an exchange of Router Solicitation and Router Advertisement messages — to ascertain additional addresses and configuration settings.

To accomplish this, routers “advertise” their presence, various link parameters, and various Internet parameters. Routers advertise either periodically, or in response to a router solicitation message. Router advertisements contain prefixes that are used for on-link determination or address configuration, a suggested hop limit value, and other purposes.

If you need to change the contents of a router advertisement for a host attached to the array, use the command **set Router Lifetime** and specify an expiration date of 0 to disable the previous router advertisement. Otherwise, you will have to perform the Navigator 2 search array and registration.

## Temporary addresses

Computers running Microsoft Windows Vista or Windows Server 2008 by default generate random interface IDs for non-temporary autoconfigured IPv6 addresses, including public and link-local addresses, instead of EUI-64-

based interface IDs. As a public IPv6 address is a global address that is registered in DNS and is typically used by server applications for incoming connections, such as a Web server.

This default setting can cause many temporary addresses to be registered in the host, increasing processing times. Therefore, we recommend you check the temporary addresses and, if there are many, disable them.

To check whether a temporary addresses is enabled or disabled, type the following command from the command prompt.

```
C:\> netsh interface ipv6 show privacy
```

To disable temporary addresses, type the following command:

```
C:\> netsh interface ipv6 set privacy disable
```

Type the following command to return them to Enabled.

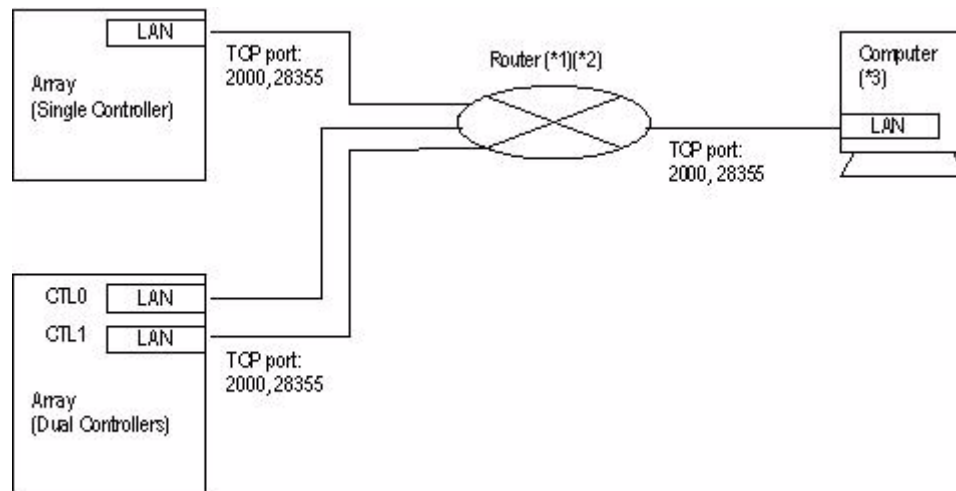
```
C:\> netsh interface ipv6 set privacy enable
```

## Connection methods

The following examples show connections between the array and the computer in which Navigator 2 has been installed.

### Example 1

Figure D-4 shows a configuration where a computer with Navigator 2 and the computer have the same IPv6 addresses.



**Figure D-4: Sample Configuration 1**

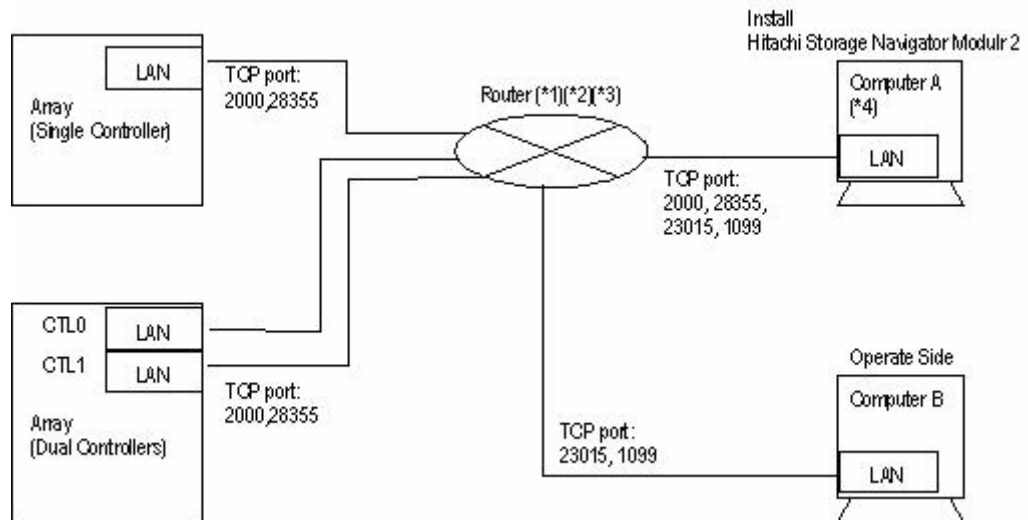
In this configuration:

- The array uses 2000/tcp and 28355/tcp to communicate with Navigator 2. If the array is connected directly to a computer, but cannot communicate through the router, the router may have blocked ports. In this case, configure the router to permit 2-way communication to ports.

- IPv6 multicasting is used on the local link to search for the array's IPv6 address. Prior to having Navigator 2 search for the array, configure the array and the computer in which Navigator 2 is installed to reside on the same link.
- If the computer where Navigator 2 is installed has two or more NICs connected to separate network segments, Navigator 2 can only access the LAN whose addresses were specified when Navigator 2 was installed.

## Example 2

Figure D-5 shows a configuration where a computer with Navigator 2 and another computer are configured with different IPv6 addresses.



**Figure D-5: Sample Configuration 2**

In this configuration:

- The array uses 2000/tcp and 28355/tcp to communicate with Navigator 2. If the computer is connected directly to the array, but cannot communicate through the router, the router may have blocked ports. In this case, configure the router to permit 2-way communication to ports.
- The computer in which Navigator 2 is installed (Computer A) uses 23015/tcp and 1099/tcp to communicate with Computer B. If Computer A can be connected directly to the array, but cannot communicate through the router, the router may have blocked ports. In this case, configure the router to permit 2-way communication to ports.
- IPv6 multicasting is used on the local link to search for the array's IPv6 address. Prior to having Navigator 2 search for the array, configure the array and the computer in which Navigator 2 is installed to reside on the same link.
- If the computer where Navigator 2 is installed has two or more NICs connected to separate network segments, Navigator 2 can only access the LAN whose addresses were specified when Navigator 2 was installed.





# Glossary

This glossary provides definitions of general storage networking terms as well as specific terms related to the technology that supports Hitachi Data Systems products. Click the letter of the glossary section to display that page.

<a href="#">A</a>	<a href="#">B</a>	<a href="#">C</a>	<a href="#">D</a>	<a href="#">E</a>	<a href="#">F</a>	<a href="#">G</a>	<a href="#">H</a>	<a href="#">I</a>	<a href="#">J</a>	<a href="#">K</a>	<a href="#">L</a>	<a href="#">M</a>	<a href="#">N</a>	<a href="#">O</a>	<a href="#">P</a>	<a href="#">Q</a>	<a href="#">R</a>	<a href="#">S</a>	<a href="#">T</a>	<a href="#">U</a>	<a href="#">V</a>	<a href="#">W</a>	<a href="#">X</a>	<a href="#">Y</a>	<a href="#">Z</a>
-------------------	-------------------	-------------------	-------------------	-------------------	-------------------	-------------------	-------------------	-------------------	-------------------	-------------------	-------------------	-------------------	-------------------	-------------------	-------------------	-------------------	-------------------	-------------------	-------------------	-------------------	-------------------	-------------------	-------------------	-------------------	-------------------

## **1000BASE-T**

A specification for Gigabit Ethernet over copper wire. The standard defines 1 Gbps data transfer over distances of up to 100 meters using four pairs of Category 5 balanced copper cabling and a 5-level coding scheme.

## **Array**

A set of hard disks grouped logically together to function as one contiguous storage space.

## **ATA**

Advanced Technology Attachment, a disk drive implementation that integrates the controller on the disk drive.

## **BIOS**

Basic Input Output System, built-in software code that determines the functions that a computing device can perform without accessing programs from a disk.

## **Bps**

Bits per second, the standard measure of data transmission speeds.

## **BSD syslog protocol**

This protocol has been used for the transmission of event notification messages across networks for many years. While this protocol was originally developed on the University of California Berkeley Software Distribution (BSD) TCP/IP system implementations, its value to operations and management has led it to be ported to many other operating systems as well as being embedded into many other networked devices.

## **Cache**

A temporary, high-speed storage mechanism. It is a reserved section of main memory or an independent high-speed storage device. Two types of caching are found in computers: memory caching and disk caching. Memory caches are built into the architecture of microprocessors and often computers have external cache memory. Disk caching works like memory caching; however, it uses slower, conventional main memory that on some devices is called a memory buffer.

## **Capacity**

The amount of information (usually expressed in megabytes) that can be stored on a disk drive. It is the measure of the potential contents of a device; the volume it can contain or hold. In communications,

A	B	C	D	E	F	G	H	I	J	K	L	M	N	O	P	Q	R	S	T	U	V	W	X	Y	Z
---	---	---	---	---	---	---	---	---	---	---	---	---	---	---	---	---	---	---	---	---	---	---	---	---	---

## **Glossary–2**

capacity refers to the maximum possible data transfer rate of a communications channel under ideal conditions.

### **Challenge Handshake Authentication Protocol**

A security protocol that requires users to enter a secret for access.

### **CHAP**

See Challenge Handshake Authentication Protocol.

### **command control interface (CCI)**

Hitachi's Command Control Interface software provides command line control of Hitachi array and software operations through the use of commands issued from a system host. Hitachi's CCI also provides a scripting function for defining multiple operations.

### **command line interface (CLI)**

A method of interacting with an operating system or software using a command line interpreter. With Hitachi's Storage Navigator Modular Command Line Interface, CLI is used to interact with and manage Hitachi storage and replication systems.

### **DHCP**

Dynamic Host Configuration Protocol, allows a computer to join an IP-based network without having a pre-configured IP address. DHCP is a protocol that assigns unique IP addresses to devices, then releases and renews these addresses as devices leave and re-join the network.

### **Differential Management Logical Unit (DMLU)**

The volumes used to manage differential data in a storage system. In a TrueCopy Extended Distance system, there may be up to two DM logical units configured per storage system. For Copy-on-Write and ShadowImage, the DMLU is an exclusive volume used for storing data when the array system is powered down.

### **Duplex**

The transmission of data in either one or two directions. Duplex modes are full-duplex and half-duplex. Full-duplex is the simultaneous transmission of data in two direction. For example, a telephone is a full-duplex device, because both parties can talk at once. In contrast, a walkie-talkie is a half-duplex device because only one party can transmit at a time.

A	B	C	D	E	F	G	H	I	J	K	L	M	N	O	P	Q	R	S	T	U	V	W	X	Y	Z
---	---	---	---	---	---	---	---	---	---	---	---	---	---	---	---	---	---	---	---	---	---	---	---	---	---

**Fabric**

The hardware that connects workstations and servers to storage devices in a SAN. The SAN fabric enables any-server-to-any-storage device connectivity through the use of fibre channel switching technology.

**FC**

Fibre channel.

**Firmware**

Software embedded into a storage device. It may also be referred to as Microcode.

**Full-duplex**

The concurrent transmission and the reception of data on a single link.

**Gbps**

Gigabit per second.

**GUI**

Graphical user interface.

**HBA**

Host bus adapter, a circuit board and/or integrated circuit adapter installed in a workstation or server that provides input/output processing and physical connectivity between a server and a storage device. An iSCSI HBA implements the iSCSI and TCP/IP protocols in a combination of a software storage driver and hardware.

**HDD**

Hard disk drive.

**Initiator**

A system component that originates an I/O command over an I/O bus or network, such as an I/O adapters or network interface cards.

**I/O**

Input/output.

A	B	C	D	E	F	G	H	I	J	K	L	M	N	O	P	Q	R	S	T	U	V	W	X	Y	Z
---	---	---	---	---	---	---	---	---	---	---	---	---	---	---	---	---	---	---	---	---	---	---	---	---	---

## **IP**

Internet Protocol, specifies the format of packets and addressing scheme. Most networks combine IP with a higher-level protocol called Transmission Control Protocol (TCP), which establishes a virtual connection between a destination and a source.

## **IP address**

An identifier for a computer or device on a TCP/IP network. Networks using the TCP/IP protocol route messages based on the IP address of the destination. The format of an IP address is a 32-bit numeric address written as four numbers separated by periods. Each number can be zero to 255 (for example, 192.168.0.200).

## **IP-SAN**

Block-level Storage Area Networks over TCP/IP using the iSCSI protocol.

## **iSCSI**

Internet SCSI, an IP-based standard for connecting data storage devices over a network and transferring data using SCSI commands over IP networks. iSCSI enables a Storage Area Network to be deployed in a Local Area Network.

## **iSNS**

Internet Storage Name Service, a protocol that allows automated discovery, management and configuration of iSCSI devices on a TCP/IP network.

## **L**

### **LAN**

Local Area Network, a computer network that spans a relatively small area, such as a single building or group of buildings.

### **LU**

Logical unit.

### **LUN**

Logical unit number.

A	B	C	D	E	F	G	H	I	J	K	L	M	N	O	P	Q	R	S	T	U	V	W	X	Y	Z
---	---	---	---	---	---	---	---	---	---	---	---	---	---	---	---	---	---	---	---	---	---	---	---	---	---

## **Middleware**

Software that connects two otherwise separate applications. For example, a middleware product can be used to link a database system to a Web server. Using forms, users request data from the database; then, based on the user's requests and profile, the Web server returns dynamic Web pages to the user.

## **MIB**

Message Information Block.

## **NIC**

Network Interface Card, an expansion board in a computer that allows the computer to connect to a network.

## **NTP**

Network Time Protocol, a protocol for synchronizing the clocks of computer systems over packet-switched, variable-latency data networks. NTP uses UDP port 123 as its transport layer. It is designed particularly to resist the effects of variable latency (jitter).

## **Pool volume**

A pool volume is used to store backup versions of files, archive copies of files, and files migrated from other storage.

## **primary volume (P-VOL)**

The storage volume in a volume pair. It is used as the source of a copy operation. In copy operations a copy source volume is called the P-VOL while the copy destination volume is called S-VOL (secondary volume).

## **RAID**

Redundant Array of Independent Disks, a disk array in which part of the physical storage capacity is used to store redundant information about user data stored on the remainder of the storage capacity. The redundant information enables regeneration of user data in the event that one of the array's member disks or the access path to it fails. SNIA.

A	B	C	D	E	F	G	H	I	J	K	L	M	N	O	P	Q	R	S	T	U	V	W	X	Y	Z
---	---	---	---	---	---	---	---	---	---	---	---	---	---	---	---	---	---	---	---	---	---	---	---	---	---

## **RAID 6**

An extension of the RAID 5 array, that allows for two simultaneous drive failures without downtime or data loss. recovery point objective (RPO).

After a recovery operation, the recovery point objective (RPO) is the maximum desired time period, prior to a disaster, in which changes to data may be lost. This measure determines up to what point in time data should be recovered. Data changes preceding the disaster are preserved by recovery.

## **SAN**

Storage Area Network, a network of shared storage devices that contain disks for storing data.

## **SAS**

Serial Attached SCSI, an evolution of parallel SCSI into a point-to-point serial peripheral interface in which controllers are linked directly to disk drives. SAS delivers improved performance over traditional SCSI because SAS enables up to 128 devices of different sizes and types to be connected simultaneously.

## **SATA**

Serial ATA is a computer bus technology primarily designed for the transfer of data to and from hard disks and optical drives. SATA is the evolution of the legacy Advanced Technology Attachment (ATA) interface from a parallel bus to serial connection architecture.

## **SCSI**

Small Computer System Interface, a parallel interface standard that provides faster data transmission rates than standard serial and parallel ports.

## **Session**

A series of communications or exchanges of data between two end points that occurs during the span of a single connection. The session begins when the connection is established at both ends, and terminates when the connection is ended. For some applications each session is related to a particular port. In this document a session is the exchange of data between groups of primary and secondary volumes.

## **secondary volume (S-VOL)**

A replica of the primary volume (P-VOL) at the time of a backup and is kept on a standby storage system. Recurring differential data updates are performed to keep the data in the S-VOL consistent with data in the P-VOL.

A	B	C	D	E	F	G	H	I	J	K	L	M	N	O	P	Q	R	S	T	U	V	W	X	Y	Z
---	---	---	---	---	---	---	---	---	---	---	---	---	---	---	---	---	---	---	---	---	---	---	---	---	---

## **SMTP**

Simple Mail Transfer Protocol, a protocol used to receive and store email data directly from email servers.

## **Software initiator**

A software application initiator communicates with a target device. A software initiator does not require specialized hardware because all processing is done in software, using standard network adapters.

## **Storage Navigator Modular 2**

A multi-featured scalable storage management application that is used to configure and manage the storage functions of Hitachi arrays. Also referred to as Navigator 2.

## **Subnet**

In computer networks, a subnet or subnetwork is a range of logical addresses within the address space that is assigned to an organization. Subnetting is a hierarchical partitioning of the network address space of an organization (and of the network nodes of an autonomous system) into several subnets. Routers constitute borders between subnets. Communication to and from a subnet is mediated by one specific port of one specific router, at least momentarily. SNIA.

## **Switch**

A network infrastructure component to which multiple nodes attach. Unlike hubs, switches typically have internal bandwidth that is a multiple of link bandwidth, and the ability to rapidly switch node connections from one to another. A typical switch can accommodate several simultaneous full link bandwidth transmissions between different pairs of nodes. SNIA.

## **Target**

Devices that receive iSCSI requests that originate from an iSCSI initiator.

## **TOE**

A dedicated chip or adapter that handles much of the TCP/IP processing directly in hardware. TCP/IP transmission is inherently a CPU-intensive operation. Therefore, using dedicated hardware that can operate in parallel with the main processor allows for superior system performance. Although all iSCSI HBAs have a TOE, a generic TOE only implements TCP/IP, while an iSCSI HBA implements the iSCSI protocol in addition to TCP/IP.

A	B	C	D	E	F	G	H	I	J	K	L	M	N	O	P	Q	R	S	T	U	V	W	X	Y	Z
---	---	---	---	---	---	---	---	---	---	---	---	---	---	---	---	---	---	---	---	---	---	---	---	---	---

## User Datagram Protocol (UDP)

UDP is one of the core protocols of the Internet protocol suite. Using UDP, programs on networked computers can send short messages sometimes known as datagrams (using Datagram Sockets) to one another.

UDP does not guarantee reliability or ordering in the way that TCP does. Datagrams may arrive out of order, appear duplicated, or go missing without notice. Avoiding the overhead of checking whether every packet actually arrived makes UDP faster and more efficient, at least for applications that do not need guaranteed delivery. Time-sensitive applications often use UDP because dropped packets are preferable to delayed packets. UDP's stateless nature is also useful for servers that answer small queries from huge numbers of clients. Unlike TCP, UDP is compatible with packet broadcast (sending to all on local network) and multicasting (send to all subscribers).

## World Wide Name (WWN)

A unique identifier for an open systems host. It consists of a 64-bit physical address (the IEEE 48-bit format with a 12-bit extension and a 4-bit prefix). The WWN is essential for defining the SANTinel™ parameters because it determines whether the open systems host is to be allowed or denied access to a specified logical unit or a group of logical units.

A	B	C	D	E	F	G	H	I	J	K	L	M	N	O	P	Q	R	S	T	U	V	W	X	Y	Z
---	---	---	---	---	---	---	---	---	---	---	---	---	---	---	---	---	---	---	---	---	---	---	---	---	---

A	B	C	D	E	F	G	H	I	J	K	L	M	N	O	P	Q	R	S	T	U	V	W	X	Y	Z
---	---	---	---	---	---	---	---	---	---	---	---	---	---	---	---	---	---	---	---	---	---	---	---	---	---

**Glossary–10**

# Index

## A

- Activities in Navigator 2 [5-3](#)
- Add Array wizard [4-5](#)
- Adding
  - User IDs [6-8](#)
  - users [6-2](#)
- Alerts [7-13](#)
- Anti-virus software [2-9](#)
- Arrays window [7-2](#)

## B

- Backup Volume wizard [4-19](#)
- Button Panel [5-3](#)

## C

- Certificate and private key [10-8](#)
- Changing
  - default system password [6-6](#)
  - IP address for Navigator 2 [10-13](#)
  - LUN capacity [9-6](#)
  - passwords for Password Protection [6-8](#)
  - permission [6-5](#)
  - port number for Navigator 2 [10-14](#)
  - RAID group expansion priority [8-13](#)
  - user IDs [6-8](#)
  - user passwords [6-6](#)
- Configuring
  - email alerts [4-8](#)
  - email notifications [7-11](#)
  - error monitoring options [7-10](#)
  - host ports [4-10](#)
  - management ports [4-9](#)
  - spare drives [4-13](#)
  - system date and time [4-13](#)
- Connecting
  - management console [4-2](#)
  - to a host [4-18](#)
- Create & Map Volume wizard [4-14](#)
  - connecting to a host [4-18](#)
  - defining host groups or iSCSI targets [4-17](#)

- defining logical units [4-16](#)
- defining RAID groups [4-14](#)

- Creating
  - RAID groups [8-3](#)
- Creating a logical unit [9-4](#)

## D

- Default system password, changing [6-6](#)
- Defining
  - host groups or iSCSI targets [4-17](#)
  - Logical units [4-16](#)
  - RAID groups [4-14](#)
- Deleting
  - logical units [9-13](#)
  - RAID groups [8-13, 8-15, 9-11, 9-12, 9-13](#)
  - User IDs [6-9](#)
  - users [6-3](#)
- Destination folder selection [2-10](#)
- Detailed RAID group properties [8-9](#)
- Displaying detailed properties of RAID groups [8-9](#)
- Displaying logical unit properties [9-11](#)
- Downloading Java Runtime [2-7](#)

## E

- Editing
  - storage system settings [7-5](#)
  - user profiles [6-3](#)
- Email alerts [4-8](#)
- Error messages for error monitoring [7-12](#)
- Error monitoring [7-8](#)
  - configuring [7-10](#)
  - email notifications [7-11](#)
  - error messages [7-12](#)
  - running [7-11](#)
- Events [7-13](#)
- Executing a RAID group spin-up [8-12](#)
- Expanding RAID groups [8-5, 8-7, 8-8](#)
- Explorer Panel [5-2](#)

## F

- Failed installation on Windows [3-8](#), [11-2](#)
- Filtering
  - logical units [9-12](#)
- Filtering RAID groups [8-14](#), [9-12](#)
- Firewalls [2-9](#)
- Formatting logical units [9-11](#)

## G

- Granting permissions [6-5](#)

## H

- Hardware considerations [4-2](#)
- HiCommand Device Manager and Navigator 2 [10-22](#)
- Hitachi Storage Command Suite Common Components, preinstallation considerations [2-14](#)
- Host
  - connecting to in Create & Map Volume wizard [4-18](#)
- Host groups, defining [4-17](#)
- Host port configuration [4-10](#)

## I

- Identifying logical units [9-2](#)
- Initial (Array) Setup wizard [4-7](#)
  - email alert configuration [4-8](#)
  - host port configuration [4-10](#)
  - management port configuration [4-9](#)
  - spare drive configuration [4-13](#)
  - system date and time configuration [4-13](#)
- Installation
  - checklist [2-3](#)
  - types [3-2](#)
- Installation checklist [2-3](#)
- Installation fails on Windows [3-8](#), [11-2](#)
- Installation prerequisites
  - Linux kernel parameters [2-11](#)
  - Microsoft Windows [2-10](#)
  - Solaris [2-11](#)
  - Solaris v10 kernel parameters [2-13](#)
  - Solaris v8 and v9 kernel parameters [2-12](#)
- Installing
  - Java Runtime [2-7](#)
  - Navigator 2 [3-2](#)
- Interface of Navigator 2 [5-2](#)
- Internet Protocol version 6 [10-2](#), [D-4](#)
  - guidelines [10-2](#), [D-4](#)
  - link-local addresses [10-2](#), [D-5](#)
  - router discovery [10-4](#), [D-7](#)
  - supported operating systems [10-2](#)
  - temporary addresses [10-5](#), [D-7](#)
- IP address, changing for Navigator 2 [10-13](#)
- iSCSI targets, defining [4-17](#)
- Items supplied by user [2-7](#)

## J

- Java Runtime
  - downloading [2-7](#)
  - installing [2-7](#)

## K

- Kernel parameters
  - Linux [2-11](#)
  - Solaris v10 [2-13](#)
  - Solaris v8 and v9 [2-12](#)

## L

- License keys [2-10](#)
- Link-local addresses [10-2](#), [D-5](#)
- Linux
  - installation prerequisites [2-11](#)
  - kernel parameters [2-11](#)
  - Navigator 2 installation [3-11](#)
  - preinstallation considerations [2-9](#)
  - uninstalling Navigator 2 [B-5](#)
  - upgrading Navigator 2 [A-8](#)
- Logging in to Navigator 2 [4-2](#)
- Logical units
  - changing LUN capacity [9-6](#)
  - creating [9-4](#)
  - defining [4-16](#)
  - deleting [9-13](#)
  - filtering [9-12](#)
  - formatting [9-11](#)
  - identifying [9-2](#)
  - preconfigured [9-2](#)
  - properties [9-11](#)
  - types [9-2](#)

## M

- Management console
  - connecting to storage system [4-2](#)
- Management port configuration [4-9](#)
- Menu Panel [5-2](#)
- Microsoft Windows
  - installation prerequisites [2-10](#)
  - Navigator 2 installation [3-3](#)
  - Navigator 2 installation fails [3-8](#), [11-2](#)
  - preinstallation considerations [2-7](#)
  - selecting a destination folder [2-10](#)
  - uninstalling Navigator 2 [B-2](#)
  - upgrading Navigator 2 [A-5](#)

## N

- Navigator 2
  - activities [5-3](#)
  - changing IP address [10-13](#)
  - changing port number [10-14](#)
  - hardware considerations [4-2](#)
  - logging in [4-2](#)
  - operating environment [2-3](#)
  - operating systems that support IPv6 [7-11](#)

- Quick-Start Checklist [2-3](#)
- recording setting [C-1](#)
- terms [2-2](#)
- understanding the interface [5-2](#)
- uninstalling [B-1](#)
- upgrading [A-1](#)
- Navigator 2 installation [3-2](#)
  - checklist [2-3](#)
  - fails on Microsoft Windows [3-8, 11-2](#)
  - Linux [3-11](#)
  - Linux prerequisites [2-11](#)
  - Microsoft Windows [3-3](#)
  - Microsoft Windows prerequisites [2-10](#)
  - selecting a destination folder [2-10](#)
  - Solaris [3-10](#)
  - Solaris prerequisites [2-11](#)
  - types of [3-2](#)
- Navigator 2 interface
  - Button Panel [5-3](#)
  - Explorer Panel [5-2](#)
  - Menu Panel [5-2](#)
  - Page Panel [5-3](#)
- Navigator 2 settings, recording [C-1](#)

**O**

- Operating environment [2-3](#)
- Operating systems for IPv6 [10-2](#)

**P**

- Page Panel [5-3](#)
- Password Protection [6-7](#)
  - accessing [6-7](#)
  - changing passwords [6-8](#)
- Passwords [6-6](#)
  - changing default system [6-6](#)
  - changing user [6-6](#)
- Permissions [6-4](#)
  - editing [6-5](#)
  - granting [6-5](#)
- Port number, changing for Navigator 2 [10-14](#)
- Preconfigured
  - logical units [9-2](#)
  - LUN on AMS 2000 storage systems [9-2](#)
- Preinstallation
  - anti-virus software [2-9](#)
  - checklist [2-3](#)
  - destination folder [2-10](#)
  - firewalls [2-9](#)
  - Java Runtime [2-7](#)
  - license keys [2-10](#)
  - Linux [2-9](#)
  - Microsoft Windows [2-7](#)
  - Solaris [2-9](#)
  - technical guidelines [2-10](#)
  - user-supplied items [2-7](#)
  - Windows operating systems [2-10](#)
- Prerequisites
  - Linux [2-11](#)
  - Solaris [2-11](#)

- Windows [2-10](#)
- Properties
  - logical units [9-11](#)
- Properties of RAID groups [8-9](#)

## Q

- Quick-Start Checklist [2-3](#)

## R

- RAID groups
  - changing expansion priority [8-13](#)
  - creating [8-3](#)
  - defining [4-14](#)
  - deleting [8-13, 8-15, 9-11, 9-12, 9-13](#)
  - detailed properties [8-9](#)
  - expanding [8-5, 8-7, 8-8](#)
  - filtering [8-14, 9-12](#)
  - properties [8-9](#)
  - removing expansion [8-8](#)
  - spin-up [8-12](#)
- Rebooting storage systems [7-3](#)
- Recording Navigator 2 settings [C-1](#)
- Removing
  - RAID group expansion [8-8](#)
  - storage systems [7-8](#)
- Router discovery with Internet Protocol version 6 [10-4, D-7](#)
- Running error monitoring [7-11](#)

## S

- SATA write and compare [10-22](#)
- Secure Sockets Layer [10-7](#)
  - certificate and private key [10-8](#)
- Selecting a destination folder [2-10](#)
- Showing and configuring storage systems [7-4](#)
- Solaris
  - installation prerequisites [2-11](#)
  - Navigator 2 installation [3-10](#)
  - preinstallation considerations [2-9](#)
  - uninstalling Navigator 2 [B-5](#)
  - upgrading Navigator 2 [A-7](#)
  - v10 kernel parameters [2-13](#)
  - v8 and v9 kernel parameters [2-12](#)
- Spare drive configuration [4-13](#)
- Storage systems
  - editing settings [7-5](#)
  - rebooting [7-3](#)
  - removing [7-8](#)
  - showing and configuring [7-4](#)
- System date and time configuration [4-13](#)
- System password, changing [6-6](#)

## T

- Technical guidelines [2-10](#)
- Temporary addresses with Internet Protocol version 6 [10-5, D-7](#)
- Terms associated with Navigator 2 [2-2](#)
- Trace information [11-3](#)

- Troubleshooting
  - alerts and events [7-13](#)
  - error monitoring [7-8](#)
  - installation fails on Microsoft Windows system [3-8](#), [11-2](#)
  - installation fails on Windows [3-8](#), [11-2](#)
- Types of installation [3-2](#)
- Types of logical units [9-2](#)

## U

- Understanding the Navigator 2 interface [5-2](#)
- Uninstalling Navigator 2 [B-1](#)
  - Linux [B-5](#)
  - Microsoft Windows [B-2](#)
  - Solaris [B-5](#)
- Upgrading Navigator 2 [A-1](#)
  - Linux [A-8](#)
  - Microsoft Windows [A-5](#)
  - Solaris [A-7](#)
- User account settings for HiCommand Device Manager and Navigator 2 [10-22](#)
- User IDs [6-8](#)
  - adding [6-8](#)
  - changing [6-8](#)
  - deleting [6-9](#)
- User passwords, changing [6-6](#)
- User profiles
  - editing [6-3](#)
  - viewing [6-3](#)
- Users [6-2](#)
  - adding [6-2](#)
  - deleting [6-3](#)
- User-supplied items [2-7](#)

## V

- Viewing
  - user profiles [6-3](#)

## W

- Wizards
  - Add Array [4-5](#)
  - Backup Volume [4-19](#)
  - Create & Map Volume [4-14](#)
  - Initial (Array) Setup [4-7](#)



### **Hitachi Data Systems**

Corporate Headquarters  
750 Central Expressway  
Santa Clara, California 95050-2627  
U.S.A.  
Phone: 1 408 970 1000  
[www.hds.com](http://www.hds.com)  
[info@hds.com](mailto:info@hds.com)

### **Asia Pacific and Americas**

750 Central Expressway  
Santa Clara, California 95050-2627  
U.S.A.  
Phone: 1 408 970 1000  
[info@hds.com](mailto:info@hds.com)

### **Europe Headquarters**

Sefton Park  
Stoke Poges  
Buckinghamshire SL2 4HD  
United Kingdom  
Phone: + 44 (0)1753 618000  
[info.eu@hds.com](mailto:info.eu@hds.com)



MK-99DF8208-01